



**Schneider**  
Electric

**SIEMENS**

**LS** ELECTRIC

**HYUNDAI**

**IS35**  
Ideal Selection Best Solution

**CHINT**

**Autonics**  
Sensors & Controllers

**SHIVA** **Amvaj**



آدرس : تهران ، خیابان لاله زار نو، بالاتر از خیابان منوچهری، مجتمع تجاری البرز ۲۰ ، طبقه اول ، واحد ۲۳۵  
تلفن : ۹۲ - ۰۲۱-۶۶۳۴۱۰۹۰      فروشگاه اینترنتی : [www.peoe.ir](http://www.peoe.ir)

@peoe\_iran

peoe\_iran

- SV-iS7 is the official name for the iS7 series inverters.
- This operation manual is intended for users with basic knowledge of electricity and electric devices.
- Keep this manual near the product for future reference whenever setting change, maintenance or service is required.
- Ensure that the field operators and service engineers can easily access this manual.
- For detailed information about the optional extension boards, including the specifications and the requirements for installation and operation, refer to the instruction manuals that are supplied with the products.

# Safety Information

Read and follow all safety instructions in this manual precisely to avoid unsafe operating conditions, property damage, personal injury, or death.

## Safety symbols in this manual

### Danger

Indicates an imminently hazardous situation which, if not avoided, will result in severe injury or death.

### Warning

Indicates a potentially hazardous situation which, if not avoided, could result in injury or death.

### Caution

Indicates a potentially hazardous situation which, if not avoided, could result in minor injury or property damage.

## Safety information

### Danger

- Do not open the cover of the equipment while it is on or operating. Likewise, do not operate the inverter while the cover is open. Exposure of the high voltage terminals or the charging area to the external environment may result in an electric shock. Do not remove any covers or touch the internal circuit boards (PCBs) or electrical contacts on the product when the power is on or during operation. Doing so may result in serious injury, death, or serious property damage.
- Do not open the cover of the equipment, even when the power supply to the inverter has been turned off, unless it is necessary for maintenance or regular inspection. Opening the cover may result in an electric shock even when the power supply is off.
- The equipment may hold a charge long after the power supply has been turned off. Use a multi-meter to make sure that the remaining voltage is below 30 VDC before working on the inverter, motor, or motor cable.

### Warning

- This equipment must be grounded for safe and proper operation.
- Do not supply power to a faulty inverter. If you find that the inverter is faulty, disconnect the power supply and have the inverter professionally repaired.
- The inverter becomes hot during operation. Avoid touching the inverter until it has cooled to avoid burns.
- Do not allow foreign objects, such as screws, metal chips, debris, water, or oil, to get inside the inverter. Allowing foreign objects inside the inverter may cause the inverter to malfunction or result in a fire.
- Do not operate the inverter with wet hands. Doing so may result in electric shock.

### Caution

- Do not modify the interior workings of the inverter. Doing so will void the warranty.
- Do not use cables with damages or cracks on the protective insulation when wiring the inverter. Damaged insulation may cause misoperation, an electric shock or a fire.
- Do not place heavy objects on top of electric cables. Doing so may damage the cable and result in an electric shock.



### Note

[English]

The maximum allowed prospective short-circuit current at the input power connection is defined in IEC 60439-1 as 100 kA. The drive is suitable for use in a circuit capable of delivering not more than 100 kA RMS at the drive's maximum rated voltage, depending on the selected MCCB. RMS symmetrical amperes for recommended MCCB are the following table.

[French]

Le courant maximum de court-circuit présumé autorisé au connecteur d'alimentation électrique est défini dans la norme IEC 60439-1 comme égal à 100 kA. L'entraînement convient pour une utilisation dans un circuit capable de délivrer pas plus de 100 kA RMS à la tension nominale maximale de l'entraînement. Le tableau suivant indique le MCCB recommandé selon le courant RMS symétrique en ampères.

|                 |                 |                   |                   |                   |         |         |
|-----------------|-----------------|-------------------|-------------------|-------------------|---------|---------|
| Working Voltage | UTE100<br>(E/N) | UTS150<br>(N/H/L) | UTS250<br>(N/H/L) | UTS400<br>(N/H/L) |         |         |
| 240V(50/60Hz)   | 50/65kA         | 65/100/150kA      | 65/100/150kA      | 65/100/150kA      |         |         |
| 480V(50/60Hz)   | 25/35kA         | 35/65/100kA       | 35/65/100kA       | 35/65/100kA       |         |         |
| Working Voltage | ABS33c          | ABS53c            | ABS63c            | ABS103c           | ABS203c | ABS403c |
| 240V(50/60Hz)   | 30kA            | 35kA              | 35kA              | 85kA              | 85kA    | 75kA    |
| 480V(50/60Hz)   | 7.5kA           | 10kA              | 10kA              | 26kA              | 26kA    | 35kA    |

# About This Manual

This operation manual describes the specifications of the SV-iS7 series inverters and provides detailed information required for the installation, operation, and maintenance of the products.

This operation manual is intended for users with a basic knowledge of electricity and electric devices. Read this manual carefully to install, operate, and maintain the products safely and properly.

The following table lists the chapters in this manual, and brief descriptions of the information provided:

| Chapter | Chapter name                      | Information provided  |
|---------|-----------------------------------|---|
| 1       | About the Product                 | Basic information about the product that is required for safe installation and operation  |
| 2       | Technical Specifications          | Product ratings and I/O types   |
| 3       | Installing the Inverter           | Information required for the installation of the product, including considerations for installation locations and operation environment |
| 4       | Connecting the Cables             | Information required for connecting power supply and signal cables  |
| 5       | Peripheral Devices                | Information about the peripheral devices that can be connected to the input and output terminals of the product                         |
| 6       | Using the Keypad                  | Information about the keypad display and the operation keys on the keypad   |
| 7       | Basic Functions                   | Information about configuring the inverter to run the basic functions   |
| 8       | Learning Advanced Features        | Information about configuring the inverter for advanced system application  |
| 9       | Using Monitor Functions           | Information about monitoring the inverter for operation statuses and trip conditions  |
| 10      | Using Protection Features         | Information about the functions to protect the motor and the inverter   |
| 11      | Communication Function            | Specifications for the RS-485 network communication between inverters and other devices   |
| 12      | Troubleshooting and Maintenance   | Information about identifying the failures and anomalies during operation and resolving them  |
| 13      | Table of Functions                | Table of all functions with brief descriptions  |
| 14      | Functional Safety                 | Information about the products compliant with the safety standards, and the safety functions  |
| 15      | Classified Product                | Information about the products approved for marine application  |
| 16      | Using a Single Phase Power Source | Considerations for operating the inverter with a single phase power source  |



# Table of Contents

|          |  |           |
|----------|--|-----------|
| <b>1</b> | <b>About the Product.....</b>  | <b>1</b>  |
| 1.1      | Preparing for Installation and Operation.....  | 1         |
| 1.1.1    | Identifying the Product .....  | 1         |
| 1.1.2    | Checking the Product for Defects or Damage .....   | 3         |
| 1.1.3    | Preparing the Product for Installation and Operation .....   | 3         |
| 1.1.4    | Installing the Product.....  | 3         |
| 1.1.5    | Connecting the Cables .....  | 3         |
| 1.2      | Part Names .....   | 4         |
| 1.2.1    | Interior and Exterior View (IP 21 Model Types Less than 22 kW [200 V] /<br>Less than 75 kW [400 V])..... | 4         |
| 1.2.2    | Interior and Exterior View (IP 54 Model Types Less than 22 kW [200/400<br>V]).....                       | 5         |
| 1.2.3    | Interior and Exterior View (Model Types 30 kW and up [200 V] / 90 kW<br>and up [400 V]).....             | 6         |
| <b>2</b> | <b>Technical Specifications .....</b>  | <b>7</b>  |
| 2.1      | Input and Output Specifications 200 V Class (0.75–22 kW).....  | 7         |
| 2.2      | Input and Output Specifications 200 V Class (30–75 kW).....  | 8         |
| 2.3      | Input and Output Specifications 400 V Class (0.75–22 kW).....  | 9         |
| 2.4      | Input and Output Specifications 400 V Class (30–160 kW).....   | 10        |
| 2.5      | Input and Output Specifications 400 V Class (185–375 kW).....  | 11        |
| 2.6      | Product Specification Details .....  | 13        |
| 2.6.1    | Control .....  | 13        |
| 2.6.2    | Operation.....   | 13        |
| 2.6.3    | Protection Function .....  | 15        |
| 2.6.4    | Structure and Operating Environment Control.....   | 15        |
| <b>3</b> | <b>Installing the Inverter .....</b>   | <b>17</b> |
| 3.1      | Installation Considerations .....  | 17        |
| 3.2      | Selecting and Preparing a Site for Installation .....  | 18        |
| 3.3      | Exterior and Dimensions (UL Enclosed Type 1, IP21 Type) .....  | 22        |
| 3.4      | Exterior and Dimensions (UL Enclosed Type 12, IP54 Type) .....   | 36        |
| 3.5      | Frame Dimensions and Weight (UL Enclosed Type 1, IP 21 Type) .....                                       | 40        |
| 3.6      | Frame Dimensions and Weight (UL Enclosed Type 12, IP54 Type) .....                                       | 42        |
| 3.7      | Installation Procedures for UL Enclosed Type12 and IP54 Type Products.....                               | 43        |
| 3.7.1    | Disassembling the Keypad Cover and Keypad.....   | 43        |
| 3.7.2    | Disassembling the IP54 Front Cover .....   | 44        |
| 3.7.3    | Mounting the Inverter .....  | 45        |
| 3.7.4    | Connecting the Power Cables .....  | 46        |
| 3.7.5    | Reassembling the IP54 Front Cover and the Keypad .....   | 47        |
| <b>4</b> | <b>Connecting the Cables.....</b>  | <b>49</b> |
| 4.1      | Removing the Front Cover for Cable Connection.....   | 49        |
| 4.1.1    | IP 21 Type Products.....   | 49        |

|          |  |           |
|----------|--|-----------|
| 4.12     | IP 54 Type Products.....   | 51        |
| 4.13     | 90–375 kW, 400 V and 30–75 kW, 200 V Products.....                     | 52        |
| 4.2      | Activating and Deactivating the Built-in EMC Filter.....               | 53        |
| 4.2.1    | Up to 7.5 kW Inverters .....   | 53        |
| 4.2.2    | 11–22 kW Inverters .....   | 55        |
| 4.3      | Precautions for Wiring the Inverter .....                              | 57        |
| 4.4      | Ground Connection .....  | 58        |
| 4.5      | Terminal Wiring Diagram.....   | 59        |
| 4.5.1    | Up to 7.5 kW Inverters .....   | 59        |
| 4.5.2    | 11–22 kW Inverters .....   | 59        |
| 4.5.3    | 30–75 kW Inverters.....  | 59        |
| 4.5.4    | 90–160 kW Inverters.....   | 59        |
| 4.5.5    | 185–220 kW Inverters.....  | 60        |
| 4.5.6    | 280–375 kW Inverters.....  | 60        |
| 4.6      | Connecting Cables to the Power Terminal Block.....                     | 61        |
| 4.6.1    | 0.75–22 kW (200 V/400 V).....  | 61        |
| 4.6.2    | 30–75 kW (200 V/400 V).....  | 62        |
| 4.6.3    | 90–160 kW (400 V).....   | 63        |
| 4.6.4    | 185–220 kW (400 V).....  | 64        |
| 4.6.5    | 280–375 kW (200 V/400 V).....  | 64        |
| 4.7      | Specifications of the Power Terminal Block and Exterior Fuse.....      | 66        |
| 4.7.1    | Cable Length between the Inverter and the Motor.....                   | 67        |
| 4.7.2    | Protective Measures for the Inverter and the Motor.....                | 68        |
| 4.8      | Control Terminal Wiring for iS7 Inverters Rated for Up To 22 kW.....   | 69        |
| 4.8.1    | NPN Mode (Sink) .....  | 70        |
| 4.8.2    | PNP Mode (Source).....   | 70        |
| 4.8.3    | 0.75–22 kW (Basic I/O).....  | 71        |
| 4.9      | Control Terminal Wiring for iS7 Inverters Rated for 30 kW or More..... | 72        |
| 4.10     | Terminal Inputs for Inverter Operation .....                           | 73        |
| 4.11     | Cable Specifications for Control Block Wiring.....                     | 75        |
| 4.12     | Control Terminal Wiring for iS7 Extension I/O (Optional).....          | 76        |
| 4.13     | Terminal Inputs for Inverter Operation .....                           | 77        |
| 4.14     | Cable Specifications for Control Block Wiring.....                     | 78        |
| 4.15     | Setting the Built-in Surge Filter .....                                | 79        |
| 4.16     | Activating or Deactivating the Surge Filter .....                      | 80        |
| 4.16.1   | iS7 30–75kW (400 V) Inverters.....                                     | 80        |
| 4.16.2   | iS7 90–375 kW (400V) Inverters .....                                   | 80        |
| 4.17     | Post-Installation Checklist.....                                       | 82        |
| 4.18     | Test Run .....   | 83        |
| 4.18.1   | Entering Easy Start Mode .....   | 83        |
| 4.18.2   | Setting the Basic Parameters in Easy Start Mode .....                  | 84        |
| 4.18.3   | Checking the Inverter Operation.....                                   | 85        |
| <b>5</b> | <b>Peripheral Devices .....</b>  | <b>86</b> |
| 5.1      | Wiring Switch, Electronic Contactor, and Reactor Specifications .....  | 87        |

|          |   |            |
|----------|---|------------|
| 5.1.1    | Wiring Switch, Short Circuit Switch, and Electronic Contactor ..... | 87         |
| 5.1.2    | Reactors .....  | 89         |
| 5.1.3    | Dynamic Braking Unit (DBU) and Resistor .....                       | 92         |
| 5.1.4    | DB Unit Dimensions.....   | 96         |
| 5.1.5    | Indicators on the DB unit .....                                     | 102        |
| 5.1.6    | DB Resistors .....  | 102        |
| 5.1.7    | DB Resistor Dimensions .....  | 105        |
| 5.1.8    | Keypad Extension Cable for Remote Control (Optional).....           | 106        |
| <b>6</b> | <b>Using the Keypad.....</b>  | <b>109</b> |
| 6.1      | About the Keypad .....  | 109        |
| 6.1.1    | Dimensions .....  | 109        |
| 6.1.2    | Key Functions .....   | 110        |
| 6.1.3    | Display Items.....  | 111        |
| 6.1.4    | Display Item List .....   | 111        |
| 6.2      | Menu Items .....  | 114        |
| 6.2.1    | Parameter Mode.....   | 115        |
| 6.2.2    | User & Macro Mode .....   | 116        |
| 6.3      | Navigating Modes.....   | 117        |
| 6.3.1    | Mode Navigation at the Factory Default .....                        | 117        |
| 6.3.2    | Mode Navigation with User/Macro Mode and Trip Mode .....            | 118        |
| 6.4      | Navigating Modes and Parameters .....                               | 120        |
| 6.4.1    | Group Navigation in Parameter mode .....                            | 120        |
| 6.4.2    | Group Shift in User & Macro Mode .....                              | 122        |
| 6.5      | Navigating through Codes (Function Items) .....                     | 123        |
| 6.5.1    | Code Navigation in Monitor Mode .....                               | 123        |
| 6.5.2    | Code Navigation (function items) in Other Modes and Groups .....    | 124        |
| 6.5.3    | Code Navigation Using Jump Code.....                                | 125        |
| 6.6      | Setting Parameters.....   | 127        |
| 6.6.1    | Parameter Settings in Monitor Mode .....                            | 127        |
| 6.6.2    | Parameter Settings in Other Modes and Groups .....                  | 128        |
| 6.7      | Monitoring Operating Status .....                                   | 129        |
| 6.7.1    | Using Monitor Mode.....   | 129        |
| 6.7.2    | Monitoring Items .....  | 130        |
| 6.7.3    | Using the Status Display .....                                      | 131        |
| 6.8      | Monitoring Faults .....   | 132        |
| 6.8.1    | Faults during Inverter Operation .....                              | 132        |
| 6.8.2    | Multiple Faults at a Time during Inverter Operation .....           | 133        |
| 6.8.3    | Saving and Monitoring the Fault Trip History .....                  | 133        |
| 6.9      | Initializing Parameters .....                                       | 135        |
| <b>7</b> | <b>Basic Functions.....</b>   | <b>137</b> |
| 7.1      | Setting Frequency References .....                                  | 137        |
| 7.1.1    | Keypad as the Source (KeyPad-1 setting).....                        | 138        |
| 7.1.2    | Keypad as the Source (KeyPad-2 setting).....                        | 138        |
| 7.1.3    | V1 Terminal as the Source .....                                     | 138        |
| 7.1.4    | Setting a Frequency Reference Using an I/O Expansion Module .....   |            |

|        |   |     |
|--------|---|-----|
|        | (Terminal V2/I2).....   | 148 |
| 7.15   | Setting a Frequency with Pulse Input (with an optional encoder module) .....            | 150 |
| 7.16   | Setting a Frequency Reference via RS-485 Communication.....                             | 152 |
| 7.2    | Frequency Hold by Analog Input .....  | 153 |
| 7.3    | Changing the Displayed Units (Hz↔Rpm) .....   | 154 |
| 7.4    | Setting Multi-Step Frequency.....   | 154 |
| 7.5    | Command Source Configuration .....  | 157 |
| 7.5.1  | The Keypad as a Command Input Device .....  | 157 |
| 7.5.2  | The Terminal Block as a Command Input Device (Fwd/Rev run commands).....                | 158 |
| 7.5.3  | The Terminal Block as a Command Input Device (Run and Rotation Direction Commands)..... | 159 |
| 7.5.4  | RS-485 Communication as a Command Input Device.....                                     | 160 |
| 7.6    | Local/Remote Mode Switching .....   | 160 |
| 7.7    | Forward or Reverse Run Prevention.....  | 162 |
| 7.8    | Power-on Run.....   | 163 |
| 7.9    | Reset and Restart.....  | 164 |
| 7.10   | Setting Acceleration and Deceleration Times .....                                       | 165 |
| 7.10.1 | Acc/Dec Time Based on Maximum Frequency .....   | 165 |
| 7.10.2 | Acc/Dec Time Based on Operation Frequency .....   | 167 |
| 7.10.3 | Multi-Step Acc/Dec Time Configuration .....   | 168 |
| 7.10.4 | Configuring Acc/Dec Time Switch Frequency.....  | 169 |
| 7.11   | Acc/Dec Pattern Configuration .....   | 171 |
| 7.12   | Stopping the Acc/Dec Operation .....  | 173 |
| 7.13   | V/F (Voltage/Frequency) Control .....   | 174 |
| 7.13.1 | Linear V/F Pattern Operation.....   | 174 |
| 7.13.2 | Square Reduction V/F Pattern Operation .....  | 174 |
| 7.13.3 | User V/F Pattern Operation.....   | 176 |
| 7.14   | Torque Boost.....   | 178 |
| 7.14.1 | Manual Torque Boost.....  | 178 |
| 7.14.2 | Auto Torque Boost.....  | 179 |
| 7.14.3 | Advanced Auto Torque Boost .....  | 179 |
| 7.15   | Output Voltage Setting .....  | 181 |
| 7.16   | Start Mode Setting.....   | 182 |
| 7.16.1 | Acceleration Start .....  | 182 |
| 7.16.2 | Start After DC Braking.....   | 182 |
| 7.17   | Stop Mode Setting .....   | 183 |
| 7.17.1 | Deceleration Stop .....   | 183 |
| 7.17.2 | Stop after DC Braking.....  | 184 |
| 7.17.3 | Free Run Stop .....   | 185 |
| 7.17.4 | Power Braking .....   | 186 |
| 7.18   | Frequency Limit .....   | 186 |
| 7.18.1 | Frequency Limit Using Maximum Frequency and Start Frequency.....                        | 186 |
| 7.18.2 | Frequency Limit Using Upper and Lower Limit Frequency Values .....                      | 187 |



|          |  |            |
|----------|--|------------|
| 7.18.3   | Frequency Jump.....  | 189        |
| 7.19     | 2 <sup>nd</sup> Operation Mode Setting.....                          | 190        |
| 7.20     | Multi-function Input Terminal Control.....                           | 192        |
| 7.21     | Expanded I/O Control with an Optional I/O Expansion Module.....      | 193        |
| <b>8</b> | <b>Learning Advanced Features.....</b>                               | <b>194</b> |
| 8.1      | Operating with Auxiliary References.....                             | 194        |
| 8.2      | Jog Operation.....   | 199        |
| 8.2.1    | Jog Operation 1-Forward Jog via Multi-function Terminal.....         | 199        |
| 8.2.2    | Jog Operation 2-Forward/Reverse Jog via Multi-function Terminal..... | 200        |
| 8.2.3    | Jog Operation via Keypad Input.....                                  | 201        |
| 8.3      | Up/down Operation.....   | 202        |
| 8.4      | 3-Wire Operation.....  | 206        |
| 8.5      | Safe Operation Mode.....   | 207        |
| 8.6      | Dwell Operation.....   | 208        |
| 8.7      | Slip Compensation Operation.....                                     | 210        |
| 8.8      | PID Control.....   | 212        |
| 8.8.1    | PID Basic Operation.....   | 213        |
| 8.8.2    | Pre-PID Operation.....   | 218        |
| 8.8.3    | PID Sleep Mode.....  | 219        |
| 8.8.4    | PID Switching (PID Openloop).....                                    | 220        |
| 8.9      | Auto Tuning.....   | 220        |
| 8.10     | V/F Operation Using Speed Sensor.....                                | 225        |
| 8.11     | Sensorless-1 Vector Control.....                                     | 225        |
| 8.12     | Sensorless-2 Vector Control.....                                     | 227        |
| 8.13     | Vector Control Mode Operation.....                                   | 231        |
| 8.14     | Torque Control.....  | 236        |
| 8.15     | Droop Control.....   | 238        |
| 8.16     | Speed / Torque Control Switching.....                                | 238        |
| 8.17     | Kinetic Energy Buffering.....  | 239        |
| 8.18     | Energy Saving Operation.....   | 242        |
| 8.18.1   | Manual Energy Saving Operation.....                                  | 242        |
| 8.18.2   | Automatic Energy Saving Operation.....                               | 242        |
| 8.19     | Speed Search Operation.....  | 244        |
| 8.20     | Auto Restart Settings.....   | 247        |
| 8.21     | Operational Noise Settings (Carrier Frequency Settings).....         | 248        |
| 8.22     | 2nd Motor Operation.....   | 251        |
| 8.23     | Supply Power Transition.....   | 253        |
| 8.24     | Cooling Fan Control.....   | 254        |
| 8.25     | Input Power Frequency Settings.....                                  | 255        |
| 8.26     | Input Power Voltage Settings.....                                    | 256        |
| 8.27     | Read, Write, and Save Parameters.....                                | 256        |
| 8.28     | Parameter Initialization.....  | 257        |

|          |   |            |
|----------|---|------------|
| 8.29     | Parameter Viewing and Lock Options .....  | 258        |
| 8.29.1   | Parameter View Lock .....   | 258        |
| 8.29.2   | Parameter Lock .....  | 259        |
| 8.29.3   | Changed Parameter Display .....   | 260        |
| 8.30     | User Group .....  | 260        |
| 8.31     | Macro Selection .....   | 262        |
| 8.32     | Easy Start .....  | 263        |
| 8.33     | Config (CNF) Mode .....   | 264        |
| 8.34     | Timer Settings .....  | 265        |
| 8.35     | Traverse Operation .....  | 266        |
| 8.36     | Brake Control .....   | 267        |
| 8.37     | Multi-function Output On/Off Control .....  | 269        |
| 8.38     | MMC function .....  | 270        |
| 8.38.1   | Basic MMC Operation .....   | 272        |
| 8.38.2   | Auto Change Operation .....   | 273        |
| 8.38.3   | Interlock Operation .....   | 275        |
| 8.38.4   | Bypass Operation (Regular Bypass) .....   | 277        |
| 8.39     | Press Regeneration Prevention (To evade control operation in the status of regeneration during press) ..... | 278        |
| 8.40     | Anti-Hunting Regulator .....  | 279        |
| 8.41     | Fire Mode .....   | 280        |
| 8.42     | Dynamic Braking (DB) Resistor Operation Reference Voltage .....   | 282        |
| 8.43     | kW/HP Unit Selection .....  | 282        |
| <b>9</b> | <b>Using Monitor Functions .....</b>  | <b>284</b> |
| 9.1      | Monitoring the Operating Status via the Keypad .....  | 284        |
| 9.1.1    | Selecting Monitor Mode Display .....  | 284        |
| 9.1.2    | Displaying Output Power .....   | 286        |
| 9.1.3    | Selecting Load Speed Display .....  | 287        |
| 9.1.4    | Selecting Hz/Rpm Display .....  | 287        |
| 9.1.5    | Selecting Status Display .....  | 288        |
| 9.1.6    | Monitoring Output Frequency .....   | 288        |
| 9.2      | Monitoring Fault Status Using Keypad .....  | 289        |
| 9.2.1    | Monitoring Current Fault Status .....   | 289        |
| 9.2.2    | Monitoring Fault Trip History .....   | 290        |
| 9.3      | Analog output .....   | 291        |
| 9.3.1    | Voltage Output (0–10 V) .....   | 291        |
| 9.3.2    | Current Output (4–20 mA) .....  | 293        |
| 9.3.3    | Voltage Output (-10–+10V) Using an I/O Expansion Module .....   | 296        |
| 9.3.4    | Current Output (4–20 mA/0–20 mA) Using an I/O Expansion Module .....  | 297        |
| 9.4      | Relay Output and Multi-function Output Terminal Settings .....  | 298        |
| 9.5      | Fault trip output using multi-function output terminals and relays .....                                    | 304        |
| 9.6      | Output Terminal Delay Time and Terminal Types .....   | 305        |
| 9.6.1    | Output Terminal Delay Time .....  | 305        |
| 9.6.2    | Setting the Output Terminal Type .....  | 305        |

|           |   |            |
|-----------|---|------------|
| 9.7       | Operation Time Monitor .....  | 306        |
| 9.8       | Setting the Keypad Language .....   | 307        |
| <b>10</b> | <b>Using Protection Features .....</b>  | <b>308</b> |
| 10.1      | Motor Protection .....  | 308        |
| 10.1.1    | Electrothermal Motor Overheating Prevention (ETH).....                              | 308        |
| 10.1.2    | Overload Early Warning and Trip .....   | 310        |
| 10.1.3    | Stall Prevention and Flux Braking .....   | 311        |
| 10.1.4    | Motor Overheat Sensor Input .....   | 315        |
| 10.2      | Inverter and Sequence Protection .....  | 316        |
| 10.2.1    | Open-phase Protection.....  | 317        |
| 10.2.2    | External Trip Signal .....  | 318        |
| 10.2.3    | Inverter Overload Protection (IOLT) .....   | 319        |
| 10.2.4    | Keypad Command Loss.....  | 319        |
| 10.2.5    | Speed Command Loss.....   | 321        |
| 10.2.6    | Dynamic Braking (DB) Resistor Configuration.....                                    | 322        |
| 10.2.7    | Underload Warning and Failure.....  | 324        |
| 10.2.8    | Overspeed Fault.....  | 325        |
| 10.2.9    | Speed Deviation Fault.....  | 325        |
| 10.2.10   | Speed Sensor (Encoder) Fault Detection .....  | 326        |
| 10.2.11   | Fan Fault Detection .....   | 327        |
| 10.2.12   | Low Voltage Fault Trip .....  | 327        |
| 10.2.13   | Output Block via the Multi-Function Terminal.....                                   | 328        |
| 10.2.14   | Trip Status Reset.....  | 329        |
| 10.2.15   | Operation Mode On Optional Expansion Module Fault Trip .....                        | 329        |
| 10.2.16   | No Motor Trip .....   | 330        |
| 10.2.17   | Low Voltage Fault Trip 2 During Operation .....                                     | 330        |
| 10.3      | List of Faults and Warnings.....  | 331        |
| <b>11</b> | <b>Communication Function .....</b>   | <b>334</b> |
| 11.1      | Introduction .....  | 334        |
| 11.2      | Specifications .....  | 335        |
| 11.3      | Communication System Configuration.....   | 336        |
| 11.4      | Basic Settings .....  | 337        |
| 11.5      | Setting Operation Command and Frequency .....                                       | 338        |
| 11.6      | Command Loss Protection .....   | 338        |
| 11.7      | Setting Virtual Multi-Function inputs .....   | 339        |
| 11.8      | Saving Parameters Defined by Communication.....                                     | 340        |
| 11.9      | Communication Frame Monitoring .....  | 341        |
| 11.10     | Special communication Area Settings .....   | 341        |
| 11.11     | Parameter Group for Periodical Data Transmission .....                              | 342        |
| 11.12     | Parameter Group for Transmission of Macro Group and User Group at<br>U&M Mode ..... | 344        |
| 11.13     | Communication Protocol.....   | 344        |
| 11.13.1   | LS INV 485 Protocol.....  | 344        |
| 11.13.2   | Modbus-RTU protocol.....  | 350        |

|           |  |            |
|-----------|--|------------|
| 11.13.3   | iS7/iS5/iG5/iG5A Compatible Common Area Parameter .....  | 352        |
| 11.13.4   | Expansion Common Area Parameter .....  | 356        |
| <b>12</b> | <b>Troubleshooting and Maintenance .....</b>   | <b>369</b> |
| 12.1      | Protection Functions .....   | 369        |
| 12.1.1    | Protection from Output Current and Input Voltage .....   | 369        |
| 12.1.2    | Abnormal Circuit Conditions and External Signals .....   | 370        |
| 12.1.3    | Keypad and Optional Expansion Modules .....  | 372        |
| 12.2      | Warning Messages .....   | 373        |
| 12.3      | Troubleshooting Fault Trips .....  | 374        |
| 12.4      | Replacing the Cooling Fan .....  | 377        |
| 12.4.1    | Products Rated below 7.5 kW .....  | 377        |
| 12.4.2    | Products Rated at 11-15 kW 200 V/400 V and 18.5-22 kW 400 V .....  | 377        |
| 12.4.3    | Products Rated at more than 30 kW (200 V) / 90 kW (400 V), and 18.5–<br>22 kW (200 V) / 30–75 kW (200/400 V) ..... | 378        |
| 12.5      | Daily and Regular Inspection Lists .....   | 378        |
| <b>13</b> | <b>Table of Functions .....</b>  | <b>382</b> |
| 13.1      | Parameter Mode – DRV Group (→DRV) .....  | 382        |
| 13.2      | Parameter Mode – Basic Function Group (→BAS) .....   | 385        |
| 13.3      | Parameter Mode – Expansion Function Group (PAR→ADV) .....  | 389        |
| 13.4      | Parameter Mode – Control Function Group (→CON) .....   | 393        |
| 13.5      | Parameter Mode – Input Terminal Block Function Group (→IN) .....   | 399        |
| 13.6      | Parameter Mode – Output Terminal Block Function Group (→OUT) .....   | 403        |
| 13.7      | Parameter Mode – Communication Function Group (→COM) .....   | 407        |
| 13.8      | Parameter Mode – Applied Function Group (→APP) .....   | 410        |
| 13.9      | Parameter Mode – Option Module Function Group (→APO) .....   | 413        |
| 13.10     | Parameter Mode – Protective Function Group (→PRT) .....  | 416        |
| 13.11     | Parameter Mode – 2nd Motor Function Group (→M2) .....  | 419        |
| 13.12     | Trip Mode (TRP Current (or Last-x)) .....  | 420        |
| 13.13     | Config Mode (CNF) .....  | 420        |
| 13.14     | User/Macro Mode – Draw Operation Function Group →MC1 .....   | 423        |
| 13.15     | User/Macro mode – Traverse Operation Function Group (→MC2) .....   | 424        |
| <b>14</b> | <b>Safety Functon STO(Safe Torque Off) .....</b>   | <b>425</b> |
| 14.1      | Safety Standard Product .....  | 425        |
| 14.2      | About the Safety Function .....  | 425        |
| 14.2.1    | Safety Function Wiring Diagram .....   | 426        |
| 14.2.2    | Installing the Safety Board to 0.75–160 kW Product .....   | 427        |
| 14.2.3    | Installing the Safety Board to 185–375 kW Product .....  | 427        |
| 14.2.4    | Safety Function Terminal Description .....   | 428        |
| 14.2.5    | Cable Specification for Signal Terminal Block Wiring .....   | 428        |
| <b>15</b> | <b>Marine Certification .....</b>  | <b>429</b> |
| 15.1      | DNV (Det Norske Veritas) Marine Certification Details .....  | 429        |
| 15.2      | Bureau Veritas (Marine & Offshore Division) Marine Certification Details .....                                     | 429        |

|           |  |            |
|-----------|--|------------|
| 15.3      | ABS Marine Certification Details.....                | 429        |
| 15.4      | KR Marine Certification Details .....                | 429        |
| 15.5      | Marine Certification Models for SV-iS7 Products..... | 430        |
| <b>16</b> | <b>Using a Single Phase Power Source .....</b>       | <b>432</b> |
| 16.1      | Single Phase Rating.....                             | 432        |
| 16.2      | Power(HP), Input Current and Output Current .....    | 433        |
| 16.3      | Input Frequency and Voltage Tolerance.....           | 434        |
| 16.4      | Wiring and Peripheral Device .....                   | 434        |
| 16.5      | Other Considerations .....                           | 437        |
| <b>17</b> | <b>Storage and Disposal .....</b>                    | <b>438</b> |
| 17.1      | Storage.....   | 438        |
| 17.2      | Disposal .....                                       | 438        |
|           | <b>Product Warranty.....</b>                         | <b>442</b> |
|           | <b>Index.....</b>                                    | <b>444</b> |



# 1 About the Product

This chapter provides details on product identification and part names. To install the inverter correctly and safely, carefully read and follow the instructions.

## 1.1 Preparing for Installation and Operation

### 1.1.1 Identifying the Product

Check the product name, open the packaging, and then confirm that the product is free from defects. Contact your supplier if you have any issues or questions about your product.

The iS7 inverter is manufactured in a range of product groups based on drive capacity and power source specifications. The product name and specifications are detailed on the rating plate. Check the rating plate before installing the product and make sure that the product meets your requirements.



**Model name**  
SV008iS7-2NOFDW

**Power source specifications**  
INPUT 380-480V 3 Phase 50/60Hz  
Heavy Duty : 26.6A, Normal Duty : 35.5A

**Output specifications**  
OUTPUT 0-Input V 3 Phase 0.01-400Hz  
Heavy Duty : 30A, Normal Duty : 39A  
22.9kVA  
Ser. No 550XXXXXXX  
Inspected by D. K. YU  
KCC-REM-LSR-XXXXXXX

**SV 008 iS7-2 N O F D W**

| INV Model | Motor Capacity   |                 |
|-----------|------------------|-----------------|
|           | VT (Normal duty) | CT (Heavy duty) |
| 0008      | 1.5 [kW]         | 0.75 [kW]       |
| 0015      | 2.2 [kW]         | 1.5 [kW]        |
| 0022      | 3.7 [kW]         | 2.2 [kW]        |
| 0037      | 5.5 [kW]         | 3.7 [kW]        |
| 0055      | 7.5 [kW]         | 5.5 [kW]        |
| 0075      | 11 [kW]          | 7.5 [kW]        |
| 0110      | 15 [kW]          | 11 [kW]         |
| 0150      | 18.5 [kW]        | 15 [kW]         |
| 0185      | 22 [kW]          | 18.5 [kW]       |
| 0220      | 30 [kW]          | 22 [kW]         |
| 0300      | 37 [kW]          | 30 [kW]         |
| 0370      | 45 [kW]          | 37 [kW]         |
| 0450      | 55 [kW]          | 45 [kW]         |
| 0550      | 75 [kW]          | 55 [kW]         |
| 0750      | 90 [kW]          | 75 [kW]         |
| 0900      | 110 [kW]         | 90 [kW]         |
| 1100      | 132 [kW]         | 110 [kW]        |
| 1320      | 160 [kW]         | 132 [kW]        |
| 1600      | 185 [kW]         | 160 [kW]        |
| 1850      | 220 [kW]         | 185 [kW]        |
| 2200      | 280 [kW]         | 220 [kW]        |
| 2800      | 315 [kW]         | 280 [kW]        |
| 3150      | 375 [kW]         | 315 [kW]        |
| 3750      | 450 [kW]         | 375 [kW]        |

**Application type**  
W - Web  
S - Synchro  
T - Safety  
V - Marine class

**DC Reactor or DB Resistor**  
- No built-in DC reactor nor DB resistor  
D - Built-in DC reactor  
R - Built-in DB resistor

**EMC filter**  
- No-EMC  
F - Built-in EMC

**UL type**  
O - Open  
E - Enclosed UL Type1  
P - Enclosed UL Type 12

**Keypad type**  
N - No keypad present  
S - GLCD Keypad

**Input voltage**  
2 - 3-phase 200-230 V  
4 - 3-phase 380-480 V

Note1) Optional conduit parts are available for the Enclosed UL Type 1 models (0.75–75 kW products).

Note2) Built-in DB resistor is available only for the Web application models (0.75–3.7 kW products).

Note3) To use safety function, please buy 0.75-160kW product including safety option. However 185-375kW product users have to buy safety option and apply to standard products because safety option is not included.

## 1.1.2 Checking the Product for Defects or Damage

If you suspect that the product has been mishandled or damaged in any way, contact the LS ELECTRIC Customer Support center with the phone numbers listed on the back cover of this manual.

## 1.1.3 Preparing the Product for Installation and Operation

Preparation steps for installation and operation may slightly vary by product type and application. Refer to the manual and prepare the product accordingly.

## 1.1.4 Installing the Product

Refer to the installation section of this manual and install the product correctly considering the installation and operating conditions at the installation location, such as installation clearances, to prevent premature deterioration or performance loss.

## 1.1.5 Connecting the Cables

Connect the power input/output and signal cables to the terminal block according to the instructions provided in this manual. Ensure that all the cables are connected correctly before supplying power to the product. Incorrect cable connections may damage the product.

## 1.2 Part Names

The illustration below displays part names. Details may vary between product groups.

### 1.2.1 Interior and Exterior View (IP 21 Model Types Less than 22 kW [200 V] / Less than 75 kW [400 V])

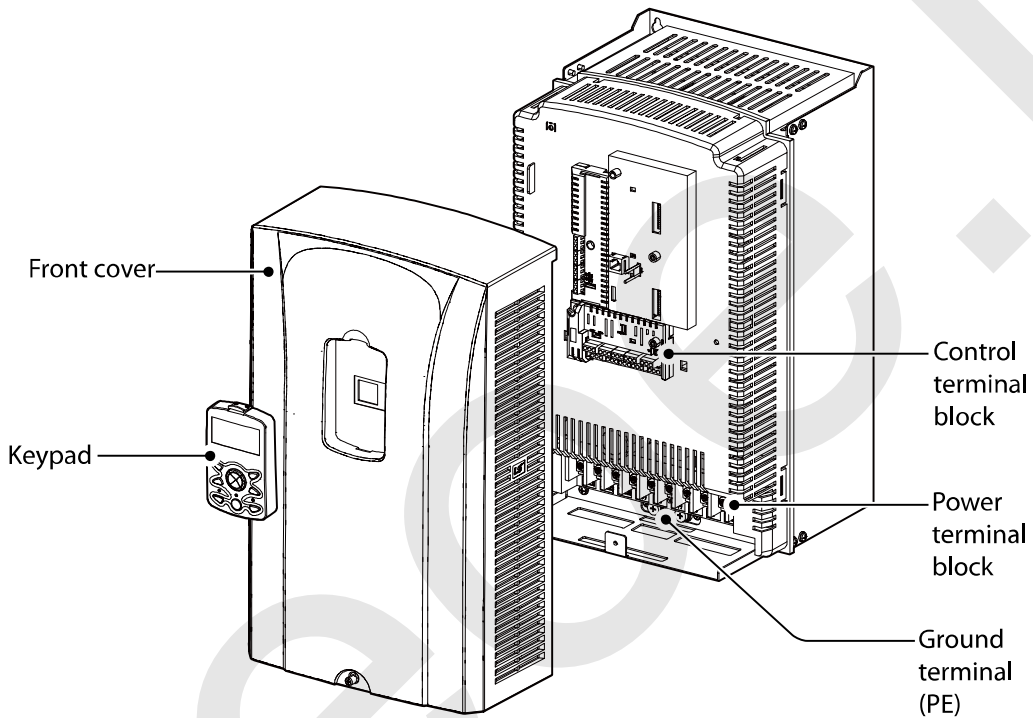

### 1.2.2 Interior and Exterior View (IP 54 Model Types Less than 22 kW [200/400 V])

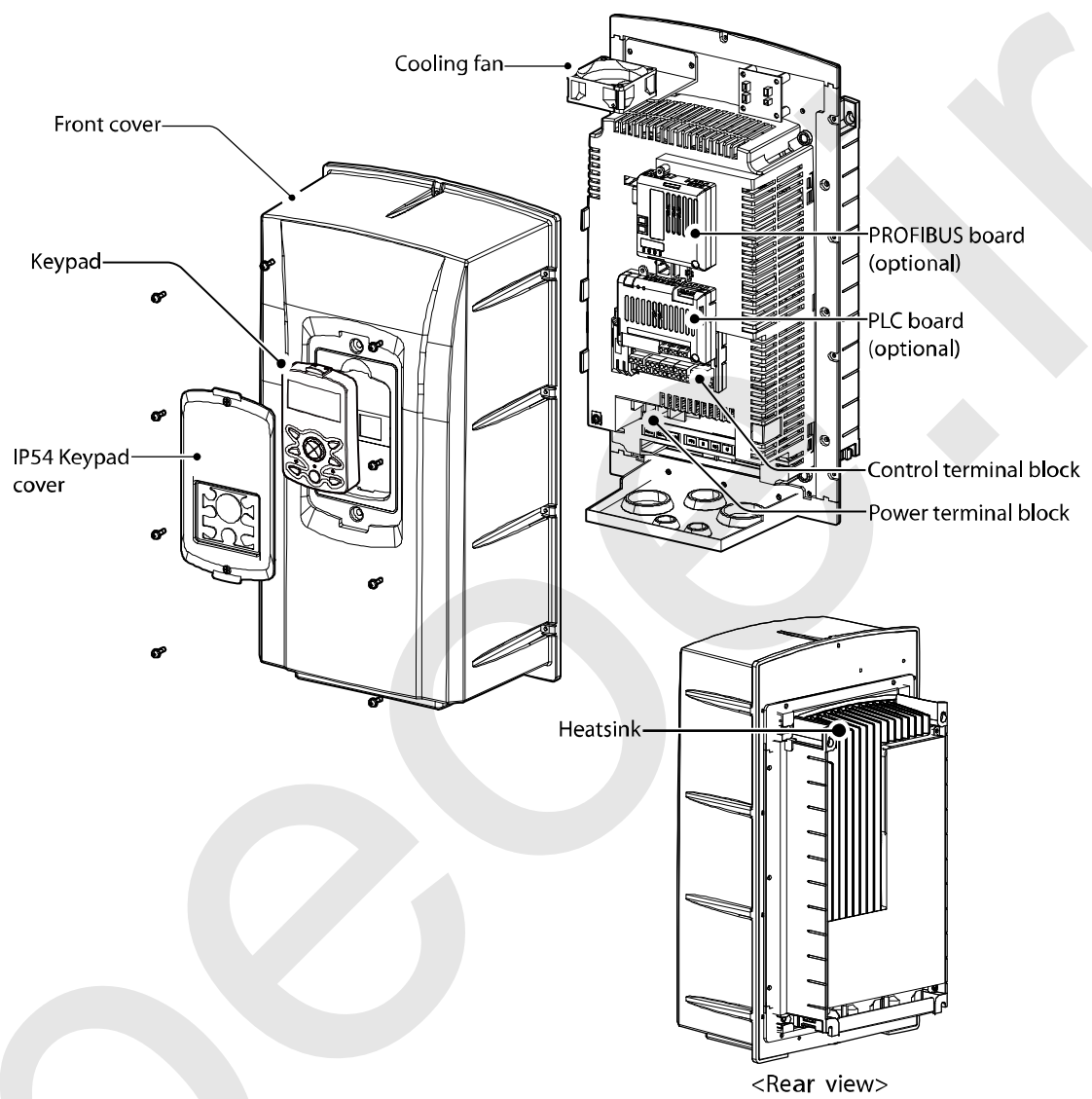

### 1.2.3 Interior and Exterior View (Model Types 30 kW and up [200 V] / 90 kW and up [400 V])

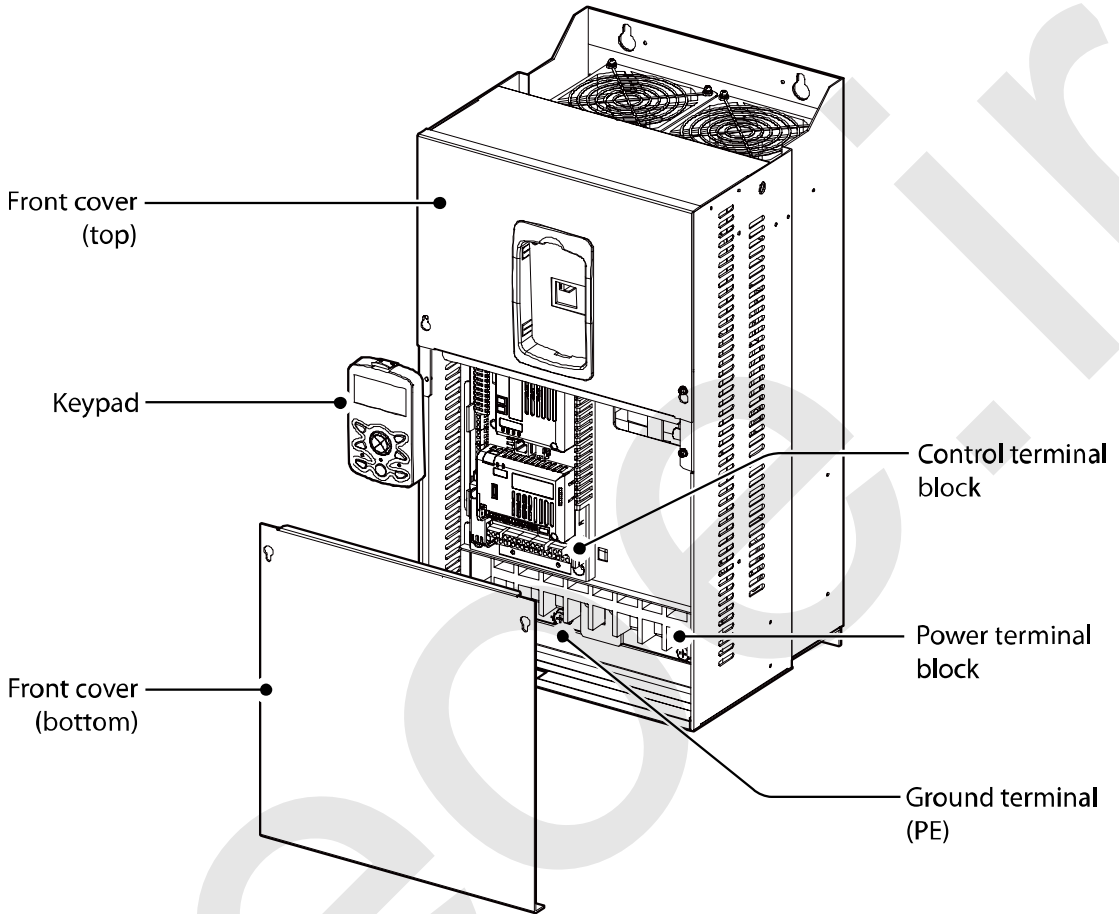

#### Note

Refer to the installation manual provided with the optional module products before installing communication modules in the inverter.

## 2 Technical Specifications

### 2.1 Input and Output Specifications 200 V Class (0.75–22 kW)

| Model SV xxx iS7–2x |                      |             | 0008  | 0015 | 0022 | 0037 | 0055 | 0075 | 0110 | 0150 | 0185 | 0220  |  |
|---------------------|----------------------|-------------|---|------|------|------|------|------|------|------|------|-------|--|
| Applied Motor       | Normal load          | HP          | 2   | 3    | 5    | 7.5  | 10   | 15   | 20   | 25   | 30   | 40    |  |
|                     |                      | kW          | 1.5   | 2.2  | 3.7  | 5.5  | 7.5  | 11   | 15   | 18.5 | 22   | 30    |  |
|                     | Heavy load           | HP          | 1   | 2    | 3    | 5    | 7.5  | 10   | 15   | 20   | 25   | 30    |  |
|                     |                      | kW          | 0.75  | 1.5  | 2.2  | 3.7  | 5.5  | 7.5  | 11   | 15   | 18.5 | 22    |  |
| Rated output        | Rated Capacity (kVA) |             | 1.9   | 3.0  | 4.5  | 6.1  | 9.1  | 12.2 | 17.5 | 22.9 | 28.2 | 33.5  |  |
|                     | Rated Current (A)    | Normal load | 8   | 12   | 16   | 24   | 32   | 46   | 60   | 74   | 88   | 124   |  |
|                     |                      | Heavy load  | 5   | 8    | 12   | 16   | 24   | 32   | 46   | 60   | 74   | 88    |  |
|                     | Output Frequency     |             | 0–400 Hz (Sensorless-1: 0–300 Hz, Sensorless-2, Vector: 0.1–120 Hz) |      |      |      |      |      |      |      |      |       |  |
|                     | Output Voltage (V)   |             | 3-Phase 200–230 V   |      |      |      |      |      |      |      |      |       |  |
| Rated input         | Working Voltage (V)  |             | 3-Phase 200–230 VAC (-15%–+10%)                                     |      |      |      |      |      |      |      |      |       |  |
|                     | Input Frequency      |             | 50–60 Hz (±5%)  |      |      |      |      |      |      |      |      |       |  |
|                     | Rated Current (A)    | Normal load | 6.8   | 10.6 | 14.9 | 21.3 | 28.6 | 41.2 | 54.7 | 69.7 | 82.9 | 116.1 |  |
|                     |                      | Heavy load  | 4.3   | 6.9  | 11.2 | 14.9 | 22.1 | 28.6 | 44.3 | 55.9 | 70.8 | 85.3  |  |

- Only the heavy duty ratings apply to model types without a built-in DC resistor (NON-DCR).
- The standard used for 200 V inverters is based on a 220 V supply voltage.
- The rated output current is limited based on the carrier frequency set at CON-04.
- The output frequency is limited to 0–300 Hz if DRV-09 (control mode) is set to “3 (Sensorless-1),” and to 0–120 Hz if DRV-09 (control mode) is set to “4 (Sensorless-3).”
- The maximum output voltage cannot exceed the input voltage of the power source.

## 2.2 Input and Output Specifications 200 V Class (30–75 kW)

| Model SV xxx iS7-2x |                      |             | 0300  | 0370 | 0450 | 0550 | 0750 |  |  |  |  |  |
|---------------------|----------------------|-------------|---|------|------|------|------|--|--|--|--|--|
| Applied Motor       | Normal load          | HP          | 50  | 60   | 75   | 100  | 125  |  |  |  |  |  |
|                     |                      | kW          | 37  | 45   | 55   | 75   | 90   |  |  |  |  |  |
|                     | Heavy load           | HP          | 40  | 50   | 60   | 75   | 100  |  |  |  |  |  |
|                     |                      | kW          | 30  | 37   | 45   | 55   | 75   |  |  |  |  |  |
| Rated output        | Rated Capacity (kVA) |             | 46  | 57   | 69   | 84   | 116  |  |  |  |  |  |
|                     | Rated Current (A)    | Normal load | 146   | 180  | 220  | 288  | 345  |  |  |  |  |  |
|                     |                      | Heavy load  | 116   | 146  | 180  | 220  | 288  |  |  |  |  |  |
|                     | Output Frequency     |             | 0–400 Hz (Sensorless-1: 0–300 Hz, Sensorless-2, Vector: 0.1–120 Hz) |      |      |      |      |  |  |  |  |  |
|                     | Output Voltage (V)   |             | 3-Phase 200–230 V   |      |      |      |      |  |  |  |  |  |
| Rated input         | Working Voltage (V)  |             | 3-Phase 200–230 VAC (-15%–+10%)                                     |      |      |      |      |  |  |  |  |  |
|                     | Input Frequency      |             | 50–60 Hz (±5%)  |      |      |      |      |  |  |  |  |  |
|                     | Rated Current (A)    | Normal load | 152   | 190  | 231  | 302  | 362  |  |  |  |  |  |
|                     |                      | Heavy load  | 121   | 154  | 191  | 233  | 305  |  |  |  |  |  |

- The standard motor capacity is based on a standard 4-pole motor.
- The standard used for 200 V inverters is based on a 200 V supply voltage.
- The rated output current is limited based on the carrier frequency set at CON-04.
- The output frequency is limited to 0–300 Hz if DRV-09 (control mode) is set to “3 (Sensorless-1),” and to 0–120 Hz if DRV-09 (control mode) is set to “4 (Sensorless-3).”
- The maximum output voltage cannot exceed the input voltage of the power source.



## 2.3 Input and Output Specifications 400 V Class (0.75–22 kW)

| Model SV xxx iS7–2x |                      |             | 0008  | 0015 | 0022 | 0037 | 0055 | 0075 | 0110 | 0150 | 0185 | 0220 |  |
|---------------------|----------------------|-------------|---|------|------|------|------|------|------|------|------|------|--|
| Applied Motor       | Normal load          | HP          | 2   | 3    | 5    | 7.5  | 10   | 15   | 20   | 25   | 30   | 40   |  |
|                     |                      | kW          | 1.5   | 2.2  | 3.7  | 5.5  | 7.5  | 11   | 15   | 18.5 | 22   | 30   |  |
|                     | Heavy load           | HP          | 1   | 2    | 3    | 5    | 7.5  | 10   | 15   | 20   | 25   | 30   |  |
|                     |                      | kW          | 0.75  | 1.5  | 2.2  | 3.7  | 5.5  | 7.5  | 11   | 15   | 18.5 | 22   |  |
| Rated output        | Rated Capacity (kVA) |             | 1.9   | 3.0  | 4.5  | 6.1  | 9.1  | 12.2 | 18.3 | 22.9 | 29.7 | 34.3 |  |
|                     | Rated Current (A)    | Normal load | 4   | 6    | 8    | 12   | 16   | 24   | 30   | 39   | 45   | 61   |  |
|                     |                      | Heavy load  | 2.5   | 4    | 6    | 8    | 12   | 16   | 24   | 30   | 39   | 45   |  |
|                     | Output Frequency     |             | 0–400 Hz (Sensorless-1: 0–300Hz, Sensorless-2, Vector: 0.1–120Hz) |      |      |      |      |      |      |      |      |      |  |
|                     | Output Voltage (V)   |             | 3-Phase 380–480 V   |      |      |      |      |      |      |      |      |      |  |
| Rated input         | Working Voltage (V)  |             | 3-Phase 380–480 VAC (-15%–+10%)                                   |      |      |      |      |      |      |      |      |      |  |
|                     | Input Frequency      |             | 50–60 Hz (±5%)  |      |      |      |      |      |      |      |      |      |  |
|                     | Rated Current (A)    | Normal load | 3.7   | 5.7  | 7.7  | 11.1 | 14.7 | 21.9 | 26.4 | 35.5 | 41.1 | 55.7 |  |
|                     |                      | Heavy load  | 2.2   | 3.6  | 5.5  | 7.5  | 11.0 | 14.4 | 22.0 | 26.6 | 35.6 | 41.6 |  |

- Only the heavy duty ratings apply to model types without a built-in DC resistor (NON- DCR).
- The standard motor capacity is based on a standard 4-pole motor.
- The standard used for 400 V inverters is based on a 440 V supply voltage.
- The rated output current is limited based on the carrier frequency set at CON-04.
- The output frequency is limited to 0-300 Hz if DRV-09 (control mode) is set to “3 (Sensorless-1),” and to 0-120 Hz if DRV-09 (control mode) is set to “4 (Sensorless-3).”
- The maximum output voltage cannot exceed the input voltage of the power source.

## 2.4 Input and Output Specifications 400 V Class (30–160 kW)

| Model SV xxx iS7-4x |                      |             | 0300  | 0370 | 0450  | 0550  | 0750  | 0900  | 1100  | 1320  | 1600  |  |  |
|---------------------|----------------------|-------------|---|------|-------|-------|-------|-------|-------|-------|-------|--|--|
| Applied Motor       | Normal load          | HP          | 50  | 60   | 75    | 100   | 125   | 150   | 200   | 250   | 300   |  |  |
|                     |                      | kW          | 37  | 45   | 55    | 75    | 90    | 110   | 132   | 160   | 185   |  |  |
|                     | Heavy load           | HP          | 40  | 50   | 60    | 75    | 100   | 125   | 150   | 200   | 250   |  |  |
|                     |                      | kW          | 30  | 37   | 45    | 55    | 75    | 90    | 110   | 132   | 160   |  |  |
| Rated output        | Rated Capacity (kVA) |             | 46  | 57   | 69    | 84    | 116   | 139   | 170   | 201   | 248   |  |  |
|                     | Rated Current (A)    | Normal load | 75  | 91   | 110   | 152   | 183   | 223   | 264   | 325   | 370   |  |  |
|                     |                      | Heavy load  | 61  | 75   | 91    | 110   | 152   | 183   | 223   | 264   | 325   |  |  |
|                     | Output Frequency     |             | 0–400 Hz (Sensorless-1: 0–300 Hz, Sensorless-2, Vector: 0.1–120 Hz) |      |       |       |       |       |       |       |       |  |  |
|                     | Output Voltage (V)   |             | 3-Phase 380–480 V   |      |       |       |       |       |       |       |       |  |  |
| Rated input         | Working Voltage (V)  |             | 3-Phase 380–480 VAC (-15%–+10%)                                     |      |       |       |       |       |       |       |       |  |  |
|                     | Input Frequency      |             | 50–60 Hz (±5%)  |      |       |       |       |       |       |       |       |  |  |
|                     | Rated Current (A)    | Normal load | 67.5  | 81.7 | 101.8 | 143.6 | 173.4 | 212.9 | 254.2 | 315.3 | 359.3 |  |  |
|                     |                      | Heavy load  | 55.5  | 67.9 | 82.4  | 102.6 | 143.4 | 174.7 | 213.5 | 255.6 | 316.3 |  |  |

- The standard used for 400 V inverters is based on a 440 V supply voltage.
- The rated output current is limited based on the carrier frequency set at CON-04.
- The output frequency is limited to 0–300 Hz if DRV-09 (control mode) is set to “3 (Sensorless-1),” and to 0–120 Hz if DRV-09 (control mode) is set to “4 (Sensorless-3).”
- The maximum output voltage cannot exceed the input voltage of the power source.

## 2.5 Input and Output Specifications 400 V Class (185–375 kW)

| Model SV xxx iS7-4x |                      |             | 1850  | 2200 | 2800 | 3150 | 3750 |  |  |  |  |  |  |
|---------------------|----------------------|-------------|---|------|------|------|------|--|--|--|--|--|--|
| Applied Motor       | Normal load          | HP          | 350   | 400  | 500  | -    | -    |  |  |  |  |  |  |
|                     |                      | kW          | 220   | 280  | 315  | 375  | 450  |  |  |  |  |  |  |
|                     | Heavy load           | HP          | 300   | 350  | 400  | 500  | -    |  |  |  |  |  |  |
|                     |                      | kW          | 185   | 220  | 280  | 315  | 375  |  |  |  |  |  |  |
| Rated output        | Rated Capacity (kVA) |             | 286   | 329  | 416  | 467  | 557  |  |  |  |  |  |  |
|                     | Rated Current (A)    | Normal load | 432   | 547  | 613  | 731  | 877  |  |  |  |  |  |  |
|                     |                      | Heavy load  | 370   | 432  | 547  | 613  | 731  |  |  |  |  |  |  |
|                     | Output Frequency     |             | 0–400 Hz (Sensorless-1: 0–300 Hz, Sensorless-2, Vector: 0–120 Hz) |      |      |      |      |  |  |  |  |  |  |
|                     | Output Voltage (V)   |             | 3-Phase 380–480 V   |      |      |      |      |  |  |  |  |  |  |
| Rated input         | Working Voltage (V)  |             | 3-Phase 380–480 VAC (-15%–+10%)                                   |      |      |      |      |  |  |  |  |  |  |
|                     | Input Frequency      |             | 50–60 Hz (±5%)  |      |      |      |      |  |  |  |  |  |  |
|                     | Rated Current (A)    | Normal load | 463   | 590  | 673  | 796  | 948  |  |  |  |  |  |  |
|                     |                      | Heavy load  | 404   | 466  | 605  | 674  | 798  |  |  |  |  |  |  |

- The standard motor capacity is based on a standard 4-pole motor.
- The standard used for 400 V inverters is based on a 440 V supply voltage.
- The rated output current is limited based on the carrier frequency set at CON-04.
- The output frequency is limited to 0–300 Hz if DRV-09 (control mode) is set to “3 (Sensorless-1),” and to 0–120 Hz if DRV-09 (control mode) is set to “4 (Sensorless-3).”
- The maximum output voltage cannot exceed the input voltage of the power source.

### Note

[English]

The maximum allowed prospective short-circuit current at the input power connection is defined in IEC 60439-1 as 100 kA. The drive is suitable for use in a circuit capable of delivering not more than 100 kA RMS at the drive's maximum rated voltage, depending on the selected MCCB. RMS symmetrical amperes for recommended MCCB are the following table.

[French]

Le courant maximum de court-circuit présumé autorisé au connecteur d'alimentation électrique est défini dans la norme IEC 60439-1 comme égal à 100 kA. L'entraînement convient pour une utilisation dans un circuit capable de délivrer pas plus de 100 kA RMS à la tension nominale maximale de l'entraînement. Le tableau suivant indique le MCCB recommandé selon le courant RMS symétrique en ampères.

|                 |                 |                   |                   |                   |         |         |
|-----------------|-----------------|-------------------|-------------------|-------------------|---------|---------|
| Working Voltage | UTE100<br>(E/N) | UTS150<br>(N/H/L) | UTS250<br>(N/H/L) | UTS400<br>(N/H/L) |         |         |
| 240V(50/60Hz)   | 50/65kA         | 65/100/150kA      | 65/100/150kA      | 65/100/150kA      |         |         |
| 480V(50/60Hz)   | 25/35kA         | 35/65/100kA       | 35/65/100kA       | 35/65/100kA       |         |         |
| Working Voltage | ABS33c          | ABS53c            | ABS63c            | ABS103c           | ABS203c | ABS403c |
| 240V(50/60Hz)   | 30kA            | 35kA              | 35kA              | 85kA              | 85kA    | 75kA    |
| 480V(50/60Hz)   | 7.5kA           | 10kA              | 10kA              | 26kA              | 26kA    | 35kA    |

## 2.6 Product Specification Details

### 2.6.1 Control

| Items   |                               | Description   |
|---------|-------------------------------|---|
| Control | Control modes                 | V/F control, V/F PG, slip compensation, sensorless vector-1, sensorless vector-2, vector control                  |
|         | Frequency settings resolution | Digital command: 0.01 Hz<br>Analog command: 0.06 Hz (maximum frequency: 60 Hz)                                    |
|         | Frequency accuracy            | Digital command: 0.01% of maximum output frequency<br>Analog command: 0.1% of maximum output frequency            |
|         | V/F pattern                   | Linear, square reduction, user V/F  |
|         | Overload capacity             | Rated current for heavy duty operation: 150% for 1 min<br>Rated current for normal duty operation: 110% for 1 min |
|         | Torque boost                  | Manual torque boost, automatic torque boost   |

- Only the heavy load ratings apply to 0.75-22 kW model types without a built-in DC resistor (NON-DCR).

### 2.6.2 Operation

| Items                   |  | Description   |                         |             |  |   |  |
|-------------------------|--|---|-------------------------|-------------|--|---|--|
| Operation               | Operation types  | Select from keypad, terminal strip, or network communication operation.   |                         |             |  |   |  |
|                         | Frequency settings   | Analog type: -10~10 V, 0~10 V, 0~20 mA<br>Digital type: keypad  |                         |             |  |   |  |
|                         | Operation function   | <ul style="list-style-type: none"> <li>• PID control</li> <li>• 3-wire operation</li> <li>• Frequency limit</li> <li>• Second function</li> <li>• Reverse rotation prevention</li> <li>• Inverter bypass</li> <li>• Flying start</li> <li>• Power braking</li> <li>• Leakage reduction</li> <li>• Easy start</li> <li>• Up-down operation</li> <li>• DC braking</li> <li>• Frequency jump</li> <li>• Slip compensation</li> <li>• Automatic restart</li> <li>• Automatic tuning</li> <li>• Energy buffering</li> <li>• Flux braking</li> <li>• MMC</li> </ul> |                         |             |  |   |  |
|                         | Input  | <table border="1" style="width: 100%; border-collapse: collapse;"> <thead> <tr> <th>Multi-function terminal</th> <th>Description</th> </tr> </thead> <tbody> <tr> <td></td> <td>Select NPN (Sink) or PNP (Source) mode.</td> </tr> <tr> <td></td> <td> <ul style="list-style-type: none"> <li>• Forward direction operation</li> <li>• Reverse direction</li> </ul> </td> </tr> </tbody> </table>   | Multi-function terminal | Description |  | Select NPN (Sink) or PNP (Source) mode. |  |
| Multi-function terminal | Description  |   |                         |             |  |   |  |
|                         | Select NPN (Sink) or PNP (Source) mode.  |   |                         |             |  |   |  |
|                         | <ul style="list-style-type: none"> <li>• Forward direction operation</li> <li>• Reverse direction</li> </ul> |   |                         |             |  |   |  |

| Items  |  | Description  |
|--------|--|--|
|        | (8 EA)<br>P1–P8*                       | <ul style="list-style-type: none"> <li>Reset operation</li> <li>Emergency stop</li> <li>Multi-step speed frequency-high/med/low</li> <li>DC braking during stop</li> <li>Frequency increase</li> <li>3-wire operation</li> <li>Acceleration/deceleration/stop</li> <li>Operation by keypad input during an operation by network communication</li> <li>External trip</li> <li>Jog operation</li> <li>Multi-step acc/dec-high/med/low</li> <li>Second motor selection</li> <li>Frequency reduction</li> <li>Transition from PID to general operation</li> <li>Analog command frequency fix</li> </ul> |
| Output | Multi-function open collector terminal | Fault output and inverter operation status output  |
|        | Multi-function relay terminal          |  |
|        | Analog output                          | DC 0–10 V, 0–20 mA: Select output type from frequency, current, voltage, or DC voltage.  |
|        |  | Less than DC 26 V, 100 mA  |
|        |  | N.O.: Less than AC 250 V 1A, DC 30 V, 3A<br>N.C.: Less than AC 250 V 1A, DC 30 V 1A  |

\* Set the Input Group codes IN-65 through IN-72 to configure the multi-function terminal functions.

### 2.6.3 Protection Function

| Items               |                        | Description   |
|---------------------|------------------------|---|
| Protection function | Trips                  | <ul style="list-style-type: none"> <li>• Over voltage</li> <li>• Low voltage</li> <li>• Over current</li> <li>• Earth current detection</li> <li>• Inverter overheat</li> <li>• Motor overheat</li> <li>• Output imaging</li> <li>• Overload protection</li> <li>• Network communication error</li> <li>• Lost command</li> <li>• Hardware failure</li> <li>• Cooling fan failure</li> <li>• Pre-PID failure</li> <li>• No motor trip</li> <li>• External trip</li> <li>• Other safety functions</li> </ul> |
|                     | Alarms                 | <ul style="list-style-type: none"> <li>• Stall prevention</li> <li>• Overload</li> <li>• Light load</li> <li>• Encoder error</li> <li>• Fan failure</li> <li>• Keypad command loss</li> <li>• Speed command loss</li> </ul>   |
|                     | Instantaneous blackout | <p>Less than 15 ms (CT) [Less than 8 ms (VT)]: Continue operation (must be within the rated input voltage and rated output range).<br/>                     Over 15 ms (CT) [Over 8 ms (VT)]: Automatically restart</p>   |

### 2.6.4 Structure and Operating Environment Control

| Items                               |                      | Description   |
|-------------------------------------|----------------------|---|
| Structure/<br>operating environment | Cooling type         | <p>Forced cooling: 0.75–15 kW (200/400 V class), 22 kW (400 V class)<br/>                     Inhalation cooling: 22–75 kW (200 V class), 30–375 kW (400 V class)</p>   |
|                                     | Protection structure | <p>- 0.75–22 kW (200V), 0.75–75 kW (400 V): Open type IP 21 (default), UL enclosed type 1 (optional)*<br/>                     - 30–75 kW (200 V), 90–375 kW (400 V): Open type IP 00<br/>                     - 0.75–22 kW, frame types 2, 4 and others.: Enclosed IP54 type, UL enclosed type 12</p>  |
|                                     | Ambient temperature  | <ul style="list-style-type: none"> <li>• CT load (heavy duty): -10–50°C</li> <li>• VT load (normal duty): -10–40°C</li> <li>- No ice or frost should be present.</li> <li>- Working under normal load at 50°C (122°F), it is recommended that less than 80% load is applied.</li> <li>• IP54 product: -10–40°C</li> <li>- No ice or frost should be present.</li> </ul> |



## Technical Specifications

| Items |                         | Description   |
|-------|-------------------------|---|
|       | Storage temperature.    | -20°C–65°C (-4–149°F)   |
|       | Ambient humidity        | Relative humidity less than 95% RH (to prevent condensation from forming)   |
|       | Operation altitude      | Maximum 1000m above sea level for standard operation. From 1000 to 4000m, the rated input voltage and rated output current of the drive must be derated by 1% for every 100m. |
|       | Oscillation             | Less than 5.9 m/sec <sup>2</sup> (0.6 G).   |
|       | Surrounding environment | Prevent contact with corrosive gases, inflammable gases, oil stains, dust, and other pollutants (Pollution Degree 2 Environment).   |

\* UL Enclosed type 1 when an optional conduit box is installed. The 30–75 kW (200 V class) product is regarded as UL Open type IP 20 when an optional conduit box is installed.

## 3 Installing the Inverter

### 3.1 Installation Considerations

Inverters are composed of various precision electronic devices, and therefore the installation environment can significantly impact the lifespan and reliability of the product. The table below details the ideal operation and installation conditions for the inverter.

| Items                 | Description   |
|-----------------------|---|
| Ambient Temperature*  | CT load (heavy duty): -10°C–50°C<br>VT load (normal duty): -10°C–40°C<br>IP54 model types: -10°C–40°C |
| Ambient Humidity      | 90% relative humidity (no condensation)   |
| Storage Temperature   | - 4–149°F (-20–65°C)  |
| Environmental Factors | An environment free from corrosive or flammable gases, oil residue, or dust (pollution degree 2)      |
| Altitude/Vibration    | Lower than 3,280 ft (1,000 m) above sea level/less than 0.6 G (5.9 m/sec <sup>2</sup> )               |
| Air Pressure          | 70–106 kPa  |

\*The ambient temperature is the temperature measured at a point 2" (5 cm) from the surface of the inverter. No ice or frost should be present.

#### ⓘ Caution

- Do not transport the inverter by lifting with the inverter's covers or plastic surfaces. The inverter may tip over if covers break, causing injuries or damage to the product. Always support the inverter using the metal frames when moving it.
- Hi-capacity inverters are very heavy and bulky. Use an appropriate transport method that is suitable for the weight. Do not place heavy objects on top of electric cables. Doing so may damage the cable and result in an electric shock.
- Do not install the inverter on the floor or mount it sideways against a wall. The inverter must be installed vertically, on a wall or inside a panel, with its rear flat on the mounting surface.

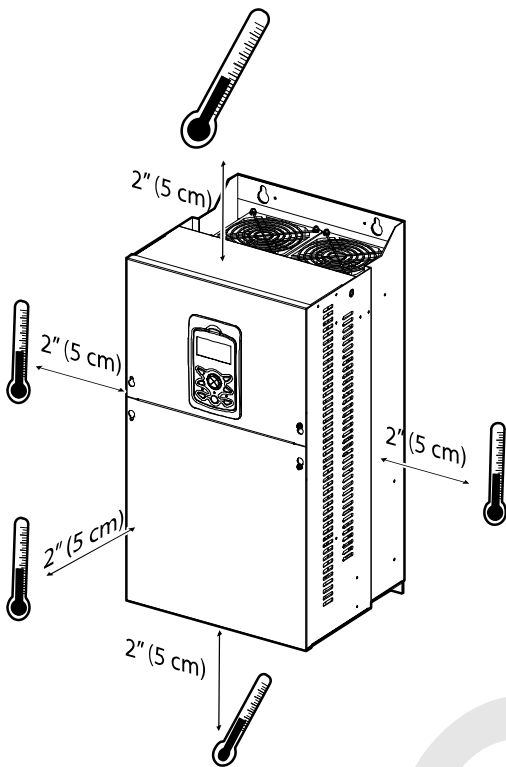

### ⚠ Caution

Do not allow the ambient temperature to exceed the allowable range while operating the inverter.

## 3.2 Selecting and Preparing a Site for Installation

When selecting an installation location, consider the following requirements:

- The inverter must be installed on a wall that can support the inverter's weight.
- The location must be free from vibration. Vibrations can adversely affect the operation of the inverter.
- The inverter can become very hot during operation. Install the inverter on a surface that is fire resistant or flame retardant with sufficient clearance around the inverter to allow for air circulation. The illustrations below detail the required installation clearances.

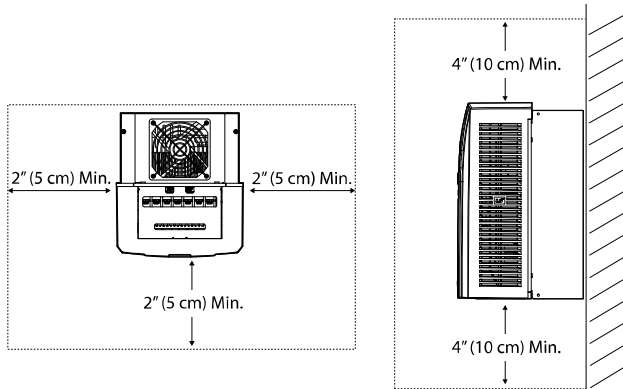

<Clearance requirements for model types with less than 30 kW capacity>

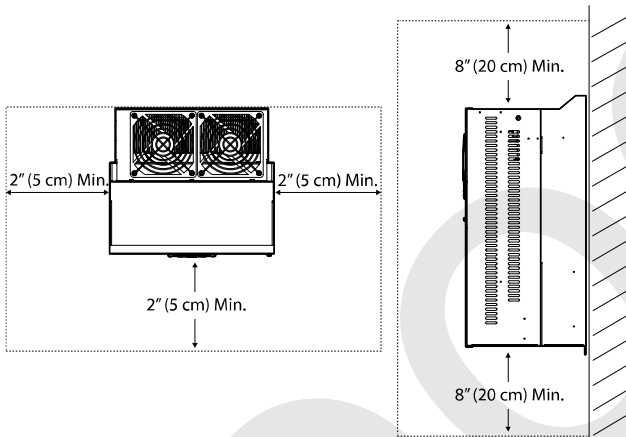

<Clearance requirements for model types with more than 30 kW capacity>

## ⚠ Caution

Install the inverter on a non-flammable surface, and do not place flammable material near the inverter. Otherwise, a fire may result.

## Note

Model types with capacities of 30 kW or more require a minimum of 8" clearance above and below the unit.

## Installing the Inverter

- Ensure that the cable conduits do not obstruct the air flow to and from the cooling fan.

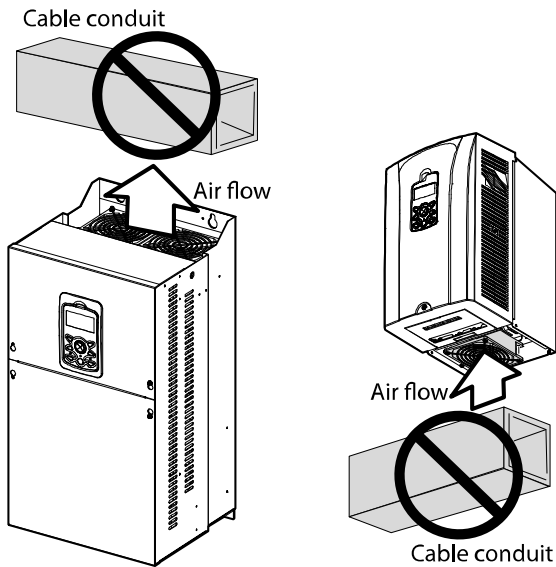

- Ensure sufficient air circulation is provided around the inverter when it is installed. If the inverter is to be installed inside a panel, enclosure, or cabinet rack, carefully consider the position of the inverter's cooling fan and vents. The cooling fan must be positioned to efficiently dissipate the heat generated by the operation of the inverter.

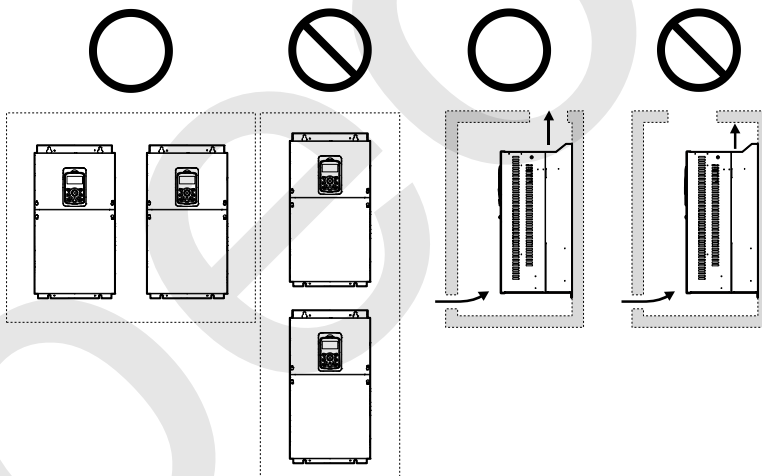

### Note

In order to meet EMC standards, 200 V, 30–75 kW model types and model types with capacities of 90 kW or more should be installed inside a metal cabinet.

- If you are installing multiple inverters of different ratings, provide sufficient clearance to meet the clearance specifications of the larger inverter. The iS7 inverters rated for up to 30 kW may be installed side by side.

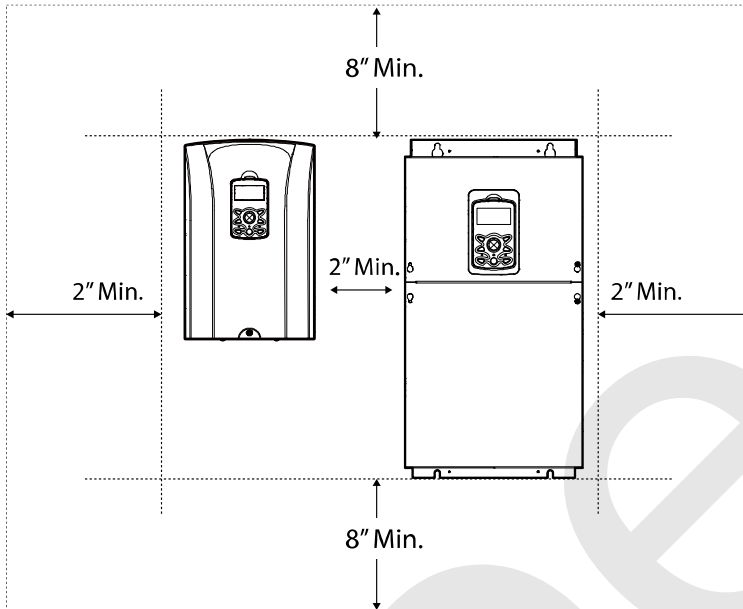

### 3.3 Exterior and Dimensions (UL Enclosed Type 1, IP21 Type)

SV0008-0037iS7 (200 V/400 V)

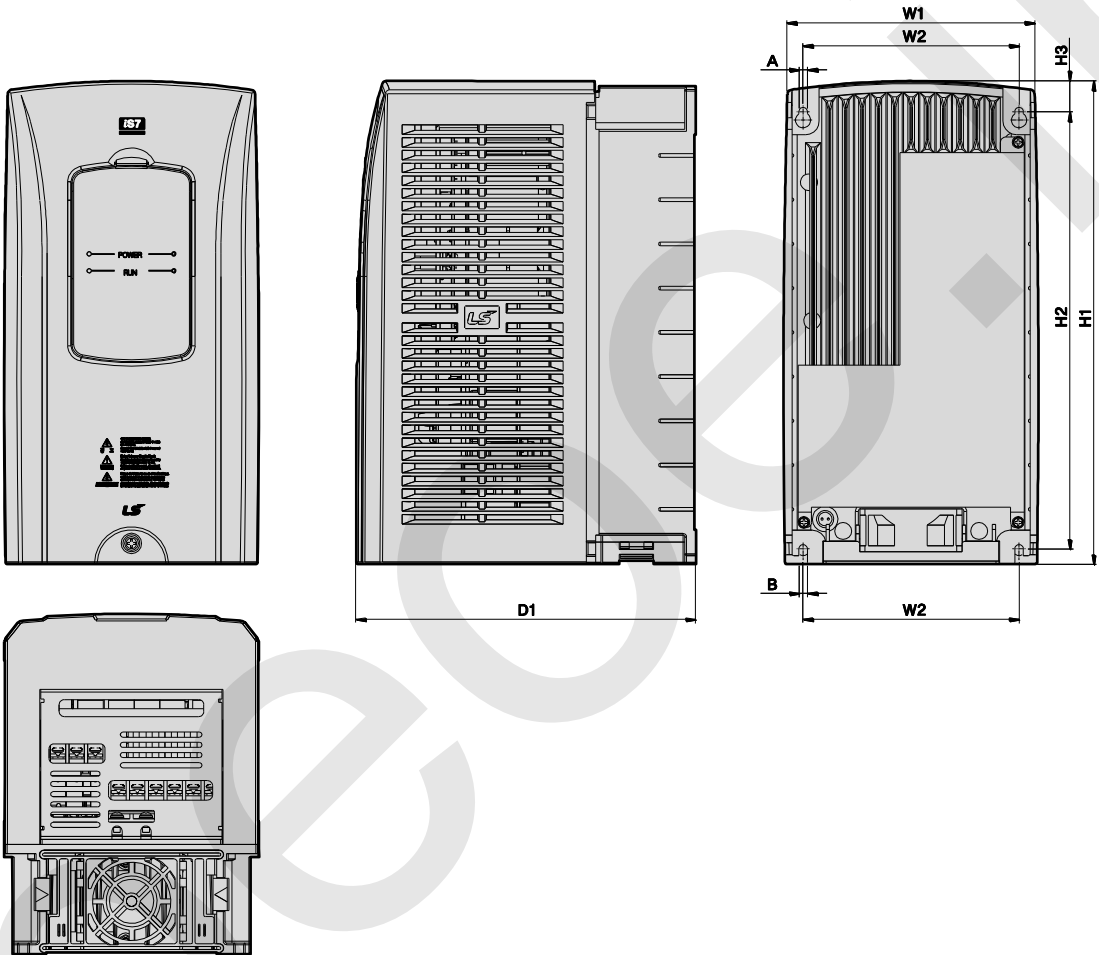

Units: mm (inch)

| Inverter Capacity     | W1            | W2            | H1             | H2             | H3           | D1            | A           | B           |
|-----------------------|---------------|---------------|----------------|----------------|--------------|---------------|-------------|-------------|
| SV0008-0037 iS7 - 2/4 | 150<br>(5.90) | 127<br>(5.00) | 284<br>(11.18) | 257<br>(10.11) | 18<br>(0.70) | 200<br>(7.87) | 5<br>(0.19) | 5<br>(0.19) |

SV0055-0075iS7 (200 V/400 V)

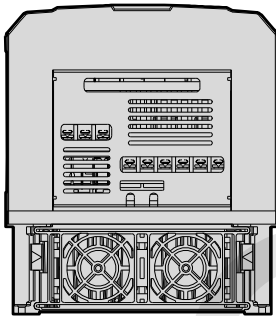
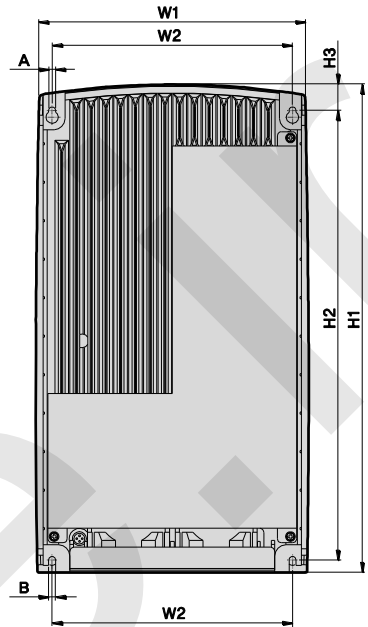
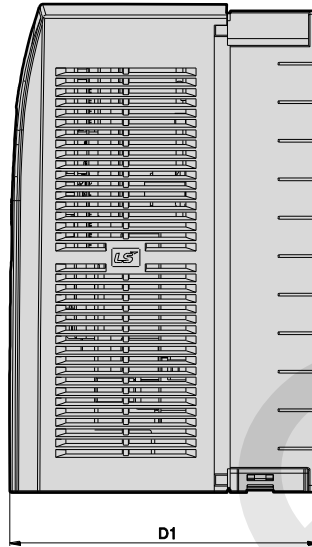
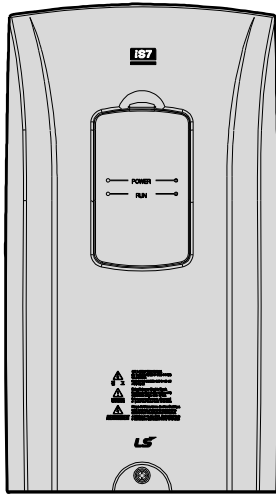

Installing  
the Inverter

Units: mm (inch)

| Inverter Capacity     | W1            | W2            | H1             | H2             | H3           | D1            | A           | B           |
|-----------------------|---------------|---------------|----------------|----------------|--------------|---------------|-------------|-------------|
| SV0055-0075 iS7 - 2/4 | 200<br>(7.87) | 176<br>(6.92) | 355<br>(13.97) | 327<br>(12.87) | 19<br>(0.74) | 225<br>(8.85) | 5<br>(0.19) | 5<br>(0.19) |

SV0110-0150iS7 (200 V/400 V)



# Installing the Inverter

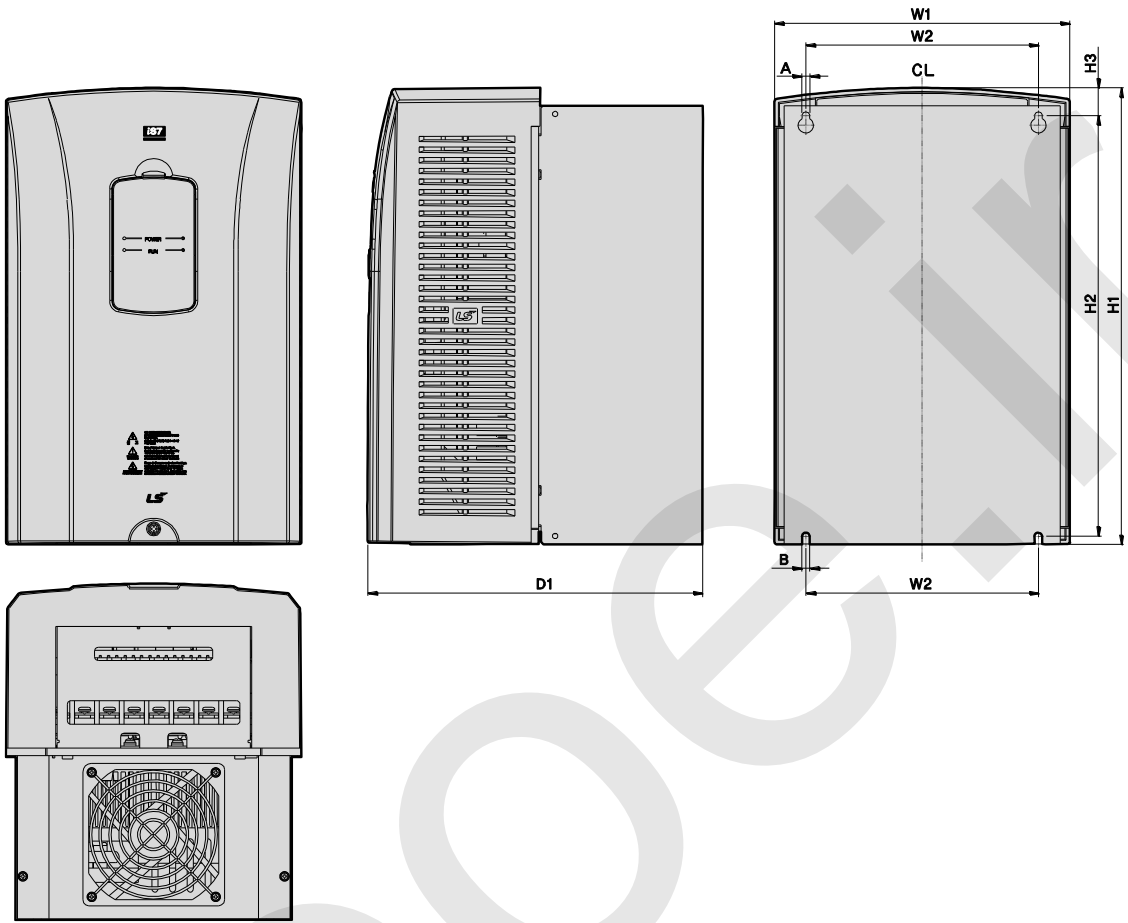

Units: mm (inch)

| Inverter Capacity    | W1            | W2              | H1             | H2             | H3             | D1             | A             | B             |
|----------------------|---------------|-----------------|----------------|----------------|----------------|----------------|---------------|---------------|
| SV0110-0150 iS7- 2/4 | 250<br>(9.84) | 214.6<br>(8.44) | 385<br>(15.15) | 355<br>(13.97) | 23.6<br>(0.92) | 284<br>(11.18) | 6.5<br>(0.25) | 6.5<br>(0.25) |

SV0185-0220iS7 (200 V/400 V)

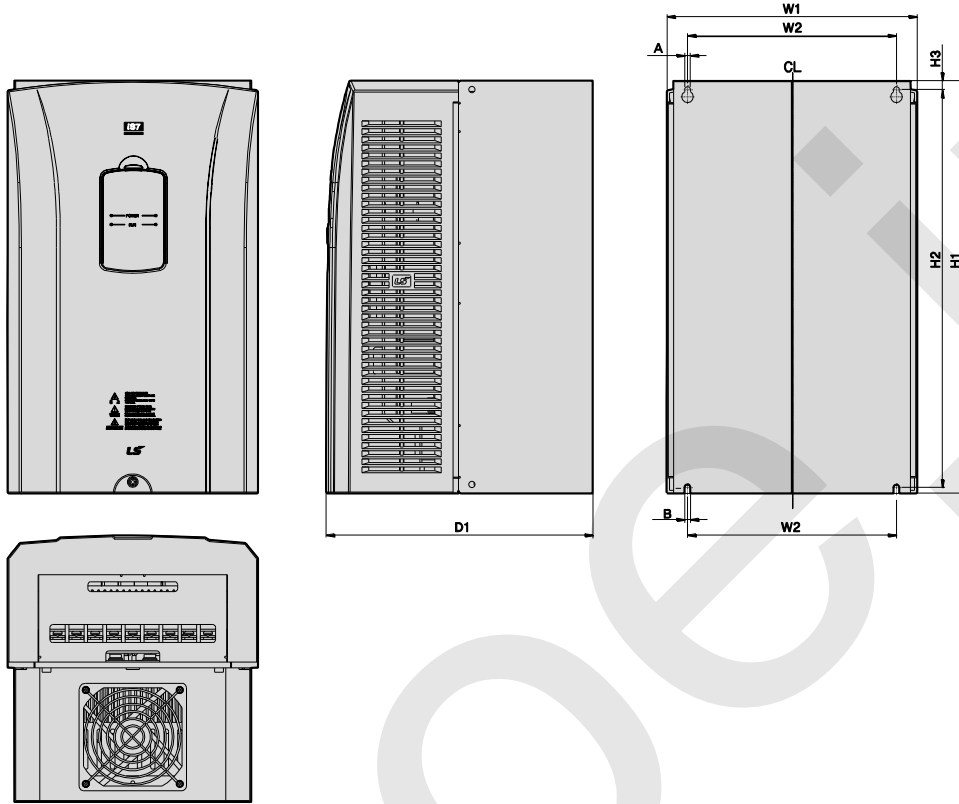

Installing  
the Inverter

Units: mm (inch)

| Inverter Capacity   | W1             | W2              | H1               | H2             | H3             | D1             | A             | B             |
|---------------------|----------------|-----------------|------------------|----------------|----------------|----------------|---------------|---------------|
| SV0185-0220iS7- 2/4 | 280<br>(11.02) | 243.5<br>(9.58) | 461.6<br>(18.17) | 445<br>(17.51) | 10.1<br>(0.39) | 298<br>(11.73) | 6.5<br>(0.25) | 6.5<br>(0.25) |

## SV0300-iS7 (200 V, IP00 Type)

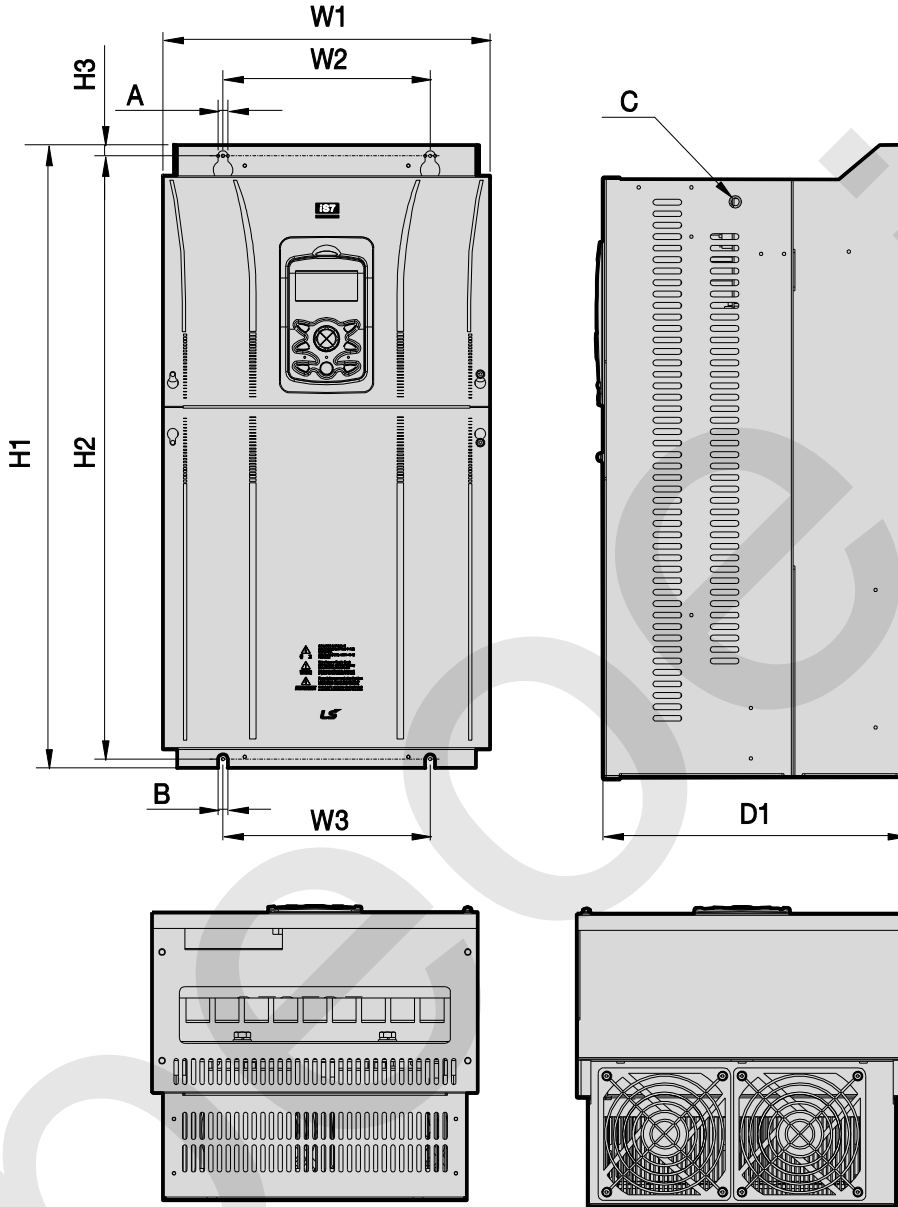

Units: mm (inch)

| Inverter Capacity | W1             | W2            | W3            | H1             | H2             | H3           | D1               | A            | B            | C  |
|-------------------|----------------|---------------|---------------|----------------|----------------|--------------|------------------|--------------|--------------|----|
| SV0300 iS7-2      | 300<br>(11.81) | 190<br>(7.48) | 190<br>(7.48) | 570<br>(22.44) | 552<br>(21.73) | 10<br>(0.39) | 265.2<br>(10.44) | 10<br>(0.39) | 10<br>(0.39) | M8 |

SV0370-0450iS7 (200 V, IP00 Type)

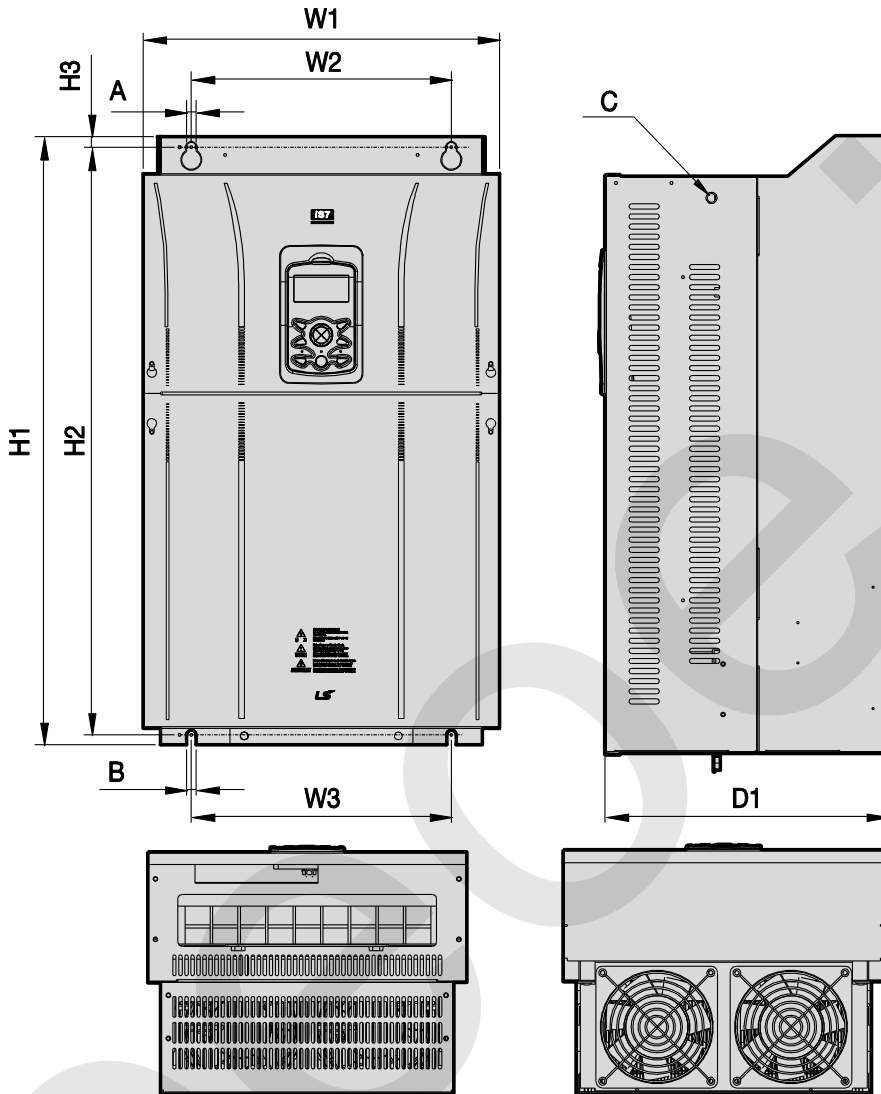

Units: mm (inch)

| Inverter Capacity    | W1             | W2             | W3             | H1            | H2             | H3           | D1               | A            | B            | C   |
|----------------------|----------------|----------------|----------------|---------------|----------------|--------------|------------------|--------------|--------------|-----|
| SV0370-0450<br>iS7-2 | 370<br>(14.56) | 270<br>(10.63) | 270<br>(10.63) | 630<br>(24.8) | 609<br>(23.97) | 11<br>(0.43) | 281.2<br>(11.07) | 10<br>(0.39) | 10<br>(0.39) | M10 |

Installing  
the Inverter

## SV0300-0450iS7 (400 V)

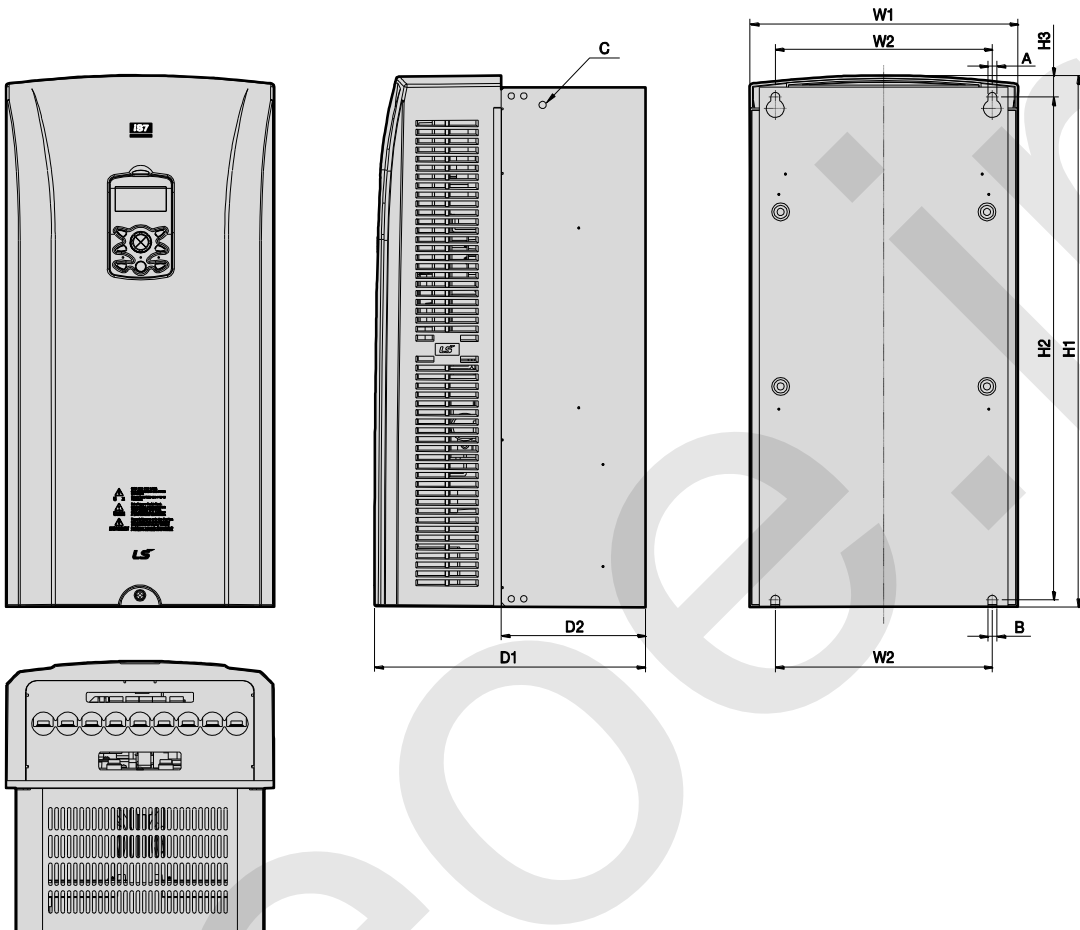

Units: mm (inch)

| Inverter Capacity  | W1               | W2              | H1               | H2             | H3             | D1               | D2            | A            | B            | C  |
|--------------------|------------------|-----------------|------------------|----------------|----------------|------------------|---------------|--------------|--------------|----|
| SV300-450<br>iS7-4 | 300.1<br>(11.81) | 242.8<br>(9.55) | 594.1<br>(23.38) | 562<br>(22.12) | 24.1<br>(0.94) | DCR type         |               | 10<br>(0.39) | 10<br>(0.39) | M8 |
|                    |                  |                 |                  |                |                | 303.2<br>(11.93) | 161<br>(6.33) |              |              |    |
|                    |                  |                 |                  |                |                | Non-DCR type     |               |              |              |    |
|                    |                  |                 |                  |                |                | 271.2<br>(10.67) | 129<br>(5.78) |              |              |    |

SV0550-0750iS7 (200 V, IP00 Type)

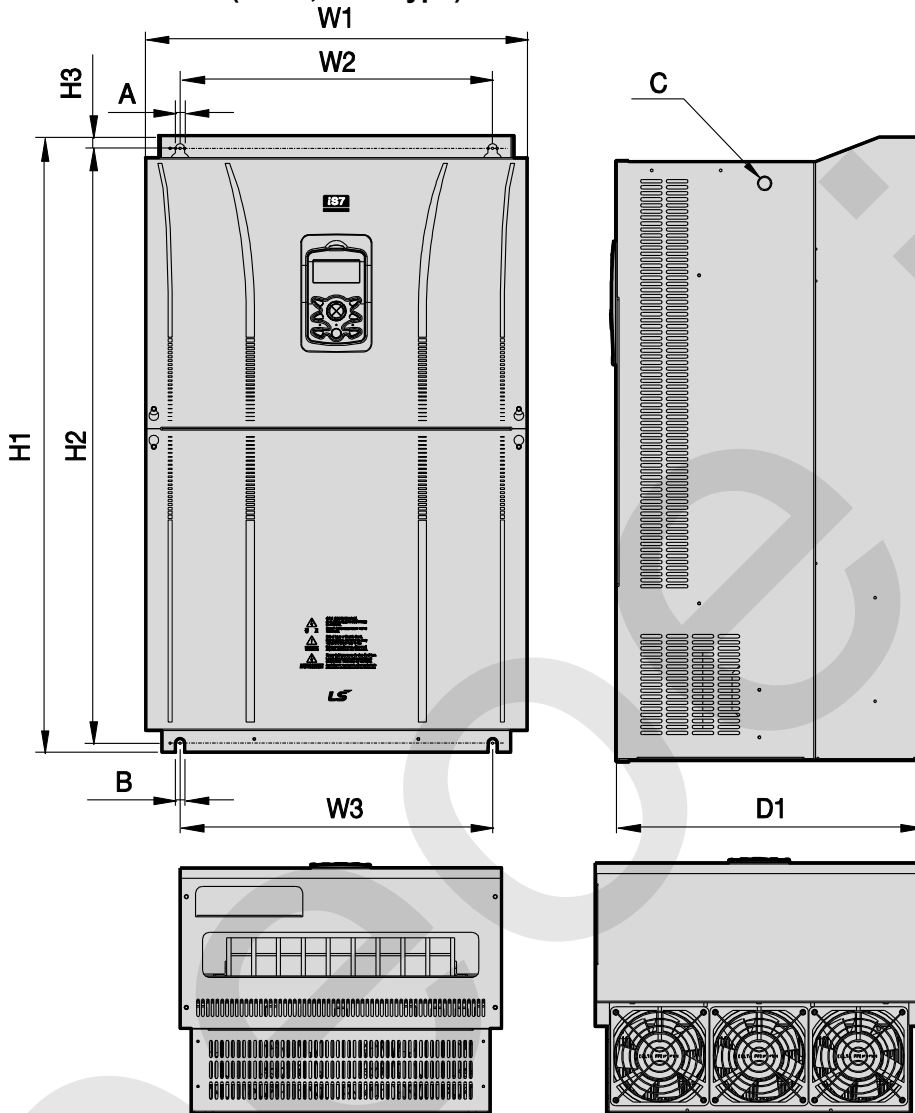

Installing  
the Inverter

Units: mm (inch)

| Inverter Capacity    | W1            | W2            | W3            | H1             | H2               | H3             | D1              | A            | B            | C   |
|----------------------|---------------|---------------|---------------|----------------|------------------|----------------|-----------------|--------------|--------------|-----|
| SV0550-0750<br>iS7-2 | 465<br>(18.3) | 381<br>(15.0) | 381<br>(15.0) | 750<br>(29.52) | 723.5<br>(28.48) | 15.5<br>(0.61) | 355.6<br>(14.0) | 11<br>(0.43) | 11<br>(0.43) | M16 |

## SV0550-0750iS7 (400 V)

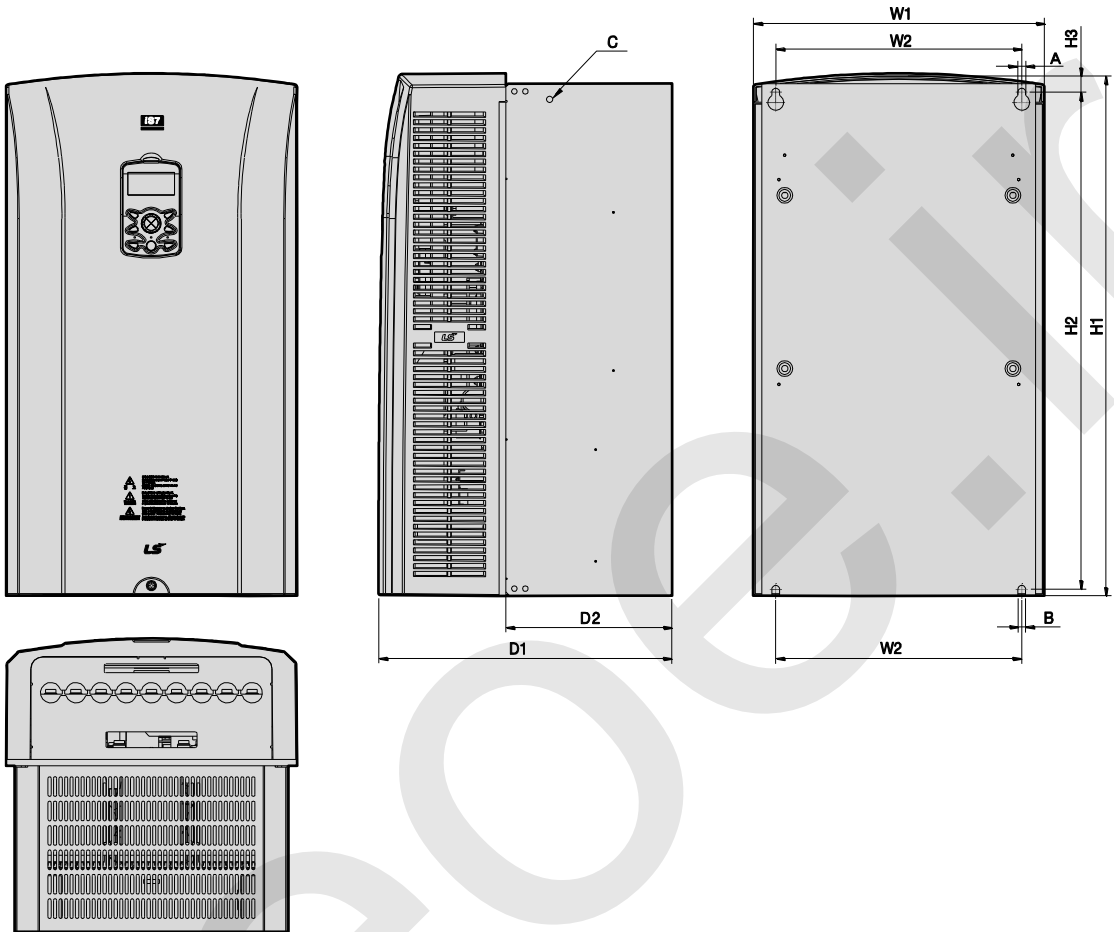

Units: mm (inch)

| Inverter Capacity    | W1               | W2               | H1               | H2               | H3             | D1               | D2              | A            | B            | C  |
|----------------------|------------------|------------------|------------------|------------------|----------------|------------------|-----------------|--------------|--------------|----|
| SV0550-0750<br>iS7-4 | 370.1<br>(14.57) | 312.8<br>(12.31) | 663.5<br>(26.12) | 631.4<br>(24.85) | 24.1<br>(0.94) | DCR type         |                 | 10<br>(0.39) | 10<br>(0.39) | M8 |
|                      |                  |                  |                  |                  |                | 373.3<br>(14.69) | 211.5<br>(8.32) |              |              |    |
|                      |                  |                  |                  |                  |                | Non-DCR type     |                 |              |              |    |
|                      |                  |                  |                  |                  |                | 312.4<br>(12.29) | 150.6<br>(5.92) |              |              |    |

SV0900-1100iS7 (400 V, IP00 Type)

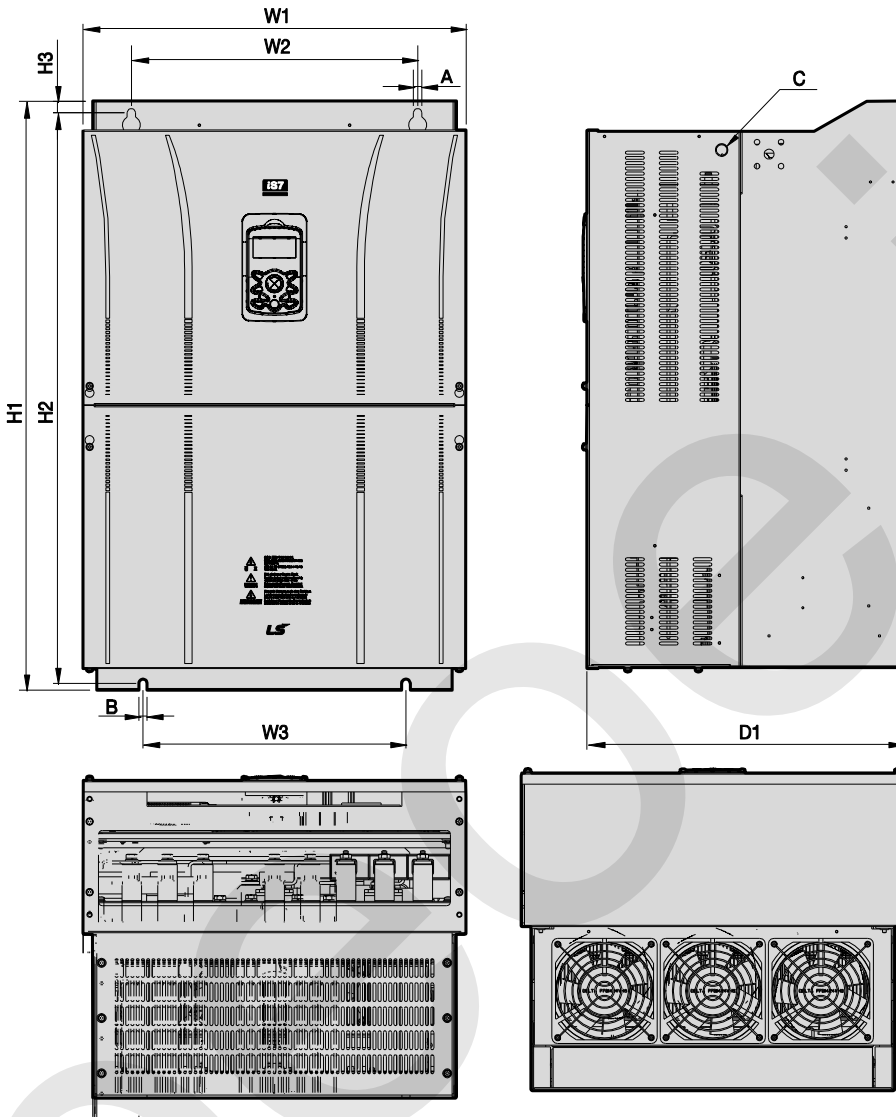

Installing  
the Inverter

Units: mm (inch)

| Inverter Capacity    | W1             | W2            | W3             | H1               | H2             | H3             | D1               | A            | B            | C   |
|----------------------|----------------|---------------|----------------|------------------|----------------|----------------|------------------|--------------|--------------|-----|
| SV0900-1100<br>iS7-4 | 510<br>(20.07) | 381<br>(15.0) | 350<br>(13.77) | 783.5<br>(30.84) | 759<br>(29.88) | 15.5<br>(0.61) | 422.6<br>(16.63) | 11<br>(0.43) | 11<br>(0.43) | M16 |



# Installing the Inverter

## SV1320-1600iS7 (400 V, IP00 Type)

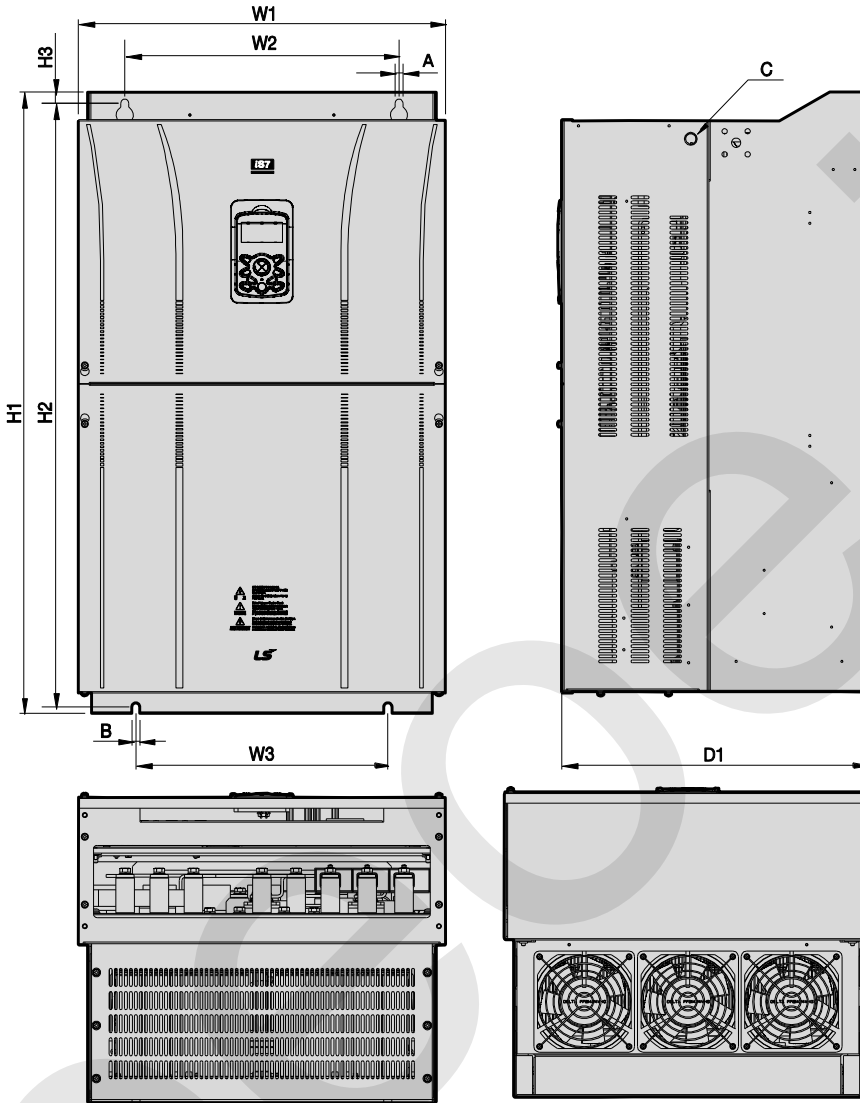

Units: mm (inch)

| Inverter Capacity    | W1             | W2            | W3             | H1             | H2               | H3             | D1               | A            | B            | C   |
|----------------------|----------------|---------------|----------------|----------------|------------------|----------------|------------------|--------------|--------------|-----|
| SV1320-1600<br>iS7-4 | 510<br>(20.07) | 381<br>(15.0) | 350<br>(13.77) | 861<br>(33.89) | 836.5<br>(32.93) | 15.5<br>(0.61) | 422.6<br>(16.63) | 11<br>(0.43) | 11<br>(0.43) | M16 |

SV1850-2200iS7 (400 V, IP00 Type)

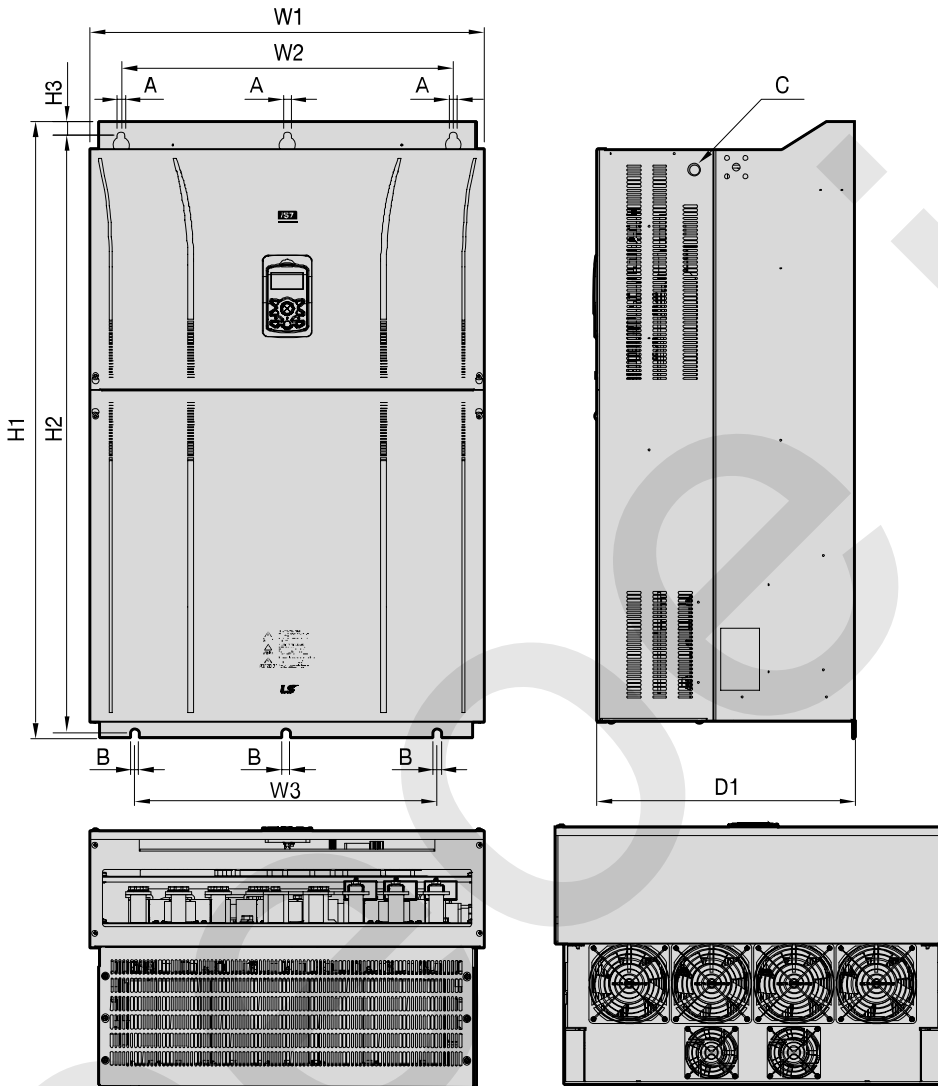

Installing  
the Inverter

Units: mm (inch)

| Inverter Capacity    | W1             | W2             | W3             | H1              | H2                | H3             | D1             | A            | B            | C   |
|----------------------|----------------|----------------|----------------|-----------------|-------------------|----------------|----------------|--------------|--------------|-----|
| SV1850/<br>2200iS7-4 | 690<br>(27.16) | 581<br>(22.87) | 528<br>(20.79) | 1078<br>(42.44) | 1043.5<br>(41.08) | 25.5<br>(1.00) | 450<br>(17.72) | 14<br>(0.55) | 15<br>(0.59) | M20 |

## SV2800iS7 (400 V, IP00 Type)

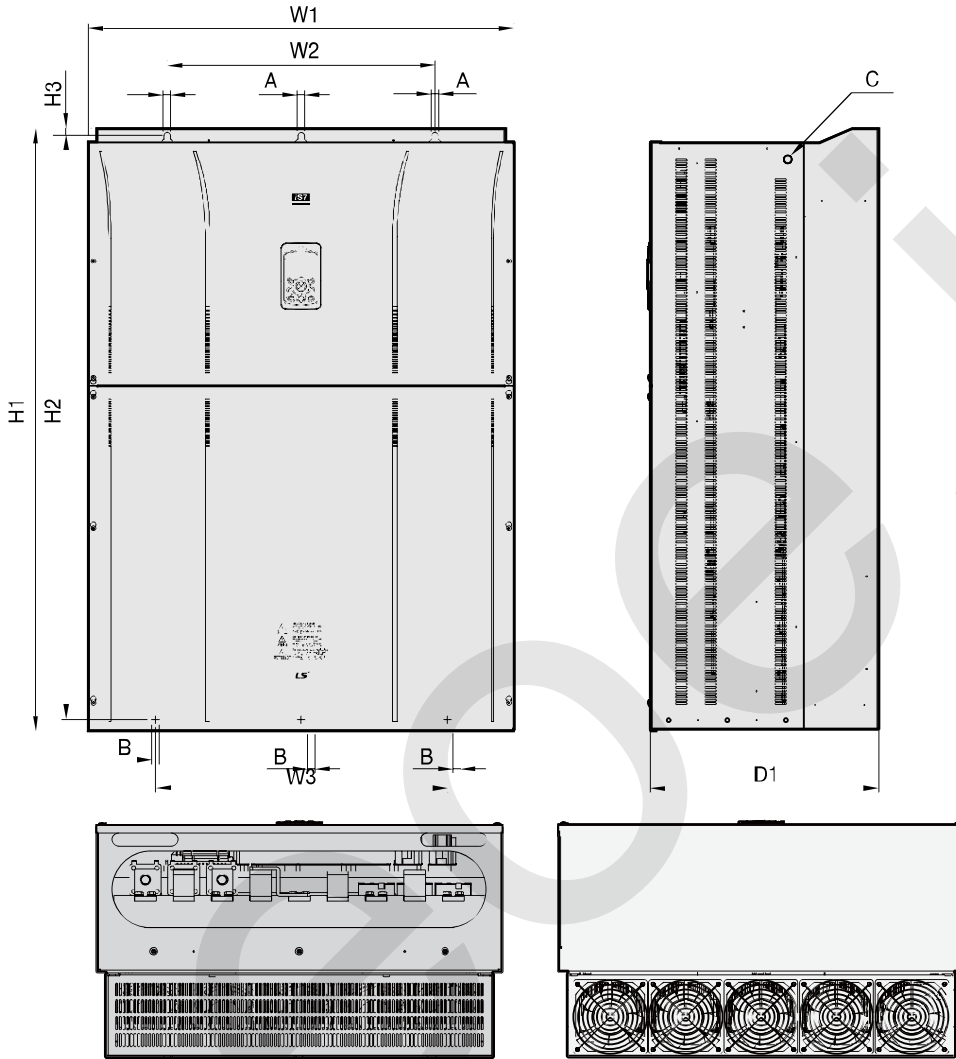

Units: mm (inch)

| Inverter Capacity | W1             | W2             | W3             | H1              | H2              | H3           | D1             | A            | B            | C   |
|-------------------|----------------|----------------|----------------|-----------------|-----------------|--------------|----------------|--------------|--------------|-----|
| SV2800iS7-4       | 771<br>(30.35) | 500<br>(19.69) | 500<br>(19.69) | 1138<br>(44.80) | 1110<br>(43.70) | 15<br>(0.59) | 440<br>(17.32) | 13<br>(0.51) | 13<br>(0.51) | M16 |

For 280 kW model types, 1 volts are supplied with the product.

## SV3150-3750iS7 (400 V, IP00 Type)

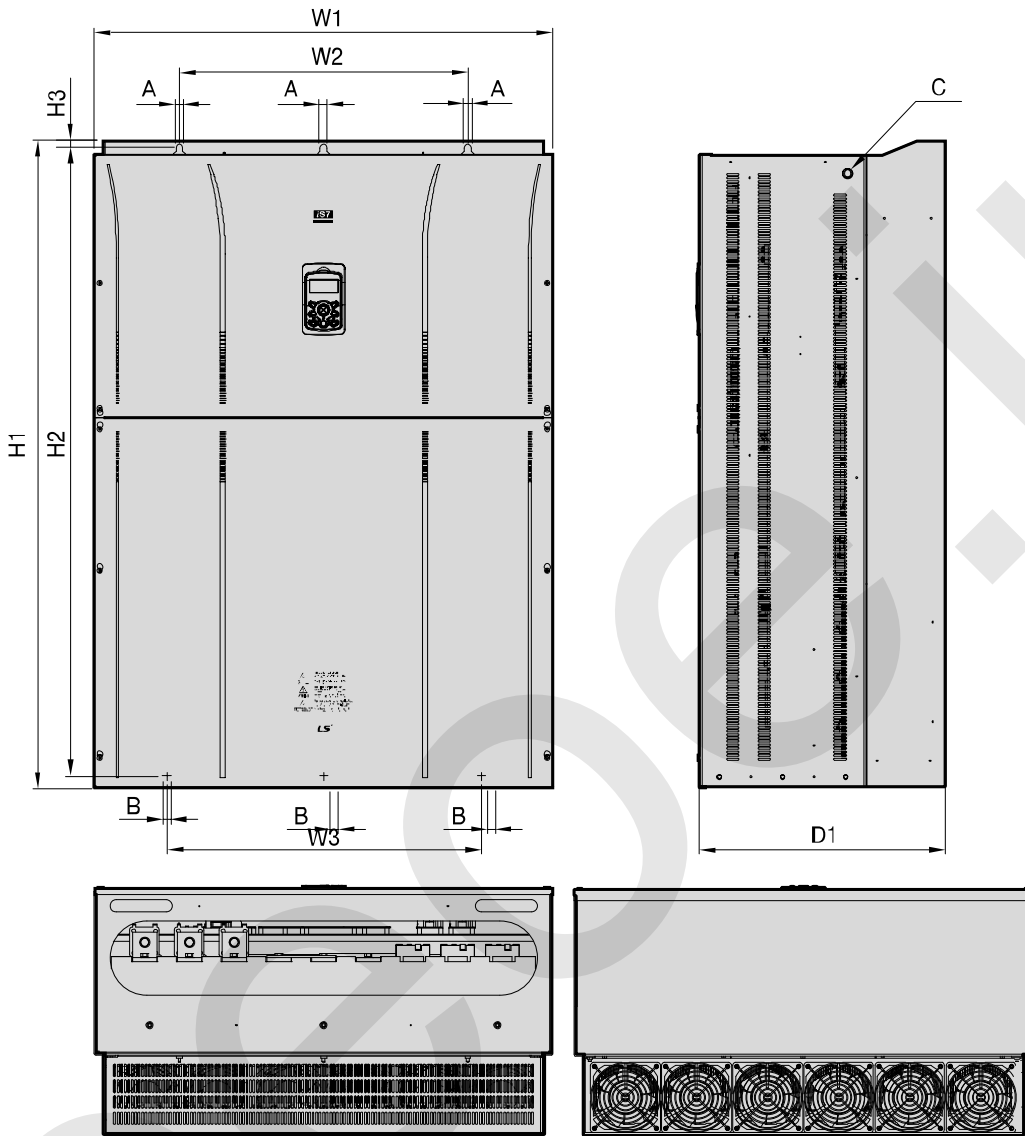

Units: mm (inch)

| Inverter Capacity    | W1             | W2             | W3             | H1                | H2                | H3           | D1             | A            | B            | C   |
|----------------------|----------------|----------------|----------------|-------------------|-------------------|--------------|----------------|--------------|--------------|-----|
| SV3150/<br>3750iS7-4 | 922<br>(36.30) | 580<br>(22.83) | 580<br>(22.83) | 1302.5<br>(51.28) | 1271.5<br>(50.06) | 15<br>(0.59) | 495<br>(19.49) | 14<br>(0.55) | 14<br>(0.55) | M16 |

For 315-375 kW model types, I volts are supplied with the product.

### 3.4 Exterior and Dimensions (UL Enclosed Type 12, IP54 Type)

SV0008-0037iS7 (200 V/400 V)

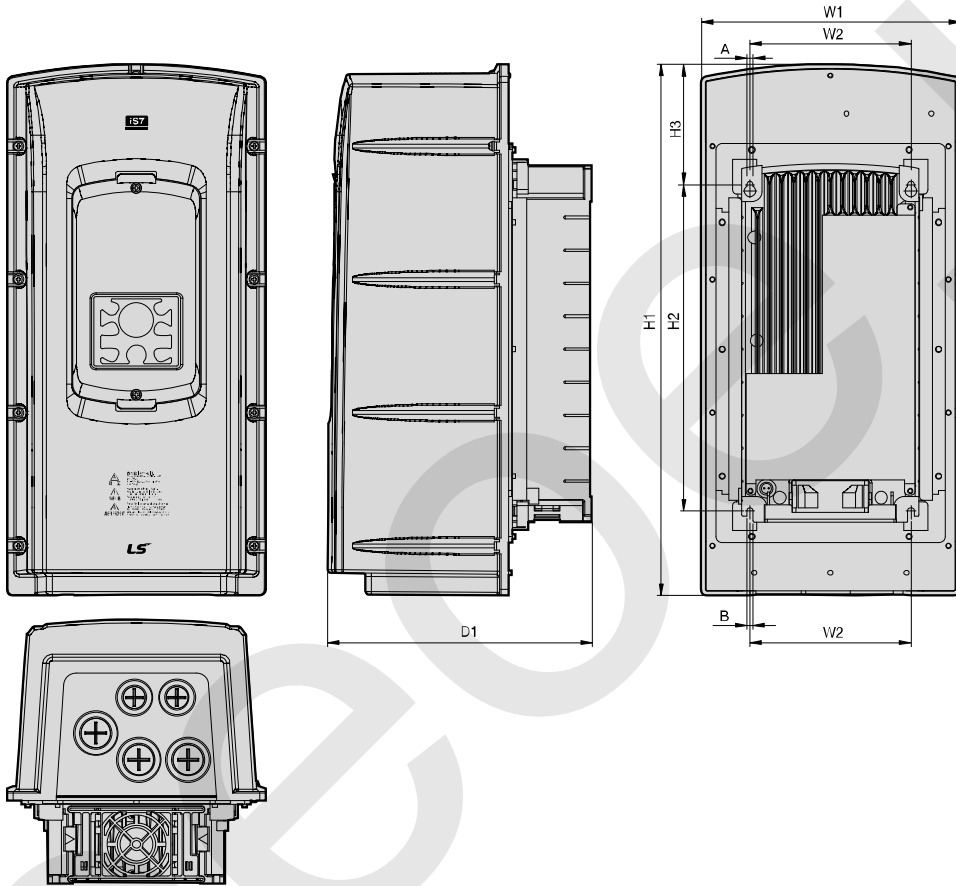

Units: mm (inch)

| Inverter Capacity   | W1              | W2           | H1             | H2             | H3             | D1            | A           | B           |
|---------------------|-----------------|--------------|----------------|----------------|----------------|---------------|-------------|-------------|
| SV0008-0037 iS7-2/4 | 204.2<br>(8.03) | 127<br>(5.0) | 419<br>(16.49) | 257<br>(10.11) | 95.1<br>(3.74) | 208<br>(8.18) | 5<br>(0.19) | 5<br>(0.19) |

SV0055-0075iS7 (200 V/400 V)

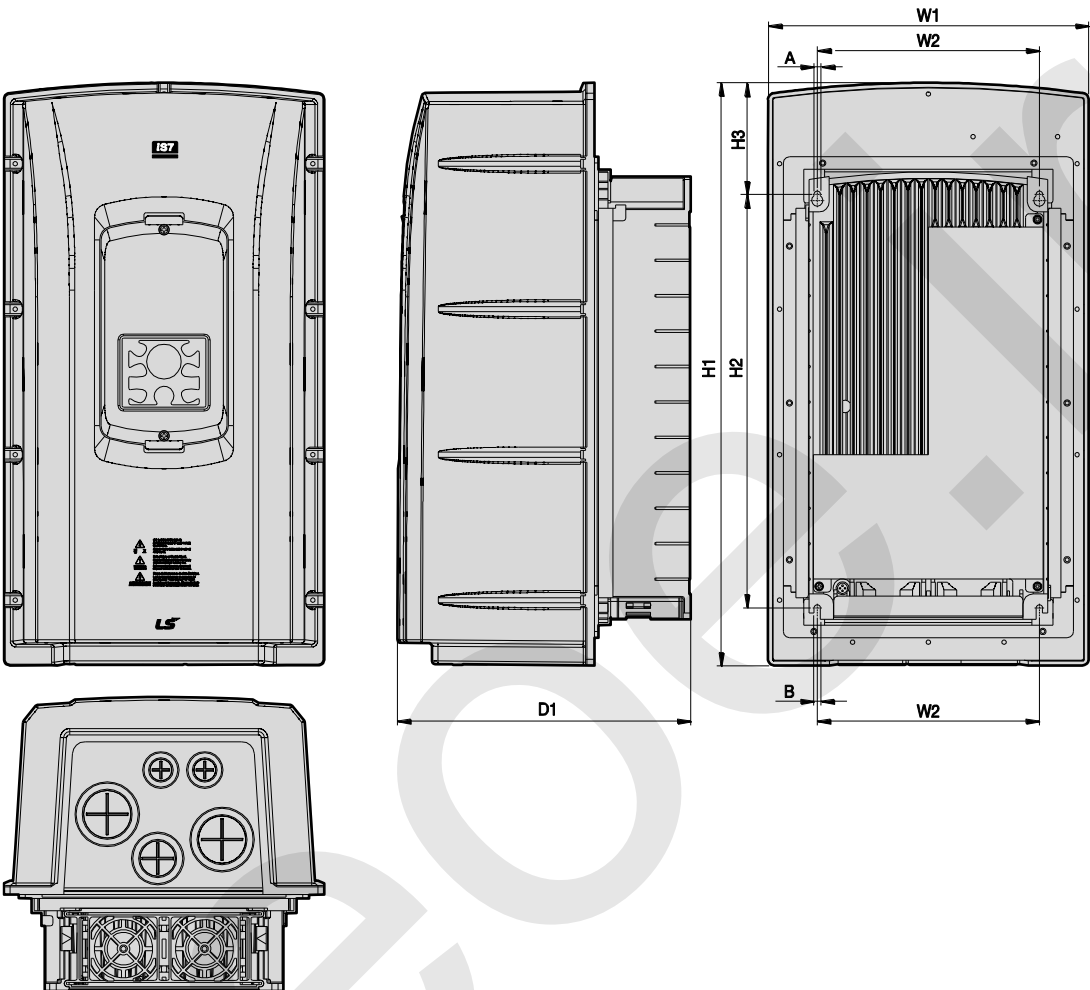

Units: mm (inch)

| Inverter Capacity   | W1            | W2            | H1               | H2             | H3             | D1              | A           | B           |
|---------------------|---------------|---------------|------------------|----------------|----------------|-----------------|-------------|-------------|
| SV0055-0075 iS7-2/4 | 254<br>(10.0) | 176<br>(6.92) | 460.6<br>(18.13) | 327<br>(12.87) | 88.1<br>(3.46) | 232.3<br>(9.14) | 5<br>(0.19) | 5<br>(0.19) |

Installing  
the Inverter

## SV0110-0150iS7 (200 V/400 V)

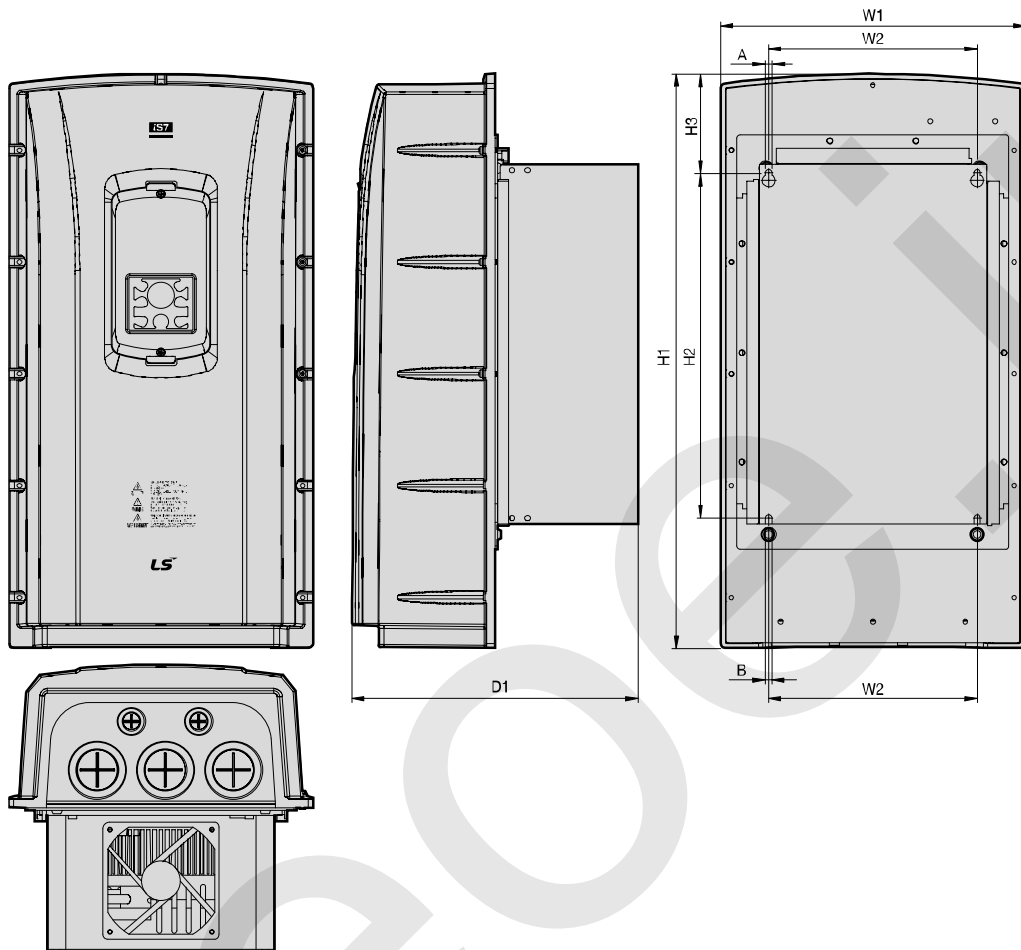

Units: mm (inch)

| Inverter Capacity   | W1               | W2              | H1               | H2             | H3             | D1               | A             | B             |
|---------------------|------------------|-----------------|------------------|----------------|----------------|------------------|---------------|---------------|
| SV0110-0150 iS7-2/4 | 313.1<br>(12.32) | 214.6<br>(8.44) | 590.8<br>(23.25) | 355<br>(13.97) | 101.7<br>(4.0) | 294.4<br>(11.59) | 6.5<br>(0.25) | 6.5<br>(0.25) |

SV0185-0220iS7 (200 V/400 V)

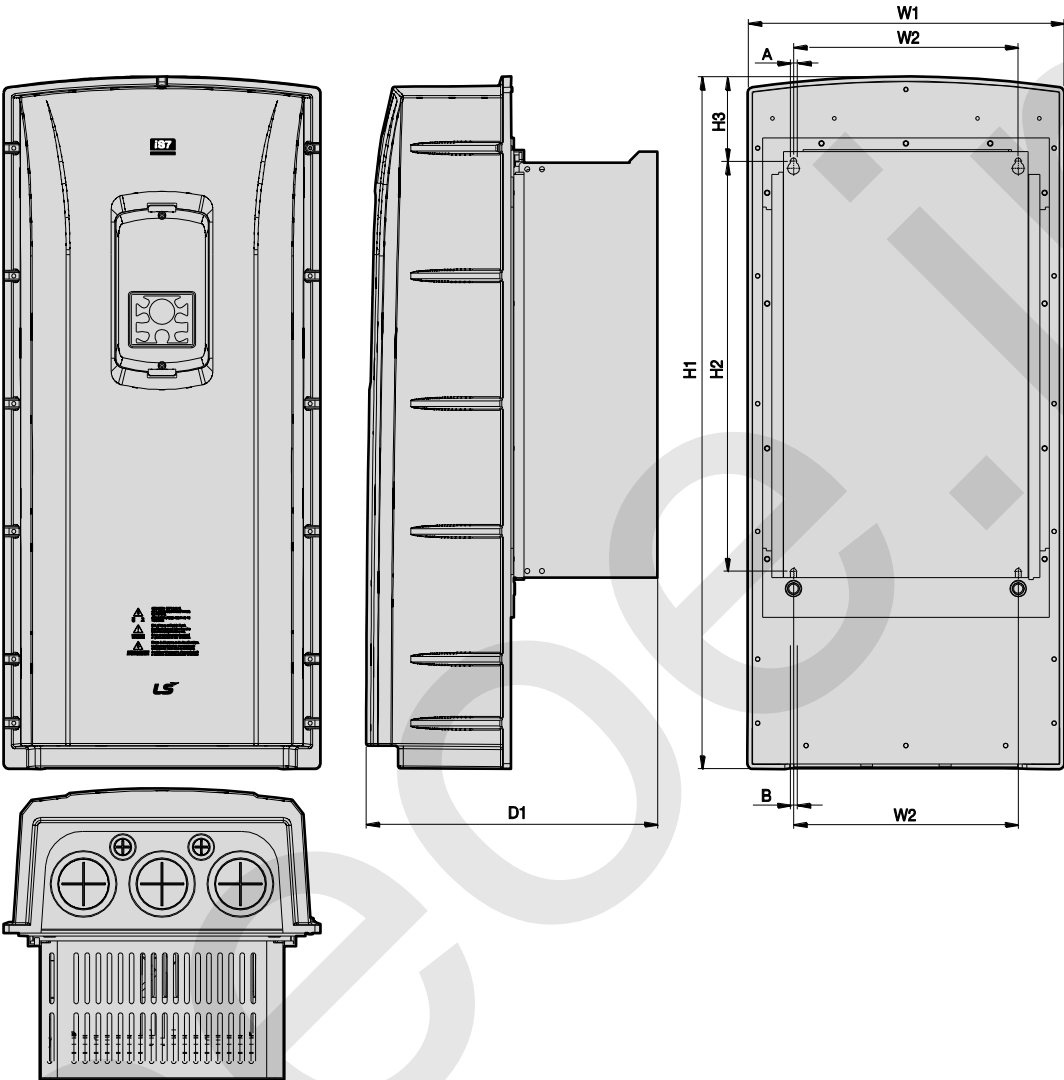

Units: mm (inch)

| Inverter Capacity   | W1               | W2              | H1               | H2             | H3             | D1               | A             | B             |
|---------------------|------------------|-----------------|------------------|----------------|----------------|------------------|---------------|---------------|
| SV0185-0220 iS7-2/4 | 343.2<br>(13.51) | 243.5<br>(9.58) | 750.8<br>(29.55) | 445<br>(17.51) | 91.6<br>(3.60) | 315.5<br>(12.42) | 6.5<br>(0.25) | 6.5<br>(0.25) |

Installing  
the Inverter



### 3.5 Frame Dimensions and Weight (UL Enclosed Type 1, IP 21 Type)

| Inverter Capacity | W[mm] | H[mm] | D[mm] | Weight[Kg] w/ built-in EMC and DCR | Weight[Kg] w/ built-in EMC | Weight[Kg] w/ built-in DCR | Weight[Kg] non-DCR types |
|-------------------|-------|-------|-------|------------------------------------|----------------------------|----------------------------|--------------------------|
| SV0008iS7-2/4     | 150   | 284   | 200   | 5.5                                | 4.5                        | 5.0                        | 4.5                      |
| SV0015iS7-2/4     | 150   | 284   | 200   | 5.5                                | 4.5                        | 5.0                        | 4.5                      |
| SV0022iS7-2/4     | 150   | 284   | 200   | 5.5                                | 4.5                        | 5.0                        | 4.5                      |
| SV0037iS7-2/4     | 150   | 284   | 200   | 5.5                                | 4.5                        | 5.0                        | 4.5                      |
| SV0055iS7-2/4     | 200   | 355   | 225   | 10                                 | 8.4                        | 9.3                        | 7.7                      |
| SV0075iS7-2/4     | 200   | 355   | 225   | 10                                 | 8.4                        | 9.3                        | 7.7                      |
| SV0110iS7-2/4     | 250   | 385   | 284   | 20                                 | 17.2                       | 16.8                       | 14                       |
| SV0150iS7-2/4     | 250   | 385   | 284   | 20                                 | 17.2                       | 16.8                       | 14                       |
| SV0185iS7-2       | 280   | 461.6 | 298   | 30                                 | 27                         | 25.9                       | 22.9                     |
| SV0220iS7-2       | 280   | 461.6 | 298   | 30                                 | 25.8                       | 25.9                       | 22.9                     |
| SV0185iS7-4       | 280   | 461.6 | 298   | 27.4                               | 23.5                       | 23.3                       | 19.7                     |
| SV0220iS7-4       | 280   | 461.6 | 298   | 27.4                               | 23.5                       | 23.5                       | 20.1                     |
| SV0300iS7-2       | 300   | 570   | 265.2 | -                                  | -                          | -                          | 29.5                     |
| SV0370iS7-2       | 370   | 630   | 281.2 | -                                  | -                          | -                          | 44                       |
| SV0450iS7-2       | 370   | 630   | 281.2 | -                                  | -                          | -                          | 44                       |
| SV0550iS7-2       | 465   | 750   | 355.6 | -                                  | -                          | -                          | 72.5                     |
| SV0750iS7-2       | 465   | 750   | 355.6 | -                                  | -                          | -                          | 72.5                     |

#### Note

- The weight specified in the table indicates the total weight of the product without packaging, which includes the built-in parts, such as the EMC filter and DCR.
- The built-in EMC filter and DCR are not available for 30–75 kW (200 V) products.

| Inverter Capacity | W[mm] | H[mm]  | D[mm] | Weight[Kg] w/ built-in EMC and DCR | Weight[Kg] w/ built-in EMC | Weight[Kg] w/ built-in DCR | Weight[Kg] non-DCR types |
|-------------------|-------|--------|-------|------------------------------------|----------------------------|----------------------------|--------------------------|
| SV0300iS7-4       | 300   | 594    | 300.4 | -                                  | -                          | 41                         | 28                       |
| SV0370iS7-4       | 300   | 594    | 300.4 | -                                  | -                          | 41                         | 28                       |
| SV0450iS7-4       | 300   | 594    | 300.4 | -                                  | -                          | 41                         | 28                       |
| SV0550iS7-4       | 370   | 663.4  | 371   | -                                  | -                          | 63                         | 45                       |
| SV0750iS7-4       | 370   | 663.4  | 371   | -                                  | -                          | 63                         | 45                       |
| SV0900iS7-4       | 510   | 784    | 423   | -                                  | -                          | 101                        | -                        |
| SV1100iS7-4       | 510   | 784    | 423   | -                                  | -                          | 101                        | -                        |
| SV1320iS7-4       | 510   | 861    | 423   | -                                  | -                          | 114                        | -                        |
| SV1600iS7-4       | 510   | 861    | 423   | -                                  | -                          | 114                        | -                        |
| SV1850iS7-4       | 690   | 1078   | 450   | -                                  | -                          | 200                        | -                        |
| SV2200iS7-4       | 690   | 1078   | 450   | -                                  | -                          | 200                        | -                        |
| SV2800iS7-4       | 771   | 1138   | 440   | -                                  | -                          | -                          | 252                      |
| SV3150iS7-4       | 922   | 1302.5 | 495   | -                                  | -                          | -                          | 352                      |
| SV3750iS7-4       | 922   | 1302.5 | 495   | -                                  | -                          | -                          | 352                      |

### Note

- The weight specified in the table indicates the total weight of the product without packaging, which includes built-in parts, such as the EMC filter and DCR.
- 300-220 kW (400 V) products have built-in DCR only.
- 280-375 kW (400 V) products are provided without a built-in EMC filter and DCR.

### 3.6 Frame Dimensions and Weight (UL Enclosed Type 12, IP54 Type)

| Inverter Capacity | W[mm] | H[mm] | D[mm] | Weight[Kg] w/ built-in EMC and DCR | Weight[Kg] w/ built-in EMC | Weight[Kg] w/ built-in DCR | Weight[Kg] non-DCR types |
|-------------------|-------|-------|-------|------------------------------------|----------------------------|----------------------------|--------------------------|
| SV0008iS7-2/4     | 204   | 419   | 208   | 8.2                                | 7.2                        | 7.7                        | 6.7                      |
| SV0015iS7-2/4     | 204   | 419   | 208   | 8.2                                | 7.2                        | 7.7                        | 6.7                      |
| SV0022iS7-2/4     | 204   | 419   | 208   | 8.2                                | 7.2                        | 7.7                        | 6.7                      |
| SV0037iS7-2/4     | 204   | 419   | 208   | 8.2                                | 7.2                        | 7.7                        | 6.7                      |
| SV0055iS7-2/4     | 254   | 461   | 232   | 12.8                               | 10.2                       | 12.1                       | 9.5                      |
| SV0075iS7-2/4     | 254   | 461   | 232   | 12.9                               | 10.3                       | 12.2                       | 9.6                      |
| SV0110iS7-2/4     | 313   | 591   | 294   | 25.6                               | 22.8                       | 22.4                       | 19.6                     |
| SV0150iS7-2/4     | 313   | 591   | 294   | 25.9                               | 23.1                       | 22.7                       | 19.9                     |
| SV0185iS7-2       | 343   | 751   | 316   | 38.3                               | 34.2                       | 34.1                       | 29.9                     |
| SV0220iS7-2       | 343   | 751   | 316   | 38.3                               | 34.2                       | 34.1                       | 29.9                     |
| SV0185iS7-4       | 343   | 751   | 316   | 34.9                               | 31                         | 31                         | 27.1                     |
| SV0220iS7-4       | 343   | 751   | 316   | 34.9                               | 31                         | 31                         | 27.1                     |

**Note**

- The weight specified in the table indicates the total weight of the product without packaging, which includes the built-in parts, such as the EMC filter and DCR.
- Only 0.75-22 kW products are available in IP 54 Type specifications.

## 3.7 Installation Procedures for UL Enclosed Type12 and IP54 Type Products

### 3.7.1 Disassembling the Keypad Cover and Keypad

- 1 Loosen the screws that secure the keypad cover and remove the keypad cover.

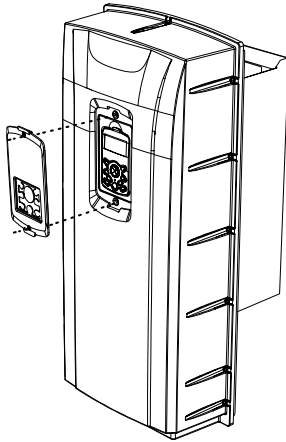

- 2 Depress the tab at the top of the keypad and gently lift the keypad from the inverter to remove it. Be careful not to damage the keypad cable.

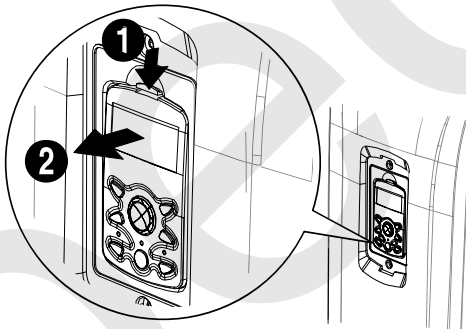

- 3 Depress the tab on the keypad cable connector and disconnect the cable from the back of the keypad.

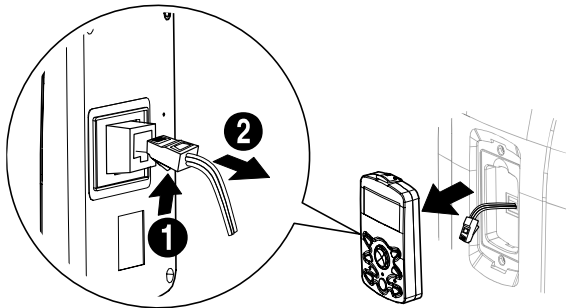

### 3.7.2 Disassembling the IP54 Front Cover

- 1 Loosen the screws that secure the front cover to the chassis. There are 9–13 screws on the cover depending on the model type.

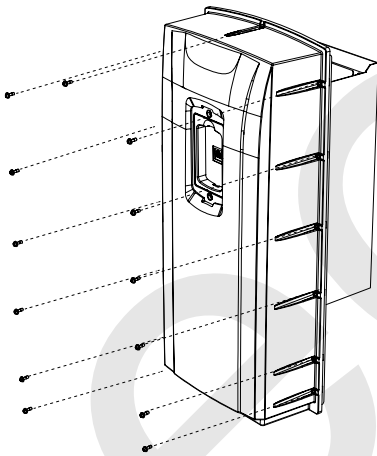

- 2 Remove the cover by lifting it upwards from the bottom.

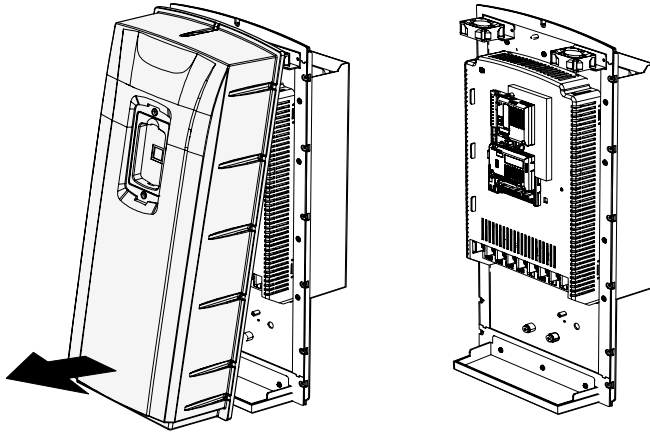

### 3.7.3 Mounting the Inverter

- 1 Remove the 4 rubber feet from the corners.

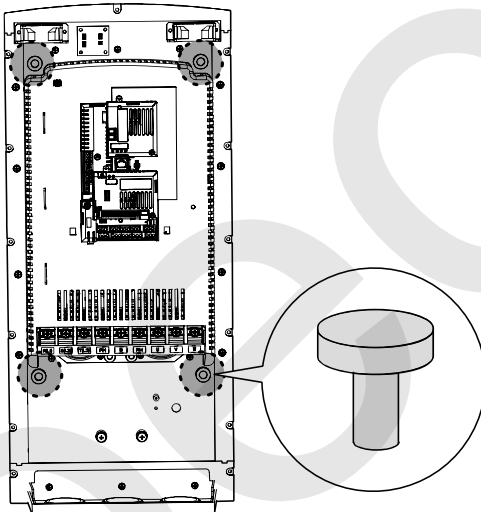

- 2 Place the inverter on a flat wall or in a cabinet, and use 4 screws or bolts to securely fix the inverter to the surface.

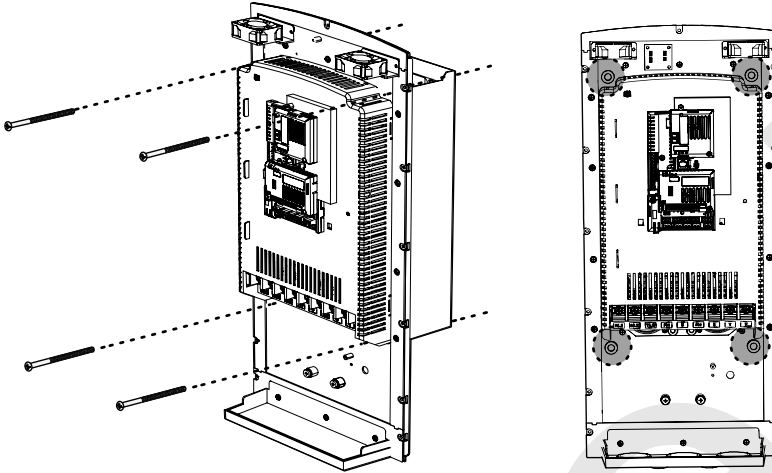

### 3.7.4 Connecting the Power Cables

Connect the power cables to the input (R, S, T) and output (U, V, W) terminals. Then, tighten the terminal screws.

Refer to [4 Connecting the Cables](#) on page [49](#) for detailed information.

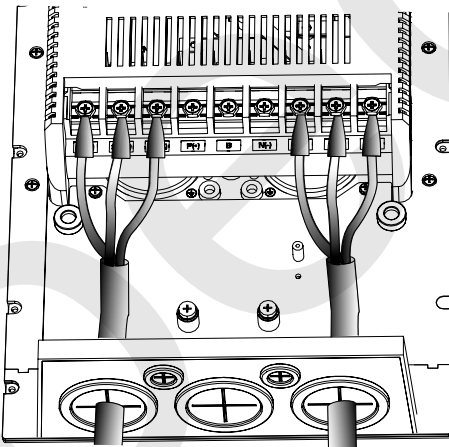

### 3.7.5 Reassembling the IP54 Front Cover and the Keypad

- 1 Place the front cover on the chassis and align the screw holes on each side.

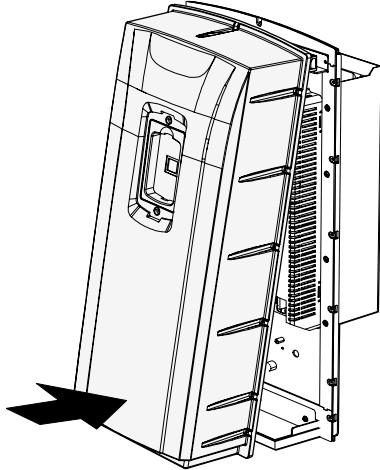

- 2 Insert and tighten the screws. There are 9–13 screws on the cover depending on the model type.

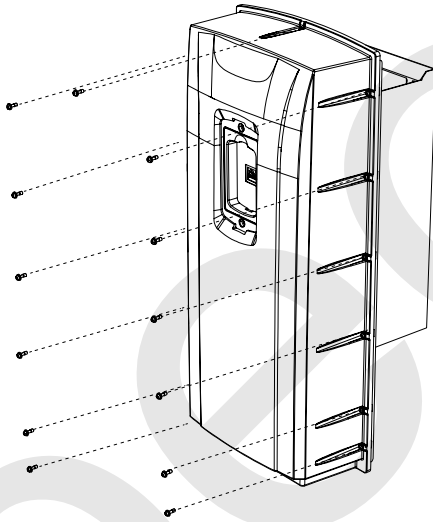



## Installing the Inverter

- 3 Connect the signal cable to the keypad, align the lower part of the keypad to the bottom of the keypad receptacle, and then push the top part of the keypad into the chassis until the keypad snaps into place.

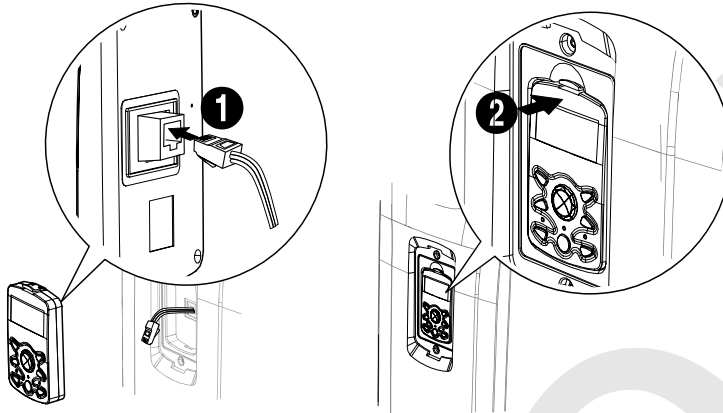

- 4 Place the keypad cover on top of the keypad, and secure it using 2 screws.

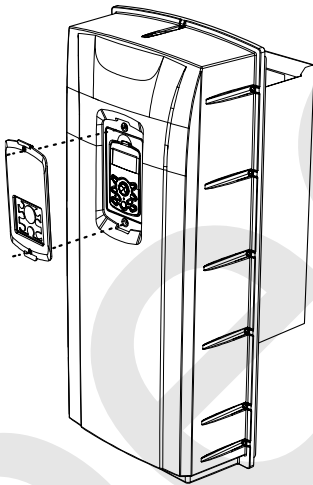

## 4 Connecting the Cables

Connect cables to the power and signal terminal blocks of the inverter.

### ⚠ Caution

ESD (Electrostatic discharge) from the human body may damage sensitive electronic components on the PCB. Therefore, be extremely careful not to touch the PCB or the components on the PCB with bare hands while you work on the I/O PCB.

To prevent damage to the PCB from ESD, touch a metal object with your hands to discharge any electricity before working on the PCB, or wear an anti-static wrist strap and ground it on a metal object.

### 4.1 Removing the Front Cover for Cable Connection

#### ⚠ Danger

Wait at least 10 minutes before opening the covers and exposing the terminal connections. Before working on the inverter, test the connections to ensure the DC voltage has been fully discharged. Personal injury or death by electric shock may result if the DC voltage has not been discharged.

#### 4.1.1 IP 21 Type Products

- 1 Depress the tab at the top of the keypad and gently lift the keypad from the inverter to remove it. Be careful not to damage the keypad cable.

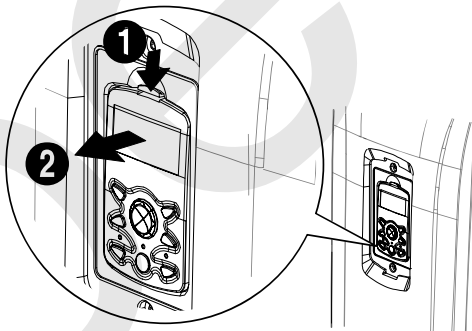

- 2 Depress the tab on the keypad cable connector and disconnect the cable from the back of the keypad.

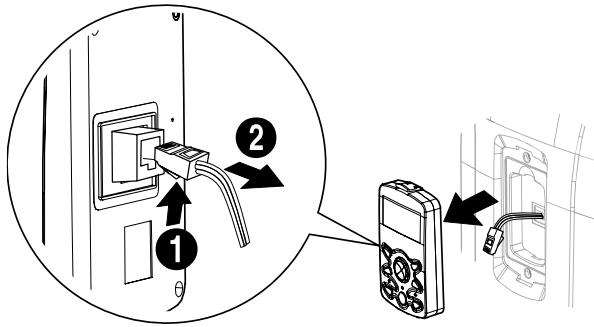

- 3 Loosen the screw from the bottom part of the front cover, and then remove the front cover.

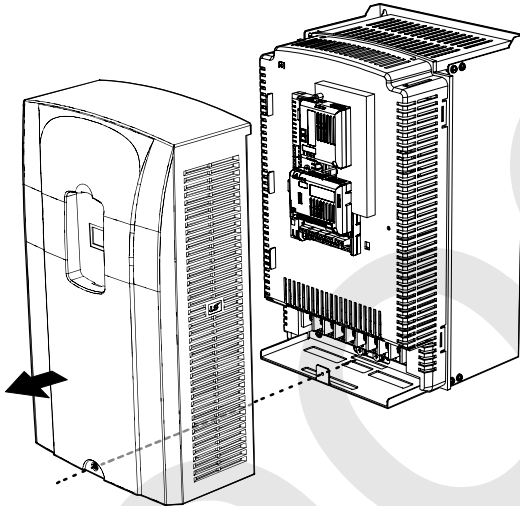

## 4.1.2 IP 54 Type Products

- 1 Loosen the two screws securing the keypad cover, and then remove the keypad cover.

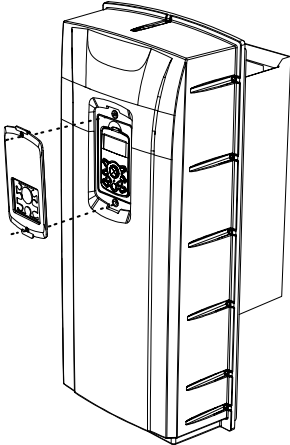

- 2 Depress the tab at the top of the keypad and gently lift the keypad from the inverter to remove it. Be careful not to damage the keypad cable.

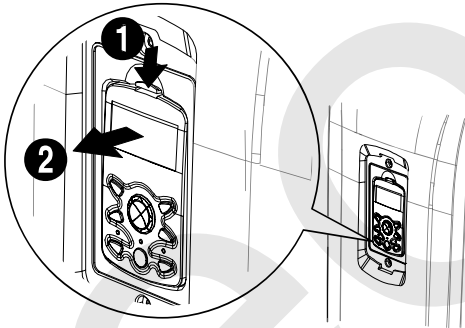

- 3 Depress the tab on the keypad cable connector and disconnect the cable from the back of the keypad.

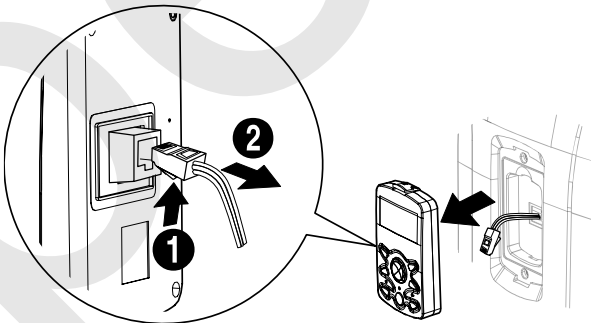

- 4 Remove the screws from each side of the front cover, and then remove the front cover.

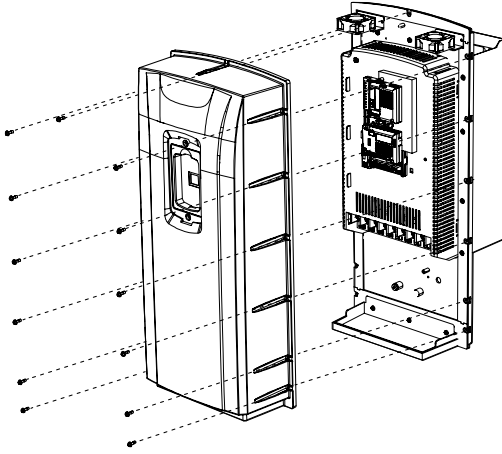

### 4.1.3 90–375 kW, 400 V and 30–75 kW, 200 V Products

- 1 Loosen the two screws on the front cover.

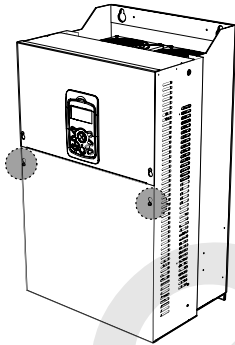

- 2 Slide the cover downwards and remove it from the inverter.

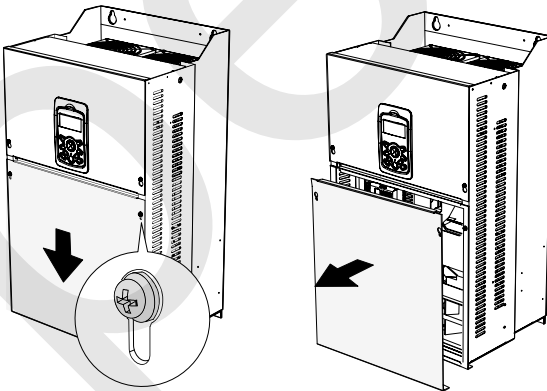

## 4.2 Activating and Deactivating the Built-in EMC Filter

Some iS-7 inverter models have built-in EMC filters to reduce conductive and radiational noise at the inverter input. Refer to *1.1.1 Identifying the Product* on page 1 and check your inverter's model type and specifications to see if it has a built-in EMC filter.

If your inverter has a built-in EMC filter, refer to the following instructions to activate or deactivate it.

### **⚠** Danger

Do not activate the EMC filter if the inverter uses a power source with an asymmetrical grounding structure, for example a grounded delta connection. Personal injury or death by electric shock may result if the power source is not grounded properly.

### 4.2.1 Up to 7.5 kW Inverters

- 1 Locate the plastic knockout cap that covers the EMC filter switch (jumper SW1).

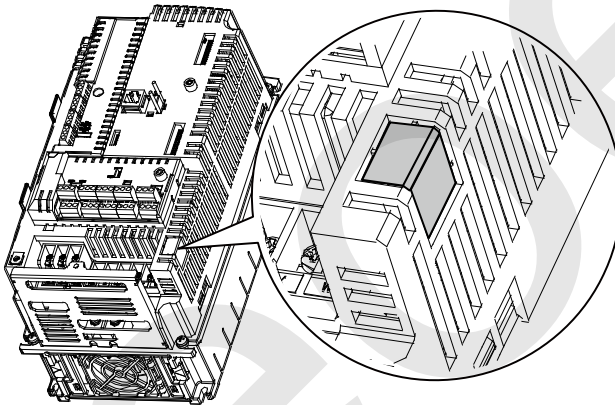

- 2 Remove the knockout cap and locate the jumper switch. The EMC filter will be deactivated if the two jumper pins are not connected.

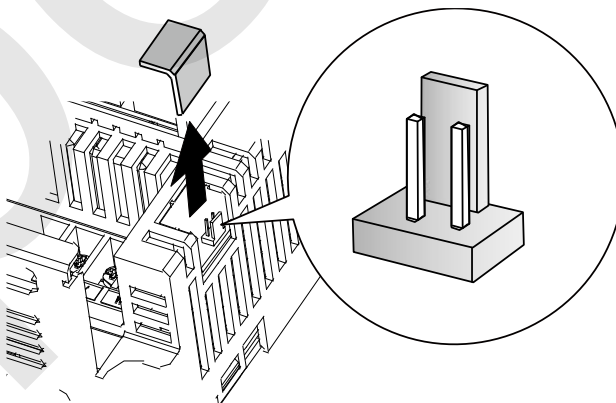

- 3 Connect the two jumper pins using a short circuit connector to activate the EMC filter.

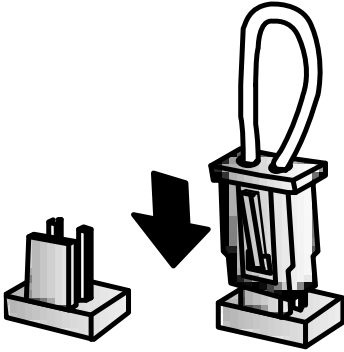

- 4 To remove the short circuit connector and deactivate the EMC filter, pull the connector while pressing the latch on the side of the connector. Use pliers or tweezers if you cannot reach the latch with your fingers.

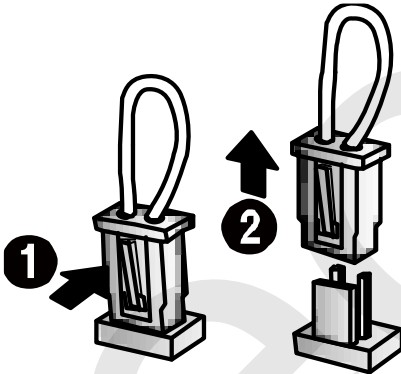

## 4.2.2 11–22 kW Inverters

- 1 Locate the EMC filter cable and the ground terminal at the bottom of the inverter.

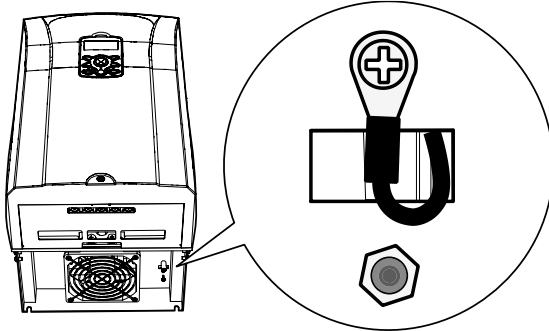

The EMC filter is deactivated if the EMC filter cable is connected to the insulated stud.



<EMC filter is turned OFF>

- 2 Remove the EMC filter cable from the insulated stud and connect it to the ground terminal (metal) to activate the EMC filter.

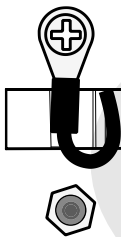

<EMC filter is turned ON>

An EMC filter prevents electromagnetic interference by reducing radio emissions from the inverter. Using an EMC filter is not always recommended, as it increases current leakage. If an inverter uses a power source with an asymmetrical grounding connection, the EMC filter must be turned off.

Before using the inverter, confirm the power supply's grounding system. Disable the EMC filter if the power source has an asymmetrical grounding connection.

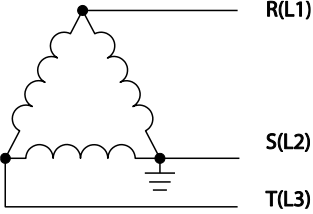
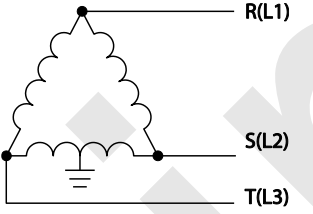
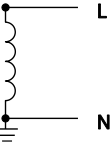
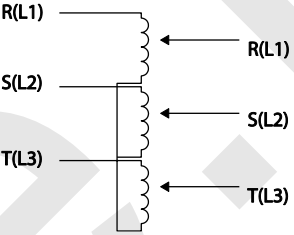

| Asymmetrical Grounding Connection                  |   |  |  |
|--|---|--|--|
| <p>One phase of a delta connection is grounded</p> |  | <p>Intermediate grounding point on one phase of a delta connection</p> |  |
| <p>The end of a single phase is grounded</p>       |  | <p>A 3-phase connection without grounding</p>                          |  |

## Note

- When the EMC Filter is deactivated, the Y-CAP is disconnected from Ground

## 4.3 Precautions for Wiring the Inverter

### ⚠ Warning

- Do not connect power to the inverter until installation has been fully completed and the inverter is ready to be operated. Doing so may result in electric shock.
- Wiring and inspection of wiring must be performed by an authorized engineer.

### ⚠ Caution

- Install the inverter before connecting the cables.
- Ensure that no metal debris, such as wire clippings, remain inside the inverter. Metal debris in the inverter can cause inverter failure.
- Power supply cables must be connected to the R, S, and T terminals. Connecting power cables to other terminals will damage the inverter.
- Use insulated ring lugs when connecting cables to R/S/T and U/V/W terminals.
- The inverter's power terminal connections can cause harmonics that may interfere with other communication devices located near the inverter. To reduce interference, the installation of noise filters or line filters may be required.
- To avoid circuit interruption or damaging connected equipment, do not install phase-advanced condensers, surge protection, or electronic noise filters on the output side of the inverter.
- To avoid circuit interruption or damaging connected equipment, do not install magnetic contactors on the output side of the inverter.
- Make sure that the total cable length does not exceed 495 ft (150 m). For inverters  $\leq 3.7$  kW capacity, ensure that the total cable length does not exceed 165 ft (50 m). Long cable runs can cause reduced motor torque in low frequency applications due to voltage drop. Long cable runs also increase a circuit's susceptibility to stray capacitance and may trigger over-current protection devices or result in the malfunction of equipment connected to the inverter.
- Route the signal cables away from the power cables. Otherwise, signal errors may occur due to electric interference.
- Tighten terminal screws to their specified torques. Loose terminal block screws may allow the cables to disconnect and cause a short circuit or inverter failure. Refer to [4.7 Specifications of the Power Terminal Block and Exterior Fuse](#) on page [6666](#) for torque specifications.
- Do not place heavy objects on top of electric cables. Heavy objects may damage the cable and result in electric shock.
- Use cables with the largest cross-sectional area, appropriate for power terminal wiring, to ensure that voltage drops do not exceed 2%.
- Use copper cables rated at 600 V, 75°C for power terminal wiring.
- Use copper cables rated at 300 V, 75°C for control terminal wiring.
- If you need to rewire the terminals due to wiring-related faults, ensure that the inverter keypad display is turned off and the charge lamp under the terminal cover is off before working on wiring connections. The inverter may hold a high-voltage electric charge long after the power supply has been turned off.

## 4.4 Ground Connection

### Warning

Install ground connections for the inverter and the motor by following the correct specifications to ensure safe and accurate operation. Using the inverter and the motor without the specified grounding connections may result in electric shock.

### Caution

- Do not use the ground terminal as the signal (control) ground.
- Do not share the ground connection with other machines that consume a large amount of power, such as a welding machine.
- Connect the ground cable to the nearest earth contact and keep the cable length as short as possible.

Because the inverter is a high-frequency switching device, leakage current may occur during operation. To avoid the danger of electrocution due to current leakage, the inverter must be properly grounded. Ground connection must be made to the specified ground terminal on the inverter. Do not connect ground cables to chassis screws.

### Note

- 200 V products require Class 3 grounding. Resistance to ground must be  $\leq 100 \Omega$ .
- 400 V products require Special Class 3 grounding. Resistance to ground must be  $\leq 10 \Omega$ .

The following table lists the minimum ground cable specifications that must be met to properly ground the inverters.

| Inverter Capacity | Grounding wire size ( mm <sup>2</sup> ) |             |
|-------------------|---|-------------|
|                   | 200 V class                             | 400 V class |
| 0.75–3.7kW        | 4                                       | 2.5         |
| 5.5–7.5 kW        | 6                                       | 4           |
| 11–15 kW          | 16                                      | 10          |
| 18.5–22 kW        | 25                                      | 16          |
| 30–45 kW          | 25                                      | 16          |
| 55–75 kW          | 35                                      | 35          |
| 90–110 kW         | -                                       | 60          |
| 132–220 kW        | -                                       | 100         |
| 280–315 kW        | -                                       | 185         |
| 375 kW            | -                                       | 240         |

## 4.5 Terminal Wiring Diagram

### 4.5.1 Up to 7.5 kW Inverters

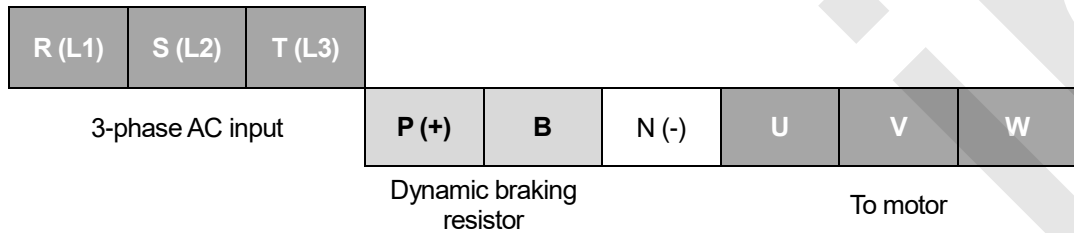

### 4.5.2 11–22 kW Inverters

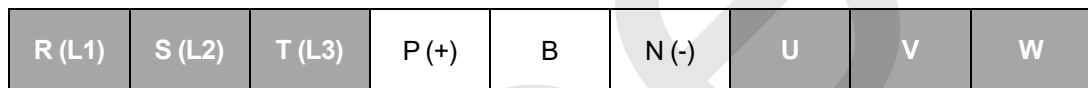

### 4.5.3 30–75 kW Inverters

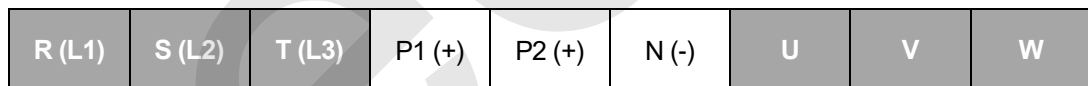

### 4.5.4 90–160 kW Inverters

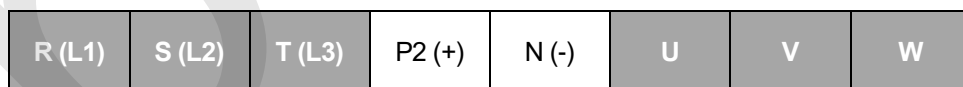

### 4.5.5 185–220 kW Inverters

|        |        |        |        |       |   |   |   |
|--------|--------|--------|--------|-------|---|---|---|
| R (L1) | S (L2) | T (L3) | P2 (+) | N (-) | U | V | W |
|--------|--------|--------|--------|-------|---|---|---|

### 4.5.6 280–375 kW Inverters

|        |        |        |        |        |       |   |   |   |
|--------|--------|--------|--------|--------|-------|---|---|---|
| R (L1) | S (L2) | T (L3) | P1 (+) | P2 (+) | N (-) | U | V | W |
|--------|--------|--------|--------|--------|-------|---|---|---|

#### Note

- Inverters with a rated capacity of 11 kW or more are equipped with linearly arranged terminal blocks.
- 0.75–22 kW inverters have built-in DC reactors. The installation of an external DC reactor is not necessary for these inverters.
- The inverter must be properly grounded using the ground terminal.

#### Note

If the forward command (Fx) is turned on, the motor should rotate counterclockwise when viewed from the load side of the motor. If the motor rotates in the reverse direction, switch the cables at the U and V terminals.

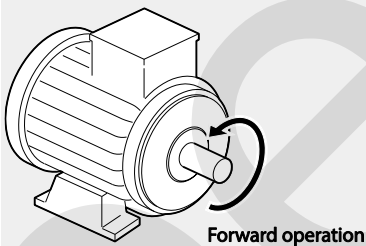

#### Remarque

Si la commande avant (Fx) est activée, le moteur doit tourner dans le sens anti-horaire si on le regarde côté charge du moteur. Si le moteur tourne dans le sens inverse, inverser les câbles aux bornes U et V.

## 4.6 Connecting Cables to the Power Terminal Block

### ⚠ Caution

Power supply cables must be connected to the R, S, and T terminals. Connecting power cables to other terminals will damage the inverter.

### Note

The motor will rotate in the opposite direction if the U, V, and W terminals are connected in a wrong phase order.

### 4.6.1 0.75–22 kW (200 V/400 V)

#### Cable connection for utilizing the built-in dynamic braking unit

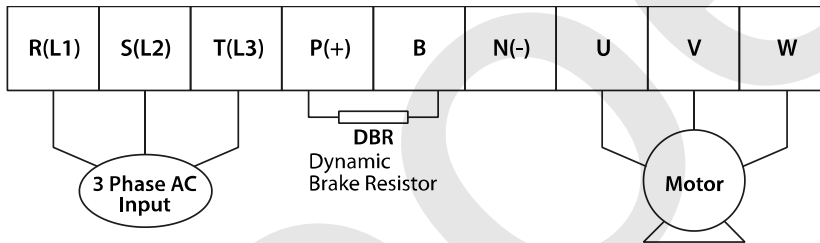

Connect the cables from the dynamic braking unit to the P (+) and B terminals to utilize the built-in dynamic braking unit.

| Terminal Symbol        | Terminal Name                      | Description                                   |
|------------------------|------------------------------------|---|
| R (L1), S (L2), T (L3) | AC power supply input terminals    | AC input terminals                            |
| P (+)                  | (+) DC voltage terminal            | (+) DC link voltage terminal                  |
| N (-)                  | (-) DC voltage terminal            | (-) DC link voltage terminal.                 |
| P (+), B               | Dynamic braking resistor terminals | Dynamic braking resistor terminals            |
| U, V, W                | Inverter output terminals          | Output terminals to a 3-phase induction motor |

## Cable connection for utilizing the optional dynamic braking unit

Connect the cables from dynamic braking unit to P (+) and N (-) terminals to utilize the optional dynamic braking unit. Do not connect cables to B terminal.

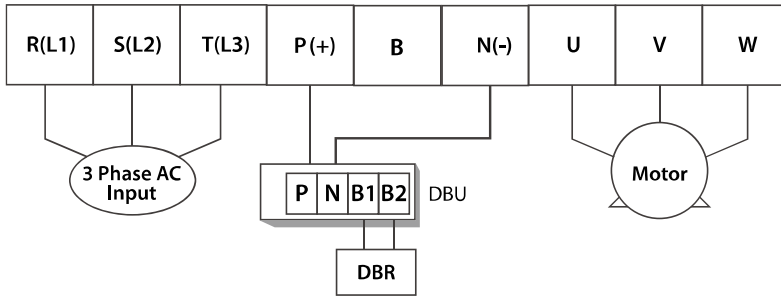

| Terminal Symbol        | Terminal Name                      | Description                                   |
|------------------------|------------------------------------|---|
| R (L1), S (L2), T (L3) | AC power supply input terminals    | AC input terminals                            |
| P (+)                  | (+) DC voltage terminal            | (+) DC link voltage terminal                  |
| N (-)                  | (-) DC voltage terminal            | (-) DC link voltage terminal.                 |
| P (+), B               | Dynamic braking resistor terminals | Dynamic braking resistor terminals            |
| U, V, W                | Inverter output terminals          | Output terminals to a 3-phase induction motor |

## 4.6.2 30–75 kW (200 V/400 V)

Connect the cables from the dynamic braking unit to the P (+) and B terminals to utilize the built-in dynamic braking unit.

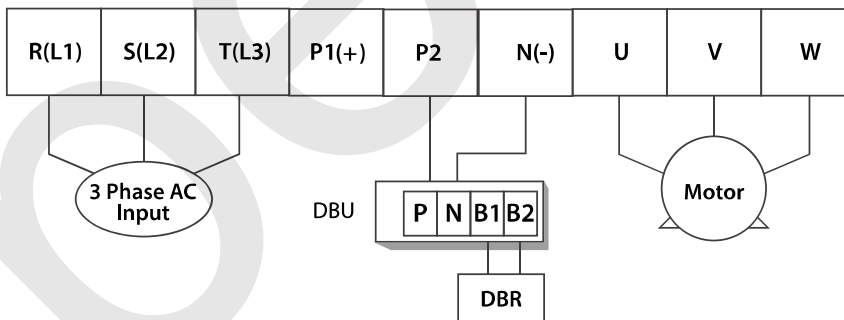

In 30-75 kW 200 V model types, the P1 and P2 terminals are connected with a jumper pin.

| Terminal Symbol        | Terminal Name                   | Description        |
|------------------------|---------------------------------|--------------------|
| R (L1), S (L2), T (L3) | AC power supply input terminals | AC input terminals |

| Terminal Symbol | Terminal Name                                  | Description                                   |
|-----------------|--|---|
| P1 (+)          | (+) DC voltage terminal                        | (+) DC link voltage terminal                  |
| P2, N (-)       | Dynamic braking resistor terminal / DC common* | Dynamic braking resistor terminals            |
| N (-)           | (-) DC voltage terminal                        | (-) DC link voltage terminal                  |
| U, V, W         | Inverter output terminals                      | Output terminals to a 3-phase induction motor |

\*Contact LS ELECTRIC Customer Support before configuring the P2 (+) and N (-) terminals as the DC common source. There are a few factors that require special attention for this application.

### Note

External DC reactors cannot be used with 30–75 kW inverters. To use a DC reactor with these inverters, purchase a 30–75 kW inverter that has a built-in DC reactor.

### ⚠ Caution

- When a built-in DCR unit is present, the P1 (+) and P (-) terminals are connected to the reactor's input and output terminals respectively.
- If your product does not have a built-in DCR unit, the P2 (+) and N (-) terminals may be used as the common DC source. Do not use the P1 (+) terminal as the common DC source, as this may result in product damage.
- Use the P2 (+) and N (-) terminals to connect a dynamic braking resistor to the inverter. Do not connect the dynamic braking unit to the P1 (+) terminal, as this may result in product damage.
- Contact LS ELECTRIC Customer Support before configuring the N (-) terminal as the DC common source. There are a few factors that require special attention for this application.

## 4.6.3 90–160 kW (400 V)

Connect the cables from the dynamic braking unit to the P2 (+) and N (-) terminals to utilize an external dynamic braking unit.

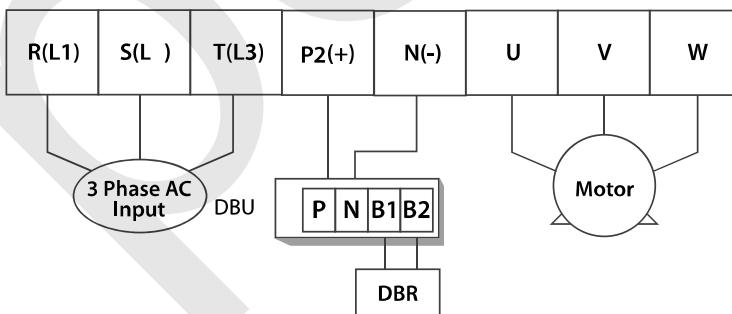

| Terminal Symbol | Terminal Name | Description |
|-----------------|---------------|-------------|
|-----------------|---------------|-------------|



| Terminal Symbol        | Terminal Name                     | Description                                   |
|------------------------|-----------------------------------|---|
| R (L1), S (L2), T (L3) | AC power supply input terminals   | AC input terminals                            |
| N (-)                  | (-) DC voltage terminal           | (-) DC link voltage terminal                  |
| P2 (+), N (-)          | Dynamic braking resistor terminal | Dynamic braking resistor terminals            |
| U, V, W                | Inverter output terminals         | Output terminals to a 3-phase induction motor |

### 4.6.4 185–220 kW (400 V)

Connect the cables from the dynamic braking unit to the P2 (+) and N (-) terminals to utilize an external dynamic braking unit.

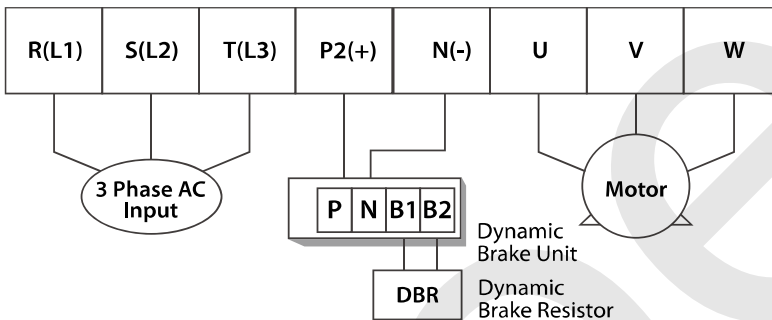

| Terminal Symbol        | Terminal Name                     | Description                                   |
|------------------------|-----------------------------------|---|
| R (L1), S (L2), T (L3) | AC power supply input terminals   | AC input terminals                            |
| N (-)                  | (-) DC voltage terminal           | (-) DC link voltage terminal                  |
| P2 (+), N (-)          | Dynamic braking resistor terminal | Dynamic braking resistor terminals            |
| U, V, W                | Inverter output terminals         | Output terminals to a 3-phase induction motor |

### 4.6.5 280–375 kW (200 V/400 V)

Connect the cables from the dynamic braking unit to the P2 (+) and N (-) terminals to utilize the built-in dynamic braking unit.

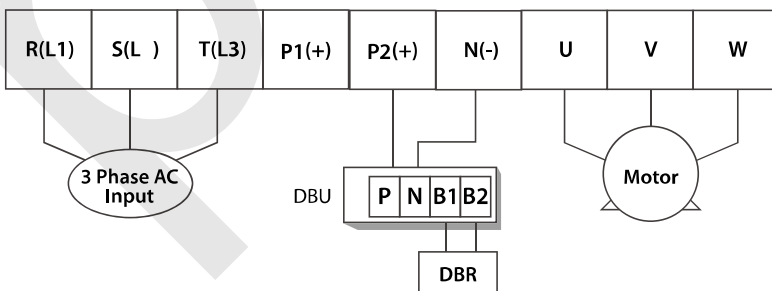

| Terminal Symbol        | Terminal Name                                  | Description                                   |
|------------------------|--|---|
| R (L1), S (L2), T (L3) | AC power supply input terminals                | AC input terminals                            |
| P1 (+)                 | (+) DC voltage terminal                        | (+) DC link voltage terminal                  |
| P2/N (-)               | Dynamic braking resistor terminal / DC common* | Dynamic braking resistor terminals            |
| N (-)                  | (-) DC voltage terminal                        | (-) DC link voltage terminal                  |
| U, V, W                | Inverter output terminals                      | Output terminals to a 3-phase induction motor |

\*Contact LS ELECTRIC Customer Support before configuring the P2 (+) and N (-) terminals as the DC common source. There are a few factors that require special attention for this application.

### ⚠ Caution

- Apply rated torques to the terminal screws. Loose screws may cause the terminals to short circuit and malfunction. Tightening the screws too much may damage the terminals and cause them to short circuit and malfunction.
- Only use copper wires with a 600 V, 75 °C rating for the power terminal wiring, and a 300 V, 75 °C rating for the control terminal wiring.
- Power supply wiring must be connected to the R, S, and T terminals. Connecting them to the U, V, W terminals causes internal damage to the inverter. The motor should be connected to the U, V, and W terminals. Arrangement of the phase sequence is not necessary.

## 4.7 Specifications of the Power Terminal Block and Exterior Fuse

| Inverter capacity | Terminal screw size | Screw torque <sup>1)</sup><br>(Kgf·cm) | Cable <sup>2)</sup> |       |              |       | Exterior fuse |         |       |
|-------------------|---------------------|--|---------------------|-------|--------------|-------|---------------|---------|-------|
|                   |                     |  | mm <sup>2</sup>     |       | AWG or kcmil |       | Current       | Voltage |       |
|                   |                     |  | R,S,T               | U,V,W | R,S,T        | U,V,W |               |         |       |
| 200V              | 0.75 kW             | M4                                     | 7.1–12              | 2.5   | 2.5          | 14    | 14            | 10 A    | 500 V |
|                   | 1.5 kW              | M4                                     | 7.1–12              | 2.5   | 2.5          | 14    | 14            | 15 A    | 500 V |
|                   | 2.2 kW              | M4                                     | 7.1–12              | 2.5   | 2.5          | 14    | 14            | 20 A    | 500 V |
|                   | 3.7 kW              | M4                                     | 7.1–12              | 4     | 4            | 12    | 12            | 32 A    | 500 V |
|                   | 5.5 kW              | M4                                     | 7.1–12              | 6     | 6            | 10    | 10            | 50 A    | 500 V |
|                   | 7.5 kW              | M4                                     | 7.1–12              | 10    | 10           | 8     | 8             | 63 A    | 500 V |
|                   | 11 kW               | M6                                     | 30.6–38.2           | 16    | 16           | 6     | 6             | 80 A    | 500 V |
|                   | 15 kW               | M6                                     | 30.6–38.2           | 25    | 25           | 4     | 4             | 100 A   | 500 V |
|                   | 18.5 kW             | M8                                     | 61.2–91.8           | 35    | 35           | 2     | 2             | 125 A   | 500 V |
|                   | 22 kW               | M8                                     | 61.2–91.8           | 50    | 50           | 1     | 1             | 160 A   | 500 V |
|                   | 30 kW               | M8                                     | 61.2–91.8           | 70    | 70           | 1/0   | 1/0           | 200 A   | 500 V |
|                   | 37 kW               | M8                                     | 61.2–91.8           | 95    | 95           | 2/0   | 2/0           | 250 A   | 500 V |
|                   | 45 kW               | M8                                     | 61.2–91.8           | 95    | 95           | 2/0   | 2/0           | 350 A   | 500 V |
|                   | 55 kW               | M10                                    | 89.7–122.0          | 120   | 120          | 3/0   | 3/0           | 400 A   | 500 V |
| 75 kW             | M10                 | 89.7–122.0                             | 150                 | 150   | 4/0          | 4/0   | 450 A         | 500 V   |       |
| 400V              | 0.75–1.5kW          | M4                                     | 7.1–12              | 2.5   | 2.5          | 14    | 14            | 10 A    | 500 V |
|                   | 2.2 kW              | M4                                     | 7.1–12              | 2.5   | 2.5          | 14    | 14            | 15 A    | 500 V |
|                   | 3.7 kW              | M4                                     | 7.1–12              | 2.5   | 2.5          | 14    | 14            | 20 A    | 500 V |
|                   | 5.5 kW              | M4                                     | 7.1–12              | 4     | 2.5          | 12    | 14            | 32 A    | 500 V |
|                   | 7.5 kW              | M4                                     | 7.1–12              | 4     | 4            | 12    | 12            | 35 A    | 500 V |
|                   | 11 kW               | M5                                     | 24.5–31.8           | 6     | 6            | 10    | 10            | 50 A    | 500 V |
|                   | 15 kW               | M5                                     | 24.5–31.8           | 10    | 10           | 8     | 8             | 63 A    | 500 V |
|                   | 18.5 kW             | M6                                     | 30.6–38.2           | 16    | 10           | 6     | 8             | 70 A    | 500 V |
|                   | 22 kW               | M6                                     | 30.6–38.2           | 25    | 16           | 4     | 6             | 100 A   | 500 V |
|                   | 30 kW               | M8                                     | 61.2–91.8           | 25    | 25           | 4     | 4             | 125 A   | 500 V |
|                   | 37 kW               | M8                                     | 61.2–91.8           | 25    | 35           | 4     | 2             | 125 A   | 500 V |
|                   | 45 kW               | M8                                     | 61.2–91.8           | 50    | 50           | 1     | 1             | 160 A   | 500 V |
|                   | 55 kW               | M8                                     | 61.2–91.8           | 70    | 70           | 1/0   | 1/0           | 200 A   | 500 V |
|                   | 75 kW               | M8                                     | 61.2–91.8           | 95    | 95           | 2/0   | 2/0           | 250 A   | 500 V |
|                   | 90 kW               | M12                                    | 182.4–215.0         | 100   | 100          | 4/0   | 4/0           | 350 A   | 500 V |
|                   | 110 kW              | M12                                    | 182.4–215.0         | 100   | 100          | 4/0   | 4/0           | 400 A   | 500 V |
|                   | 132 kW              | M12                                    | 182.4–215.0         | 150   | 150          | 300   | 300           | 450 A   | 500 V |
|                   | 160 kW              | M12                                    | 182.4–215.0         | 200   | 200          | 400   | 400           | 450 A   | 500 V |
| 185 kW            | M12                 | 182.4–215.0                            | 200                 | 200   | 400          | 400   | 620 A         | 500 V   |       |
| 220 kW            | M12                 | 182.4–215.0                            | 250                 | 250   | 500          | 500   | 800 A         | 500 V   |       |
| 280 kW            | M12                 | 182.4–215.0                            | 325                 | 325   | 650          | 650   | 1000 A        | 500 V   |       |
| 315 kW            | M12                 | 182.4–215.0                            | 2x200               | 2x200 | 2x400        | 2x400 | 1200 A        | 500 V   |       |
| 375 kW            | M12                 | 182.4–215.0                            | 2x250               | 2x250 | 2x500        | 2x500 | 1400 A        | 500 V   |       |

1) Apply rated torques to the terminal screws. Loose screws may cause the terminals to short circuit and malfunction.

2) Only use copper wires with a 600 V, 75°C rating for the power terminal wiring.

#### 4.7.1 Cable Length between the Inverter and the Motor

The maximum cable lengths of the inverter and the motor are listed in <Table 1) Maximum cable length by inverter capacity>.

Make sure that the total cable length does not exceed 495 ft (150 m). For inverters with a capacity of less than 3.7 kW, ensure that the total cable length does not exceed 165 ft (50 m). Long cable runs can cause reduced motor torque in low frequency applications due to voltage drop. Long cable runs also increase a circuit's susceptibility to stray capacitance and may trigger over-current protection devices, or result in the malfunction of equipment connected to the inverter.

<Table 1) Maximum Cable Length by Inverter Capacity>

| Inverter capacity    | Up to 3.7 kW    | 5.5 kW or more   |
|----------------------|-----------------|------------------|
| Maximum cable length | < 164 ft (50 m) | < 492 ft (150 m) |

The following table lists maximum carrier frequencies available for model types with a rated capacity of 5.5 kW or more.

<Table 2) Maximum Carrier Frequency according to Cable Length>

| Distance                  | < 165 ft (50 m) | < 330 ft (100 m) | > 330 ft (100 m) |
|---------------------------|-----------------|------------------|------------------|
| Allowed Carrier Frequency | <15 kHz         | <5 kHz           | <2.5 kHz         |

Depending on the system layout and operating conditions at the installation site, high peak output voltage may result.

a) If the output peak voltage is too high even when the motor cable length is shorter than the maximum recommended cable length for the inverter capacity:

- use a motor with a high insulation rating.
- install an output circuit filter (micro surge filter).
- install a dv/dt filter, or a sine wave filter.

b) If the cable length is too long:

- use thicker cables to prevent voltage drop.  
[Voltage Drop (V) =  $[\sqrt{3} \times \text{cable resistance (m}\Omega/\text{m)} \times \text{cable length (m)} \times \text{current (A)}] / 1000$ ]
- do not use 3-core cables.
- use a lower carrier frequency.

### 4.7.2 Protective Measures for the Inverter and the Motor

The inverter output voltage pulse, regardless of the actual output frequency, is identical to the DC link voltage pulse, which has a very short rising time. When the power is transmitted through the output cables, the output peak voltage can rise up to twice the total DC link voltage (2.8 times the main power voltage).

If a switching device (a magnetic contactor or relay) is connected to the output side of the inverter, high-voltage surges may result whenever a switch is made, regardless of the length of the motor cable.

Such high-voltage surges can damage the inverter's output components (such as the current sensor), motor cables, and the motor itself. To protect the inverter and the motor from such damage caused by a high-voltage surge, do not install switching devices in the output side of the inverter. You can install an output reactor, dv/dt filter, or sine wave filter to protect the inverter and motor from a surge voltage.

An output surge with a high switching frequency and fast rising time causes a motor shaft current that runs through the motor bearing. It slowly corrodes the surface of the motor bearing, eventually seizing up the motor.

To decrease the motor shaft current and protect the motor insulation, refer to <Table 1) Maximum cable length by inverter capacity>. Install a dv/dt filter or sine wave filter if possible, regardless of the length of the motor cable.

### ⚠ Caution

Only use Class H or RK5 UL listed input fuses and UL listed breakers. See the table above for the voltage and current ratings for the fuses and breakers.

Utiliser UNIQUEMENT des fusibles d'entrée homologués de Classe H ou RK5 UL et des disjoncteurs UL. Se reporter au tableau ci-dessus pour la tension et le courant nominal des fusibles et des disjoncteurs.

## 4.8 Control Terminal Wiring for iS7 Inverters Rated for Up To 22 kW

The iS7 inverter supports both PNP (Source) and NPN (Sink) modes for sequence inputs at the terminal. Select an appropriate mode to suit your requirements using the PNP/NPN selection switch above the control terminal block. Refer to the following information for detailed applications.

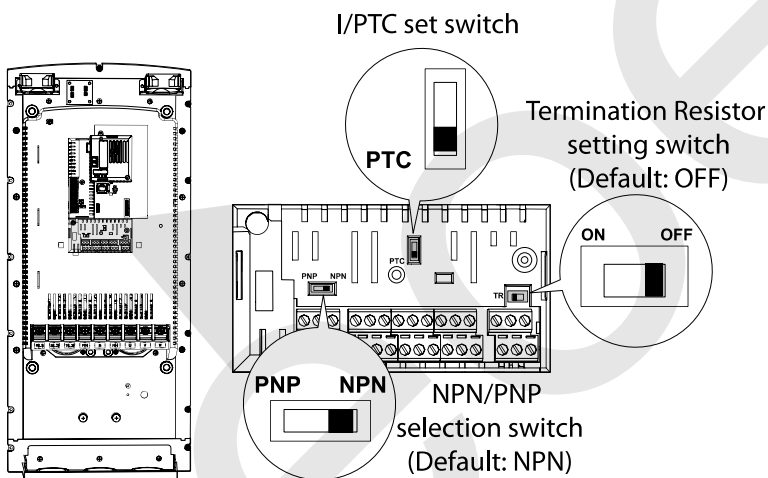

### 4.8.1 NPN Mode (Sink)

Select NPN using the PNP/NPN selection switch. The factory default setting is NPN mode. CM (24V GND) is the common ground terminal for all terminal inputs.

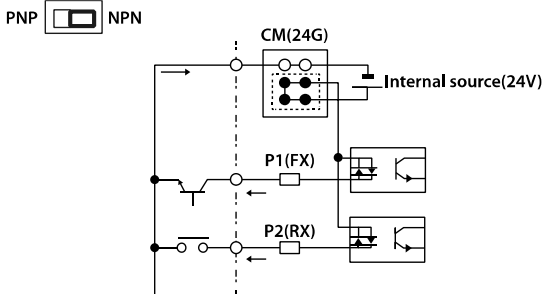

### 4.8.2 PNP Mode (Source)

Select PNP using the PNP/NPN selection switch. The factory default setting is NPN mode. CM (24 V GND) is the common ground terminal for all terminal inputs, and 24 is the 24 V internal source. If you are using an external 24 V source, select PNP (sink) mode and build a circuit that connects the external source (-) and the CM terminal.

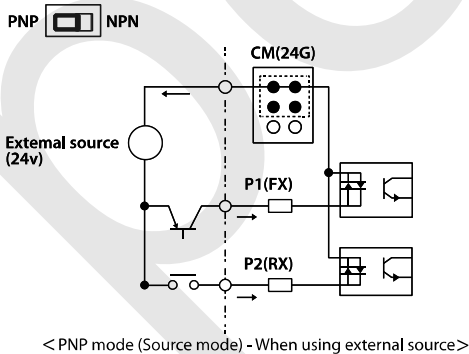
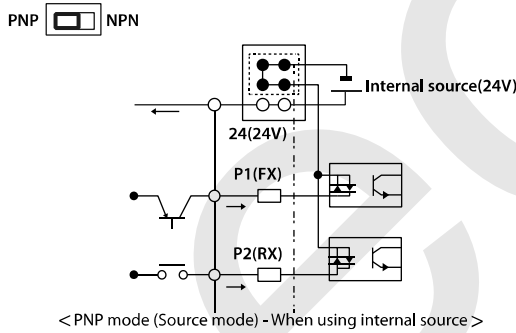

### 4.8.3 0.75–22 kW (Basic I/O)

#### Wiring Examples

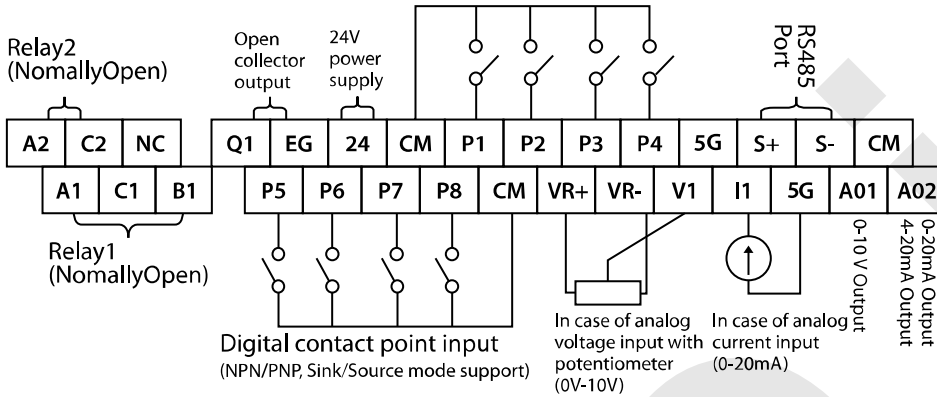

#### Default Functions Assigned for the Multi-Function Terminals

| P1 | P2 | P3 | P4  | P5   | P6   | P7   | P8  |
|----|----|----|-----|------|------|------|-----|
| FX | RX | BX | RST | Sp-L | Sp-M | Sp-H | JOG |

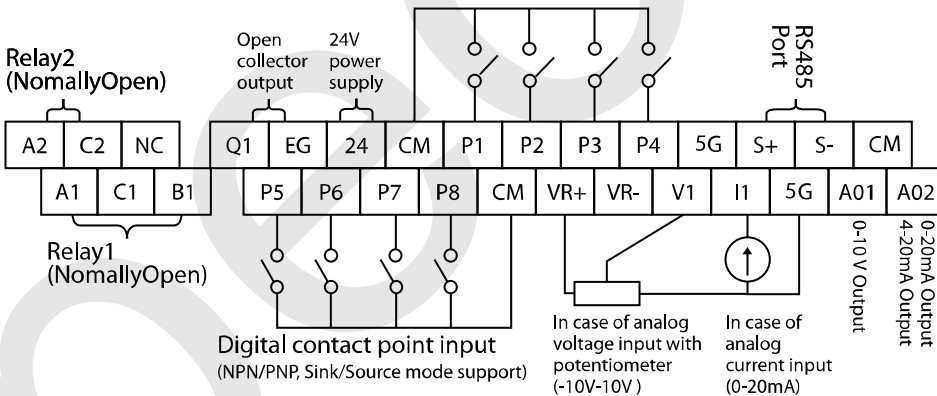

#### Note

- The TR (termination resistor) switch is used to terminate the RS485 network connection (120 Ω). Please turn on the TR switch of the last positioned Drive and turn off the TR switch of the remaining drives.
- For analog voltage input, use a potentiometer rated at 0.5W, 1kΩ.
- Refer to *13 Table of Functions* on page 381 for the multi-function terminal configurations.



## 4.9 Control Terminal Wiring for iS7 Inverters Rated for 30 kW or More

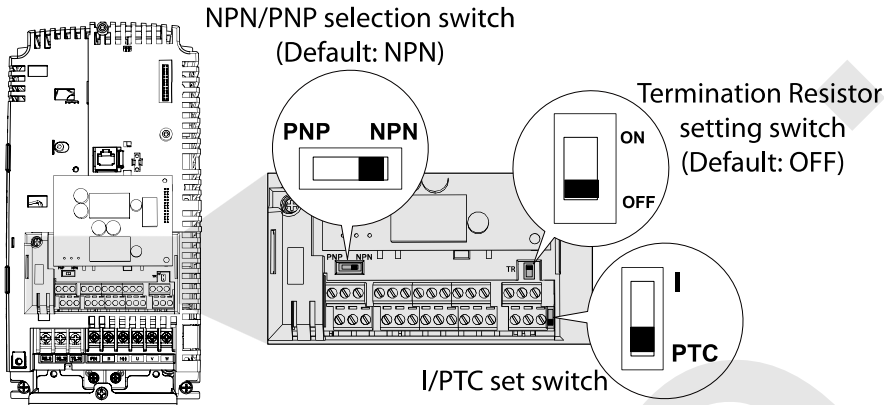

### 30–375 kW (control terminal block)

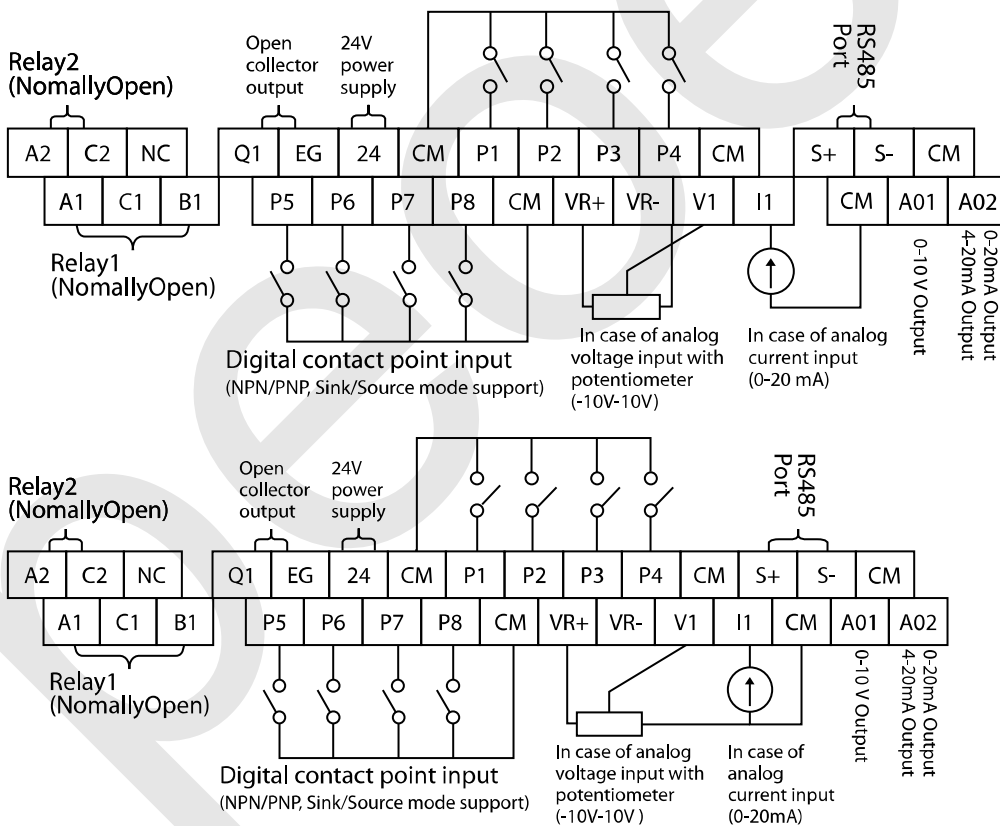

**Note**

- The TR (termination resistor) switch is used to terminate the RS485 network connection (120  $\Omega$ ). Please turn on the TR switch of the last positioned Drive and turn off the TR switch of the remaining drives.
- Use a potentiometer rated for 0.5 W, 1 k $\Omega$ .

If the analog voltage (V) or current (I) input is used to set the frequency reference, the analog input is reflected when the input is actually received. For instance, the voltage input 0 V at V1 does not indicate that no input is received at V1, but it means that 0 V input is actually received at V1.

**Note**

When you use the analog voltage input, the bipolar input range (-10 – +10V), in comparison to the unipolar input range (0–10V), allows for more accurate input control with smaller increments.

**⚠ Caution**

If the analog input is interrupted when setting a frequency reference using the analog voltage (V) input and no voltage input is received at the terminal, an offset voltage may be applied to keep the frequency reference at approximately 4–5 Hz.

## 4.10 Terminal Inputs for Inverter Operation

| Input Type     | Symbol | Name                                  | Description   |
|----------------|--------|---------------------------------------|---|
| Terminal input | P1–P8  | Multi-function input1–8               | Configurable for multi-function input terminals. Refer to <a href="#">13 Table of Functions</a> on page <a href="#">381</a> for the multi-function terminal configurations. |
|                | CM     | Common sequence                       | Common terminal for terminal inputs (5G common terminal is used for analog frequency inputs only).  |
| Input signal   | VR(+)  | Potentiometer frequency reference (+) | Used to setup or modify a frequency reference via the analog voltage or current input. Maximum output is +12 V, 100 mA.   |
|                | VR(-)  | Potentiometer frequency reference (-) | Used to setup or modify a frequency reference via the analog voltage or current input. Maximum output is -12 V, 100 mA.   |
|                | V1     | Voltage input for frequency reference | Used to setup or modify a frequency reference via the analog voltage input terminal.<br>Unipolar: 0–10 V<br>Bipolar: -10–10 V<br>Input resistance 20 k $\Omega$             |
|                | I1     | Current input for frequency reference | Used to setup or modify a frequency reference via the current input terminals.<br>Input current: DC 0–20 mA<br>Input resistance 249 $\Omega$                                |

## Connecting the Cables

| Input Type    | Symbol          | Name  | Description  |   |
|---------------|-----------------|---|--|---|
|               | 5G              | Frequency setting common terminal             | Common terminal for analog voltage and current terminals (CM common terminal is used for terminal inputs only).  |   |
| Analog output | AO1             | Multi-function analog voltage output terminal | Used to send inverter output information to external devices.<br>Output voltage: 0–10 V<br>Maximum output voltage: 10 V<br>Maximum output current: 10 mA |   |
|               | AO2             | Multi-function analog current output terminal | Used to send inverter output information to external devices.<br>Output current: 4–20 mA (0–20 mA)<br>Maximum output current: 20 mA                      |   |
| Output Signal | Terminal output | Q1  | Multi-function terminal (open collector)   | DC 26 V, below 100 mA   |
|               |                 | EG  | Common terminal for open collector   | Common ground contact for an open collector (with external power source).   |
|               |                 | 24  | External 24 V power source   | Maximum output current: 150 mA  |
|               |                 | CM  | External 24 V common   | Common ground contact for the external 24 V power source.   |
|               |                 | A1, B1, C1                                    | Fault signal output  | Sends out alarm signals when the inverter's safety features are activated (below AC 250 V 5 A, DC 30 V 5 A).<br>Fault condition: A1 and C1 contacts are connected (B1 and C1 open connection)<br>Normal operation: B1 and C1 contacts are connected (A1 and C1 open connection) |
|               |                 | A2, C2  | Multi-function relay2 output A contact   | Outputs the signal while running. User defined multi-function output terminal.<br>( < AC 250 V, 5 A / < DC 30 V, 5 A)   |
|               |                 | S+, S-, CM                                    | RS-485 signal line   | Used to send or receive RS-485 signals. Refer to <a href="#">11 Communication Function</a> on page 334.   |

## 4.11 Cable Specifications for Control Block Wiring

| Terminal Name |  | Cable size <sup>1)</sup>              |       | Specifications  |
|---------------|--|---------------------------------------|-------|---|
|               |  | mm <sup>2</sup>                       | AWG   |   |
| P1–P8         | Multi-function input terminal  | 0.33–<br>1.25                         | 16–22 | -   |
| CM            | Common terminal input (5G common is used for analog frequency inputs only).              |                                       |       | Common earth for multi-function input terminal  |
| VR+           | Analog frequency setting (+) power   |                                       |       | Output voltage: +12 V<br>Maximum output voltage: 100 mA                                     |
| VR-           | Analog frequency setting (-) power   |                                       |       | Output voltage: -12 V<br>Maximum output voltage: 100 mA                                     |
| V1            | Multi-function analog voltage input terminal   |                                       |       | Input voltage: 0–10 V or -10–10 V   |
| I1            | Multi-function analog current input terminal   |                                       |       | 0–20 mA input<br>Internal resistance: 249 Ω   |
| AO1           | Multi-function analog voltage output terminal  | 0.33–<br>2.0                          | 14–22 | Maximum output voltage: 10 V<br>Maximum output current: 10 mA                               |
| AO2           | Multi-function analog current output terminal  |                                       |       | Maximum output current: 20 mA   |
| 5G            | Frequency setting common terminal (CM common terminal is used for terminal inputs only). |                                       |       | Common terminal of analog frequency setting signal and analog current and voltage terminals |
| Q1            | Multi-function terminal (open collector)   |                                       |       | DC 26 V, below 100 mA   |
| EG            | Ground terminal for external power   |                                       |       | Common terminal for an open collector external power source                                 |
| 24            | External 24 V power supply   |                                       |       | Maximum output current: 150 mA  |
| CM            | 24 V common  | 0.33–<br>1.25                         | 16–22 | Common terminal for external 24 V power source  |
| A1            | Multi-function relay 1 output A  |                                       |       | 0.33–<br>2.0  |
| B1            | Multi-function relay 1 output B  | Below AC 250 V/5 A, Below DC 30 V/5 A |       |   |
| C1            | Multi-function relay 1 common terminal   | Below AC 250 V/5 A, Below DC 30 V/5 A |       |   |
| A2            | Multi-function relay 2 output A  | Below AC 250 V/5 A, Below DC 30 V/5 A |       |   |
| C2            | Multi-function relay 2 common terminal   | Below AC 250 V/5 A, Below DC 30 V/5 A |       |   |
| S+,S-         | RS485 signal input terminal  | 0.75                                  | 18    |   |
| CM            | RS485 common terminal  |                                       |       | For multi-connections, RS485 power ground (shield) connection terminal                      |

1) Use shielded, twisted-pair cables.

## 4.12 Control Terminal Wiring for iS7 Extension I/O (Optional)

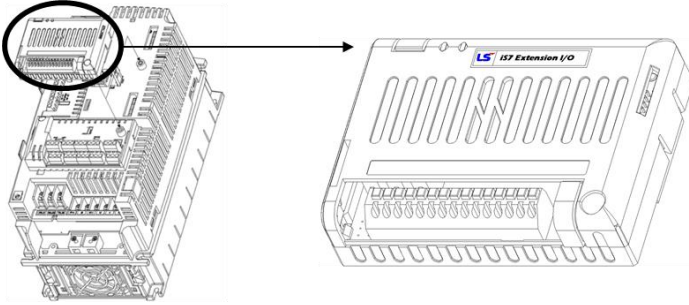

### Extension I/O (control terminal block)

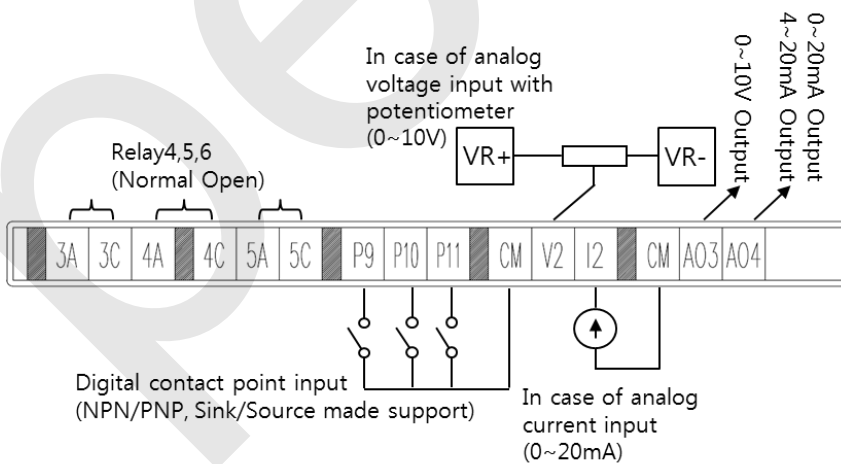
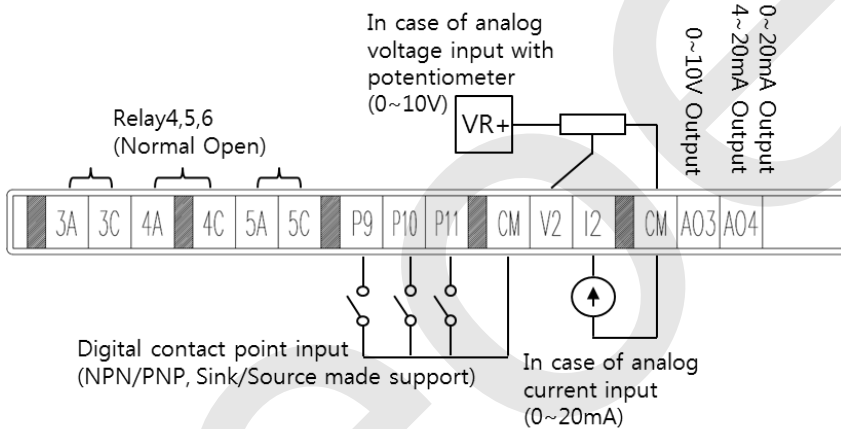

## 4.13 Terminal Inputs for Inverter Operation

| Input Type    | Symbol          | Name   | Description   |  |
|---------------|-----------------|--|---|--|
| Input signal  | Terminal input  | P9–P11   | Multi-function input9–11<br>Configurable for multi-function input terminals. Refer to <i>13 Table of Functions</i> on page 381 for the multi-function terminal configurations.                              |  |
|               |                 | CM   | Common sequence<br>Common terminal for terminal inputs  |  |
|               | Analog input    | V2   | Voltage input for frequency reference<br>Used to setup or modify a frequency reference via the analog voltage input terminal.<br>Unipolar: 0–10 V<br>Bipolar: -10–10 V<br>Input resistance 20 kΩ            |  |
|               |                 | I2   | Current input for frequency reference<br>Used to setup or modify a frequency reference via the current input terminals.<br>Input current: DC 0–20 mA<br>Input resistance 249 Ω                              |  |
| Output Signal | Analog output   | AO3  | Multi-function analog voltage output terminal<br>Used to send inverter output information to external devices.<br>Output voltage: -10–10 V<br>Maximum output voltage: 10 V<br>Maximum output current: 10 mA |  |
|               |                 | AO4  | Multi-function analog current output terminal<br>Used to send inverter output information to external devices.<br>Output current: 4–20 mA (0–20 mA)<br>Maximum output current: 20 mA                        |  |
|               | Terminal output | 3A, 3C   | Multi-function relay3 output A contact  | Outputs the signal while running. User defined multi-function output terminal.<br>(< AC 250 V, 5 A / < DC 30 V, 5 A) |
|               |                 | 4A, 4C   | Multi-function relay4 output A contact  |  |
| 5A, 5C        |                 | Multi-function relay5 output A contact   |   |  |
| CM            |                 | External 24 V common<br>Common ground contact for the external 24V power source. |   |  |

## 4.14 Cable Specifications for Control Block Wiring

| Terminal Name |   | Cable size <sup>1)</sup> |       | Specifications  |
|---------------|---|--------------------------|-------|---|
|               |   | mm <sup>2</sup>          | AWG   |   |
| P9–<br>P11    | Multi-function input terminal   | 0.33–<br>1.25            | 16–22 | -   |
| CM            | Common terminal input<br>(5G common is used for analog<br>frequency inputs only). |                          |       | Common earth for multi-function input<br>terminal             |
| V2            | Multi-function analog voltage<br>input terminal                                   |                          |       | Input voltage: 0–10 V or -10–10 V                             |
| I2            | Multi-function analog current<br>input terminal                                   |                          |       | 0–20 mA input<br>Internal resistance: 249 Ω                   |
| AO3           | Multi-function analog voltage<br>output terminal                                  |                          |       | Maximum output voltage: 10 V<br>Maximum output current: 10 mA |
| AO4           | Multi-function analog current<br>output terminal                                  |                          |       | Maximum output current: 20 mA                                 |
| CM            | 24 V common   |                          |       | Common terminal for external 24 V power<br>source             |
| 3A            | Multi-function relay 3 output A   |                          |       | Below AC 250 V/5 A, Below DC 30 V/5 A                         |
| 3C            | Multi-function relay 3<br>common terminal   |                          |       | Below AC 250 V/5 A, Below DC 30 V/5 A                         |
| 4A            | Multi-function relay 4 output A   |                          |       | Below AC 250 V/5 A, Below DC 30 V/5 A                         |
| 4C            | Multi-function relay 4<br>common terminal   |                          |       | Below AC 250 V/5 A, Below DC 30 V/5 A                         |
| 5A            | Multi-function relay 5 output A   |                          |       | Below AC 250 V/5 A, Below DC 30 V/5 A                         |
| 5C            | Multi-function relay 5<br>common terminal   |                          |       | Below AC 250 V/5 A, Below DC 30 V/5 A                         |

2) Use shielded, twisted-pair cables.

## 4.15 Setting the Built-in Surge Filter

The iS7 series inverters have a built-in surge filter between the input phases and the ground connection to absorb and mitigate surge current. This filter consists of a Y-CAP and multiple varistors.

However, in a non-grounded power system where specific ground faults occur frequently, adequate measures are required to avoid inverter damage.

Refer to the following table for details on how to prevent damage to specific power systems.

| Power supply system and ground type     | Varistors and Y-CAP connection | Effect   |
|---|--------------------------------|--|
| Directly grounded system                | 2-pin connector (on)           | Reduced voltage stress and noise                       |
| Non-grounded or impedance ground system | 2-pin connector (off)          | Reduced risk of inverter damage if ground fault occurs |

### Note

Not EMC Filter built-in type 0.75–22 kW (200/400 V) products do not support this function.

### ⚠ Caution

- You can deactivate the built-in surge filter if there is no risk of surge voltage occurring in the system.
- In order to prevent accidents, remove the jumper switch after the internal voltage of the inverter is completely discharged.



## 4.16 Activating or Deactivating the Surge Filter

### 4.16.1 iS7 30–75KW (400 V) Inverters

Contact LS ELECTRIC Customer Support and ask for assistance to deactivate the built-in surge filter for the 30–75 KW (400 V) inverters.

### 4.16.2 iS7 90–375 kW (400V) Inverters

Remove the keypad and the screws from the front cover, and then remove the front cover.

#### ⚠ Caution

Be careful not to open the front cover with the keypad attached, as this can damage the keypad cable.

Refer to the figure below and locate the SCR snubber board. On the circuit board, activate or deactivate the surge filter by connecting the two jumper pins or breaking the connection between the two pins using a jumper plug. The filter is turned on when the jumper plug is installed, and it is turned off when the jumper plug is removed.

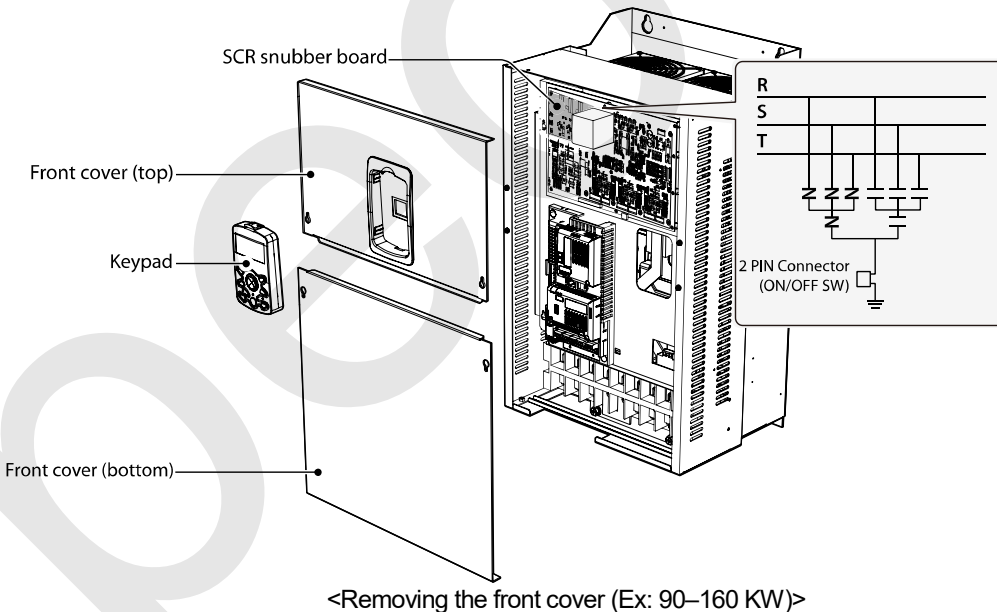

Refer to the following figures to locate the jumper switch on the SCR snubber board and install or remove the jumper cap to activate or deactivate the built-in surge filter.

SV900-1600iS7 (400 V)

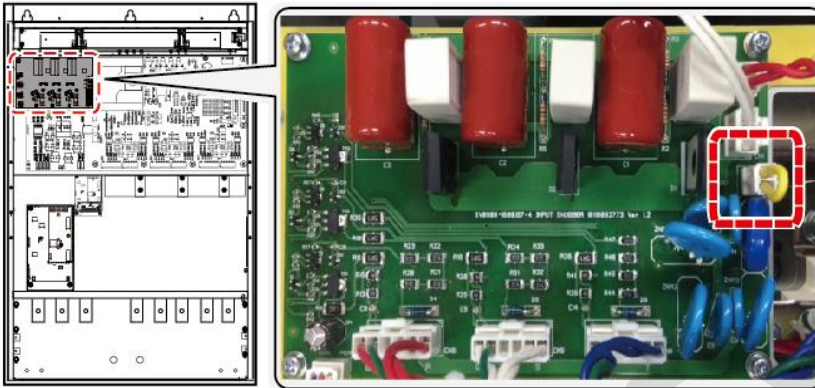

SV1850-2200iS7 (400 V)

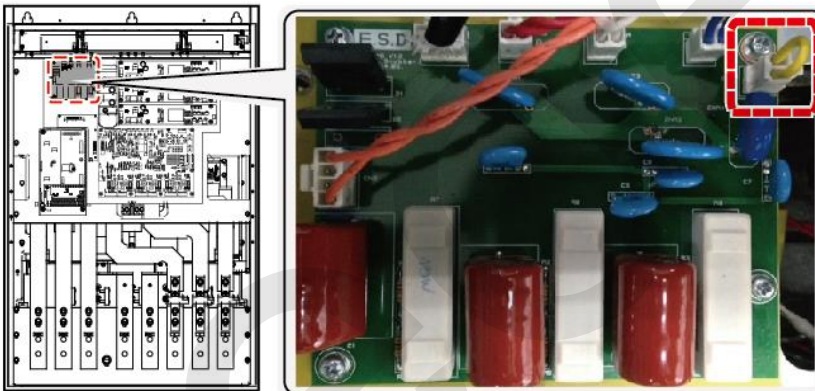

SV2800-3750iS7 (400 V)

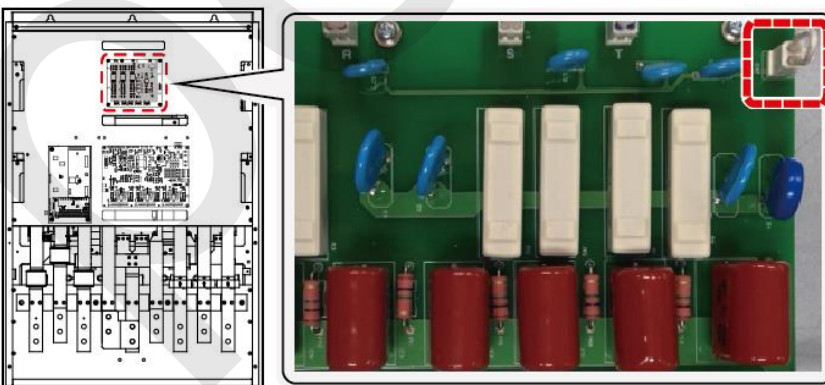

## 4.17 Post-Installation Checklist

After completing the installation, check the items in the following table to make sure that the inverter has been safely and correctly installed.

| Items  | Check Point   | Result |
|--|---|--------|
| Installation Location/Power I/O Verification | Is the installation location appropriate?   |        |
|  | Does the environment meet the inverter's operating conditions?  |        |
|  | Does the power source match the inverter's rated input?   |        |
|  | Is the inverter's rated output sufficient to supply the equipment?<br>(Certain circumstances will result in degraded performance.)  |        |
| Power Terminal Wiring                        | Is a circuit breaker installed on the input side of the inverter?   |        |
|  | Is the circuit breaker correctly rated?   |        |
|  | Are the power source cables correctly connected to the R/S/T terminals of the inverter?<br>(Caution: connecting the power source to the U/V/W terminals may damage the inverter.)                         |        |
|  | Are the motor output cables connected in the correct phase rotation (U/V/W)?<br>(Caution: motors will rotate in the reverse direction if three-phase cables are not wired in the correct phase rotation.) |        |
|  | Are the cables used in the power terminal connections correctly rated?  |        |
|  | Is the inverter grounded correctly?   |        |
|  | Are the power terminal screws and the ground terminal screws tightened to their specified torques?  |        |
|  | Are the overload protection circuits installed correctly on the motors (if multiple motors are run using one inverter)?   |        |
| Control Terminal Wiring                      | Is the inverter separated from the power source by a magnetic contactor (if a braking resistor is in use)?  |        |
|  | Are advanced-phase capacitors, surge protection, and electromagnetic interference filters installed correctly?<br>(These devices MUST not be installed on the output side of the inverter.)               |        |
|  | Are STP (shielded twisted pair) cables used for control terminal wiring?  |        |
|  | Is the shielding of the STP wiring properly grounded?   |        |
|  | If 3-wire operation is required, are the multi-function input terminals defined prior to the installation of the control wiring connections?  |        |
|  | Are the control cables properly wired?  |        |
| Control Terminal Wiring                      | Are the control terminal screws tightened to their specified torques?   |        |
|  | Is the total cable length of all control wiring < 328 ft (100 m) for model types  |        |

| Items         | Check Point  | Result |
|---------------|--|--------|
|               | rated at 3.7 kW and below, and 984 ft (300 m) for model types rated at more than 3.7 kW? |        |
|               | Is the total length of safety wiring < 100 ft (30 m)?                                    |        |
| Miscellaneous | Are optional modules connected correctly?  |        |
|               | Is there any debris left inside the inverter?  |        |
|               | Are any cables contacting adjacent terminals, creating a potential short circuit risk?   |        |
|               | Are the control terminal connections separated from the power terminal connections?      |        |
|               | Have the capacitors been replaced if they have been in use for > 2 years?                |        |
|               | Has a fuse been installed for the power source?  |        |
|               | Are the connections to the motor separated from other connections?                       |        |

**Note**

STP (Shielded Twisted Pair) cables have a highly conductive, shielded screen around twisted-pair cables. STP cables protect conductors from electromagnetic interference.

## 4.18 Test Run

When you turn on the iS7 inverter for the first time, it starts in Easy Start mode to help you configure the basic parameters required for inverter operation.

### 4.18.1 Entering Easy Start Mode

The inverter starts in Easy Start mode when you turn on the inverter for the first time, or when the inverter is turned on following a parameter initialization.

**Note**

- Before setting the parameter values for a user application, initialize the parameter settings to make sure that the default setting is applied to all parameters.
- If you initialized all parameters after an inverter trip occurred, the inverter starts in Easy Start mode after it is reset, regardless of the pending trip condition.
- Easy Start mode is not available while the inverter is already running.

### 4.18.2 Setting the Basic Parameters in Easy Start Mode

Refer to the following sequence table to understand the Easy Start sequence and configure the basic parameters according to the instructions.

| Sequence              | Instruction  |
|-----------------------|--|
| Start Easy Set        | Select "Yes" to start the inverter in Easy Start mode (select "No" to start the inverter in Monitor mode).         |
| CNF-01 Language Sel   | Select the keypad display language (only English is available at the moment).                                      |
| DRV-14 Motor Capacity | Set the motor capacity. (Ex: 0.75 kW, 1.5 kW)  |
| BAS-11 Pole Number    | Set the number of poles in the motor.  |
| BAS-15 Rated Volt     | Set the rated motor voltage. Set this value to "0 V" if the rated motor voltage is identical to the input voltage. |
| BAS-10 60/50 Hz Sel   | Set the rated motor frequency.   |
| BAS19 AC Input Volt   | Set the inverter input voltage.  |
| DRV-06 Cmd Source     | Set the source of the frequency reference. (Ex: KEYPAD, FX/RX-1, FX/RX-2, etc.)                                    |
| DRV-01 Cmd Frequency  | Set the frequency reference. (Ex: 50 Hz, 60 Hz, etc.)  |

#### Note

While you are in Easy Start mode, you can press the [ESC] key on the keypad to cancel Easy Start mode and enter Monitor mode.

### 4.18.3 Checking the Inverter Operation

#### ⚠ Caution

Using an inverter, you can easily operate a motor at a high speed. Before operating a motor using an inverter, ensure that the set speed is within the motor's rated speed.

Follow the instructions to ensure that the motor operates correctly according to the inverter settings, and adjust the settings if required.

- 1 Set DRV-06 (CMD source) to "0 (KEYPAD)."
- 2 Set DRV-07 (Freq Ref Src) to "0 (Keypad-1)."
- 3 Set DRV-01 (CMD Frequency) to a temporary speed (Ex: 60 Hz).
- 4 Press the FWD key on the keypad, and ensure that the motor is rotating in the correct direction. When the forward command (Fx) is on, the motor should rotate counterclockwise when viewed from the load side of the motor. If the motor rotates in the reverse direction, switch the cables at the U and V terminals.

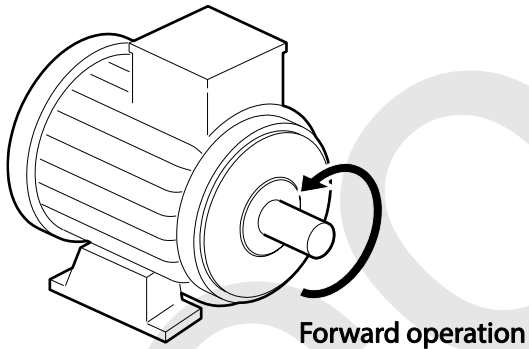

#### ⚠ Caution

Ensure that the input power is within the inverter's rated input voltage range during operation.

## 5 Peripheral Devices

The reference diagram below shows a typical system configuration showing the inverter and peripheral devices.

Prior to installing the inverter, ensure that the product is suitable for the application (power rating, capacity, etc.). Also, ensure that all of the required peripherals and optional devices (resistor brakes, contactors, noise filters, etc.) are available.

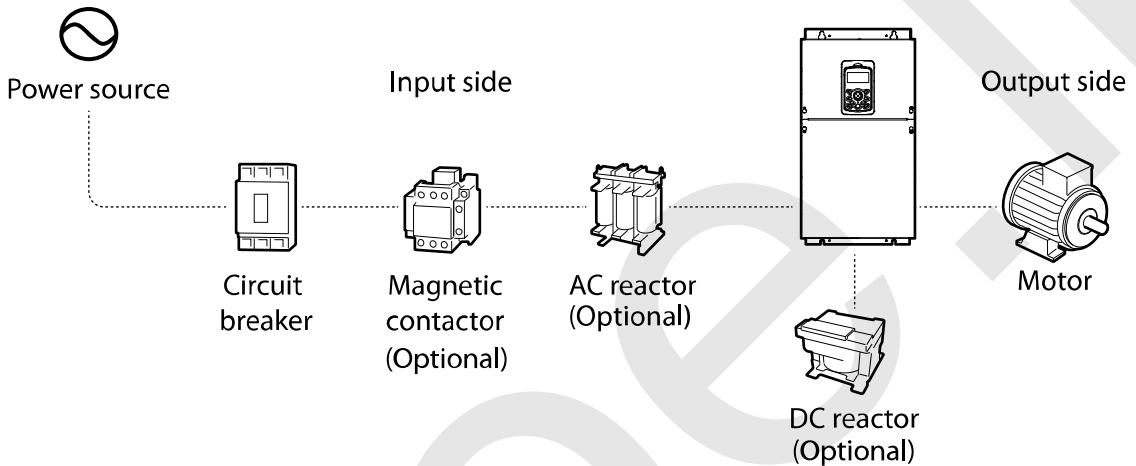

### ⚠ Caution

- Figures in this manual are shown with covers or circuit breakers removed to show a more detailed view of the installation arrangements. Install covers and circuit breakers before operating the inverter. Operate the product according to the instructions in this manual.
- Supply input power within the voltage range approved for the inverter's rating.
- Do not start or stop the inverter using a magnetic contactor installed in the input power supply.
- If the inverter is damaged and loses control, the machine may cause a dangerous situation. Install an additional safety device, such as an emergency brake, to prevent these situations.
- High levels of current draw during power-on can affect the system. Ensure that correctly rated circuit breakers are installed to operate safely during power-on situations.
- Reactors can be installed to improve the power factor. Note that reactors may be installed within 32.8 ft (10 m) of the power source if the input power exceeds 1000 kVA.
- 400 V class inverters require a motor with reinforced insulation. Micro surge voltages generated at the motor terminals may deteriorate the motor insulation.

## 5.1 Wiring Switch, Electronic Contactor, and Reactor Specifications

### 5.1.1 Wiring Switch, Short Circuit Switch, and Electronic Contactor

| Inverter Capacity | Wiring Switch |                  |        |                  | Short Circuit Switch |                  | Electronic Contactor |                  |
|-------------------|---------------|------------------|--------|------------------|----------------------|------------------|----------------------|------------------|
|                   | METASOL       |                  | SUSOL  |                  | Model                | Rated current[A] | Model                | Rated current[A] |
|                   | Model         | Rated current[A] | Model  | Rated current[A] |                      |                  |                      |                  |
| 0008iS7-2         | ABS33c        | 15               | UTE100 | 15               | EBS33c               | 15               | MC-9b                | 11               |
| 0015iS7-2         | ABS33c        | 15               | UTE100 | 15               | EBS33c               | 15               | MC-12b               | 13               |
| 0022iS7-2         | ABS33c        | 30               | UTE100 | 30               | EBS33c               | 30               | MC-18b               | 18               |
| 0037iS7-2         | ABS33c        | 30               | UTE100 | 30               | EBS33c               | 30               | MC-32a               | 32               |
| 0055iS7-2         | ABS53c        | 50               | UTS150 | 50               | EBS53c               | 50               | MC-40a               | 40               |
| 0075iS7-2         | ABS63c        | 60               | UTS150 | 60               | EBS63c               | 60               | MC-50a               | 55               |
| 0110iS7-2         | ABS103c       | 100              | UTS150 | 100              | EBS103c              | 100              | MC-65a               | 65               |
| 0150iS7-2         | ABS103c       | 125              | UTS150 | 125              | EBS203c              | 125              | MC-100a              | 105              |
| 0185iS7-2         | ABS203c       | 150              | UTS150 | 150              | EBS203c              | 150              | MC-130a              | 130              |
| 0220iS7-2         | ABS203c       | 175              | UTS250 | 175              | EBS203c              | 175              | MC-150a              | 150              |
| 0300iS7-2         | ABS203c       | 225              | UTS250 | 225              | EBS203c              | 225              | MC-150a              | 150              |
| 0370iS7-2         | ABS403c       | 300              | UTS400 | 300              | EBS403c              | 300              | MC-225a              | 225              |
| 0450iS7-2         | ABS403c       | 350              | UTS400 | 350              | EBS403c              | 350              | MC-330a              | 330              |
| 0550iS7-2         | ABS603c       | 500              | UTS600 | 500              | EBS603c              | 500              | MC-400a              | 400              |
| 0750iS7-2         | ABS603c       | 630              | UTS600 | 600              | EBS603c              | 630              | MC-630a              | 630              |
| 0008iS7-4         | ABS33c        | 15               | UTE100 | 15               | EBS33c               | 15               | MC-9b                | 9                |
| 0015iS7-4         | ABS33c        | 15               | UTE100 | 15               | EBS33c               | 15               | MC-9b                | 9                |
| 0022iS7-4         | ABS33c        | 15               | UTE100 | 15               | EBS33c               | 15               | MC-12b               | 12               |
| 0037iS7-4         | ABS33c        | 15               | UTE100 | 15               | EBS33c               | 15               | MC-18b               | 18               |
| 0055iS7-4         | ABS33c        | 30               | UTE100 | 30               | EBS33c               | 30               | MC-22b               | 22               |
| 0075iS7-4         | ABS33c        | 30               | UTE100 | 30               | EBS33c               | 30               | MC-32a               | 32               |
| 0110iS7-4         | ABS53c        | 50               | UTS150 | 50               | EBS53c               | 50               | MC-40a               | 40               |
| 0150iS7-4         | ABS63c        | 60               | UTS150 | 60               | EBS63c               | 60               | MC-50a               | 50               |
| 0185iS7-4         | ABS103c       | 80               | UTS150 | 80               | EBS103c              | 75               | MC-65a               | 65               |
| 0220iS7-4         | ABS103c       | 100              | UTS150 | 100              | EBS103c              | 100              | MC-65a               | 65               |
| 0300iS7-4         | ABS103c       | 125              | UTS150 | 125              | EBS203c              | 125              | MC-100a              | 105              |
| 0370iS7-4         | ABS203c       | 150              | UTS150 | 150              | EBS203c              | 150              | MC-130a              | 130              |
| 0450iS7-4         | ABS203c       | 175              | UTS250 | 175              | EBS203c              | 175              | MC-150a              | 150              |
| 0550iS7-4         | ABS203c       | 225              | UTS250 | 225              | EBS203c              | 225              | MC-185a              | 185              |
| 0750iS7-4         | ABS403c       | 300              | UTS400 | 300              | EBS403c              | 300              | MC-225a              | 225              |
| 0900iS7-4         | ABS403c       | 400              | UTS400 | 400              | EBS403c              | 400              | MC-330a              | 330              |
| 1100iS7-4         | ABS603c       | 500              | UTS600 | 500              | EBS603c              | 500              | MC-400a              | 400              |
| 1320iS7-4         | ABS603c       | 630              | UTS600 | 600              | EBS603c              | 630              | MC-400a              | 400              |
| 1600iS7-4         | ABS603c       | 630              | UTS600 | 600              | EBS603c              | 630              | MC-630a              | 630              |
| 1850iS7-4         | ABS803c       | 800              | UTS800 | 800              | EBS803c              | 800              | MC-630a              | 630              |



| Inverter Capacity | Wiring Switch |                  |         |                  | Short Circuit Switch |                  | Electronic Contactor |                  |
|-------------------|---------------|------------------|---------|------------------|----------------------|------------------|----------------------|------------------|
|                   | METASOL       |                  | SUSOL   |                  |                      |                  |                      |                  |
|                   | Model         | Rated current[A] | Model   | Rated current[A] | Model                | Rated current[A] | Model                | Rated current[A] |
| 2200iS7-4         | ABS803c       | 800              | UTS800  | 800              | EBS803c              | 800              | MC-800a              | 800              |
| 2800iS7-4         | ABS1003b      | 1000             | UTS1200 | 1000             | EBS1003c             | 1000             | 1000A                | 1000             |
| 3150iS7-4         | ABS1203b      | 1200             | UTS1200 | 1200             | EBS1203c             | 1200             | 1200A                | 1200             |
| 3750iS7-4         | 1400A         | 1400             | 1400A   | 1400             | 1400A                | 1400             | 1400A                | 1400             |

### ⚠ Caution

Only use Class H or RK5 UL listed input fuses and UL listed breakers. See the table above for the voltage and current ratings for the fuses and breakers.

Utiliser UNIQUEMENT des fusibles d'entrée homologués de Classe H ou RK5 UL et des disjoncteurs UL. Se reporter au tableau ci-dessus pour la tension et le courant nominal des fusibles et des disjoncteurs.

### Note

- If you install the recommended reactors, you can maintain the power factor above 85%, and keep the THD below 40% for operations at the rated load. Improvements are reduced at lighter loads.
- Cable impedance affects the input power factor and occurrence of harmonic waves. The input power factor and THD improvement of the reactors may be lower depending on the transformer capacity, the transformer impedance, and the cable length.
- Refer to the specifications table and install recommended reactors. Although a higher inductance value (L) of the reactor results in an improvement in the power factor and better suppression of harmonic effects, power loss increases at the same time due to voltage drop.
- The capacity of built-in DC reactors in some iS7 inverter models is based on the normal duty load factor. Therefore, improvements may be reduced during a heavy duty operation.

## 5.1.2 Reactors

### DC Reactor Specifications

The iS7 200 V/ 400 V 30–75 kW, 400 V/280–375 kW models are not supplied with a built-in DC reactor. Refer to the following specifications tables for different models to choose an appropriate DC reactor for your application.

#### <200V/30–75kW>

| Inverter capacity | DC reactor specifications |     |
|-------------------|---------------------------|-----|
|                   | mH                        | A   |
| 0300iS7-2         | 0.24                      | 200 |
| 0370iS7-2         | 0.2                       | 240 |
| 0450iS7-2         | 0.17                      | 280 |
| 0550iS7-2         | 0.12                      | 360 |
| 0750iS7-2         | 0.1                       | 500 |

#### <400V/30–75kW>

(For Non-DCR products, remove the P1 and P2 shorting pins to install the DC reactor.)

| Inverter capacity | DC reactor specifications |     |
|-------------------|---------------------------|-----|
|                   | mH                        | A   |
| 0300iS7-4         | 0.98                      | 75  |
| 0370iS7-4         | 0.87                      | 90  |
| 0450iS7-4         | 0.55                      | 110 |
| 0550iS7-4         | 0.47                      | 150 |
| 0750iS7-4         | 0.48                      | 180 |

#### <400V/280–375 kW>

| Inverter capacity | DC reactor specifications |      |
|-------------------|---------------------------|------|
|                   | mH                        | A    |
| 2800iS7-4         | 0.09                      | 836  |
| 3150iS7-4         | 0.076                     | 996  |
| 3750iS7-4         | 0.064                     | 1195 |

### Note

All iS7 models, other than the 200 V/30–75 kW and 400 V/280–375 kW models, may be provided with an optional built-in DC reactor.

### AC Reactor Specifications

You can install an AC reactor to prevent the capacitors and generators from overheating or being damaged when the power source voltage is unbalanced.

When you install an AC reactor, connect the AC reactor cables to the R, S, and T terminals on the inverter. Installation of an AC reactor is not necessary if a DC reactor is already installed in the inverter.

To avoid power loss resulting from the incorrect installation of an AC reactor, contact LS ELECTRIC Customer Support to ensure that your model type and application requires the installation of an AC reactor.

Refer to the following specifications tables to choose an appropriate AC reactor for your application.

| Inverter capacity | AC reactor specifications |     |             |     |
|-------------------|---------------------------|-----|-------------|-----|
|                   | Heavy duty                |     | Normal duty |     |
|                   | mH                        | A   | mH          | A   |
| 0008iS7-2         | 2.13                      | 5.7 | 1.20        | 10  |
| 0015iS7-2         | 1.20                      | 10  | 0.88        | 14  |
| 0022iS7-2         | 0.88                      | 14  | 0.56        | 20  |
| 0037iS7-2         | 0.56                      | 20  | 0.39        | 30  |
| 0055iS7-2         | 0.39                      | 30  | 0.28        | 40  |
| 0075iS7-2         | 0.28                      | 40  | 0.20        | 59  |
| 0110iS7-2         | 0.20                      | 59  | 0.15        | 75  |
| 0150iS7-2         | 0.15                      | 75  | 0.12        | 96  |
| 0185iS7-2         | 0.12                      | 96  | 0.10        | 112 |
| 0220iS7-2         | 0.10                      | 112 | 0.07        | 160 |
| 0300iS7-2         | 0.07                      | 160 | 0.05        | 200 |
| 0370iS7-2         | 0.05                      | 200 | 0.044       | 240 |
| 0450iS7-2         | 0.044                     | 240 | 0.038       | 280 |
| 0550iS7-2         | 0.038                     | 280 | 0.026       | 360 |
| 0750iS7-2         | 0.026                     | 360 | 0.02        | 500 |
| 0008iS7-4         | 8.63                      | 2.8 | 4.81        | 4.8 |
| 0015iS7-4         | 4.81                      | 4.8 | 3.23        | 7.5 |
| 0022iS7-4         | 3.23                      | 7.5 | 2.34        | 10  |
| 0037iS7-4         | 2.34                      | 10  | 1.22        | 15  |
| 0055iS7-4         | 1.22                      | 15  | 1.14        | 20  |
| 0075iS7-4         | 1.14                      | 20  | 0.81        | 30  |

| Inverter capacity | AC reactor specifications |     |             |     |
|-------------------|---------------------------|-----|-------------|-----|
|                   | Heavy duty                |     | Normal duty |     |
|                   | mH                        | A   | mH          | A   |
| 0110iS7-4         | 0.81                      | 30  | 0.61        | 38  |
| 0150iS7-4         | 0.61                      | 38  | 0.45        | 50  |
| 0185iS7-4         | 0.45                      | 50  | 0.39        | 58  |
| 0220iS7-4         | 0.39                      | 58  | 0.287       | 80  |
| 0300iS7-4         | 0.287                     | 80  | 0.232       | 98  |
| 0370iS7-4         | 0.232                     | 98  | 0.195       | 118 |
| 0450iS7-4         | 0.195                     | 118 | 0.157       | 142 |
| 0550iS7-4         | 0.157                     | 142 | 0.122       | 196 |
| 0750iS7-4         | 0.122                     | 196 | 0.096       | 237 |
| 0900iS7-4         | 0.096                     | 237 | 0.081       | 289 |
| 1100iS7-4         | 0.081                     | 289 | 0.069       | 341 |
| 1320iS7-4         | 0.069                     | 341 | 0.057       | 420 |
| 1600iS7-4         | 0.057                     | 420 | 0.042       | 558 |
| 1850iS7-4         | 0.042                     | 558 | 0.042       | 558 |
| 2200iS7-4         | 0.042                     | 558 | 0.029       | 799 |
| 2800iS7-4         | 0.029                     | 799 | 0.029       | 799 |
| 3150iS7-4         | 0.029                     | 799 | 0.024       | 952 |
| 3750iS7-4         | 0.024                     | 952 | 0.024       | 952 |

### 5.1.3 Dynamic Braking Unit (DBU) and Resistor

#### Dynamic Braking Unit Specifications

| UL form     | Voltage                  | Capacity of applied motor | Braking unit       | Reference-Terminal arrangement & dimensions |
|-------------|--------------------------|---------------------------|--------------------|---|
| UL type     | 200 V                    | 30–37 kW                  | SV370DBU-2U        | Group 1                                     |
|             |                          | 45–55 kW                  | SV550DBU-2U        |   |
|             |                          | 75 kW                     | SV370DBU-2U, 2Set  |   |
|             | 400 V                    | 30–37 kW                  | SV370DBU-4U        |   |
|             |                          | 45–55 kW                  | SV550DBU-4U        |   |
|             |                          | 75 kW                     | SV750DBU-4U        |   |
|             |                          | 90 kW                     | SV550DBU-4U, 2Set  |   |
| 110–132 kW  |                          | SV750DBU-4U, 2Set         |                    |   |
| 160 kW      | SV750DBU-4U, 3Set        |                           |                    |   |
| Non UL type | 400 V                    | 45–55 kW,<br>75 kW        | SV075DB-4          | Group 3                                     |
|             |                          | 185–220 kW                | SV2200DB-4 Note 1) | Group 4                                     |
|             |                          | 280–375 Kw                | SV2200DB-4, 2Set   |   |
|             | 200 V                    | 30–37 kW                  | LSLV0370DBU-2LN    | Group 5                                     |
|             |                          |                           | LSLV0370DBU-2HN    | Group 6                                     |
|             |                          | 45–55 kW,<br>75 kW        | LSLV0750DBU-2LN    | Group 5                                     |
|             |                          |                           | LSLV0750DBU-2HN    | Group 6                                     |
|             | 400 V                    | 30–37 kW                  | LSLV0370DBU-4LN    | Group 5                                     |
|             |                          |                           | LSLV0370DBU-4HN    | Group 6                                     |
|             |                          | 45–55 kW,<br>75 kW        | LSLV0750DBU-4LN    | Group 5                                     |
|             |                          |                           | LSLV0750DBU-4HN    | Group 6                                     |
|             |                          | 90 kW                     | LSLV0900DBU-4HN    | Group 6                                     |
|             |                          | 110–132 kW                | LSLV1320DBU-4HN    |   |
|             |                          | 160 kW                    | LSLV1600DBU-4HN    |   |
| 185–220 kW  | LSLV2200DBU-4HN          |                           |                    |   |
| 280–375 kW  | LSLV2200DBU-4HN,<br>2Set |                           |                    |   |

Note 1) For model types with a rated capacity of 180 kW and above, contact LS ELECTRIC Customer Support for detailed information.

**Note**

- The 0.75–22kW (200 V/400 V) models are provided with a built-in dynamic braking unit. Installation of additional dynamic braking units is not necessary for these models.
- Refer to the instruction manual provided by the manufacturer before installing a dynamic braking unit. There may be specification changes that are not reflected in the table provided with this manual.
- For detailed specifications of UL type DB units, such as resistance/wattage/braking torque/%ED, refer to the table in [5.1.6 DB Resistors](#) on page [102](#). For non UL type DB units, refer to the instruction manual provided by the manufacturer.

**DBU Terminal Arrangement**

| Group 1 |   |   |    |    | Group 2 |   |    |      |
|---------|---|---|----|----|---------|---|----|------|
| P       | N | G | B1 | B2 | G       | N | B2 | P/B1 |

| Terminal | Description                                       |
|----------|---|
| G        | Ground Terminal                                   |
| B2       | Connect to the B2 terminal of a braking resistor. |
| B1       | Connect to the B1 terminal of a braking resistor. |
| N        | Connect to the N terminal of an inverter.         |
| P        | Connect to the P1 terminal of an inverter.        |

## Group 3 (75 kW DB unit)

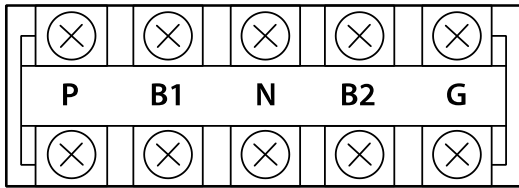

## Group 4 (220 kW DB unit)

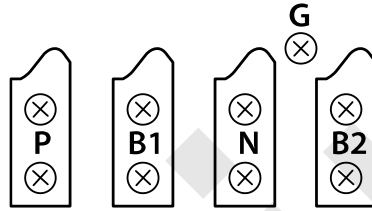

| Terminal | Description                                       |
|----------|---|
| G        | Ground Terminal                                   |
| B2       | Connect to the B2 terminal of a braking resistor. |
| B1       | Connect to the B1 terminal of a braking resistor. |
| N        | Connect to the N terminal of an inverter.         |
| P        | Connect to the P terminal of an inverter.         |

## Group 5

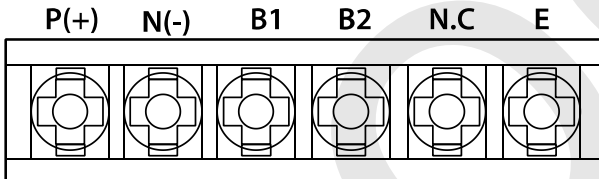

| Terminal | Description                                       |
|----------|---|
| P (+)    | Connect to the P terminal of an inverter.         |
| N (-)    | Connect to the N terminal of an inverter.         |
| B1       | Connect to the B1 terminal of a braking resistor. |
| B2       | Connect to the B2 terminal of a braking resistor. |
| N.C      | Not used  |
| E        | Ground terminal                                   |

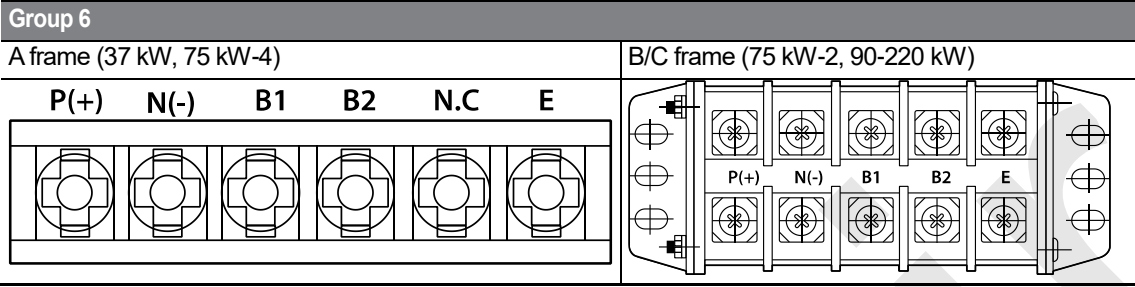

| Terminal | Description   |
|----------|---|
| P (+)    | Connect to the P terminal of an inverter (DC bus).          |
| N (-)    | Connect to the N terminal of an inverter (DC bus).          |
| B1       | Connect to the B1 terminal of an external braking resistor. |
| B2       | Connect to the B2 terminal of an external braking resistor. |
| N.C      | Not used  |
| E        | Ground terminal   |

**Note**

Refer to the instruction manual that is supplied with the DB unit to choose appropriate DB resistors for installation.

**Basic Wiring Connection for the DB Unit and DB Resistor**

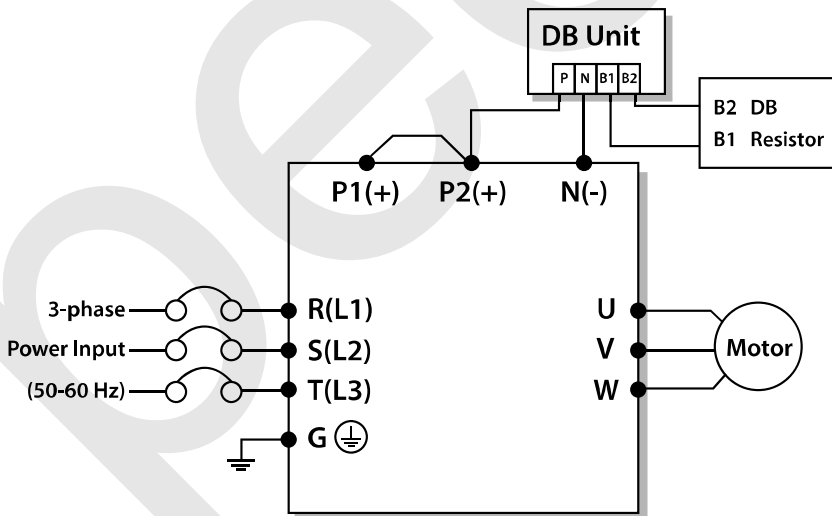

| DB Unit Terminal | Description |
|------------------|-------------|
|------------------|-------------|



| DB Unit Terminal | Description                                  |
|------------------|--|
| B1               | Connect to the B1 terminal of a DB resistor. |
| B2               | Connect to the B2 terminal of a DB resistor. |

### 5.1.4 DB Unit Dimensions

#### Group 1

M4–M5 Mounting

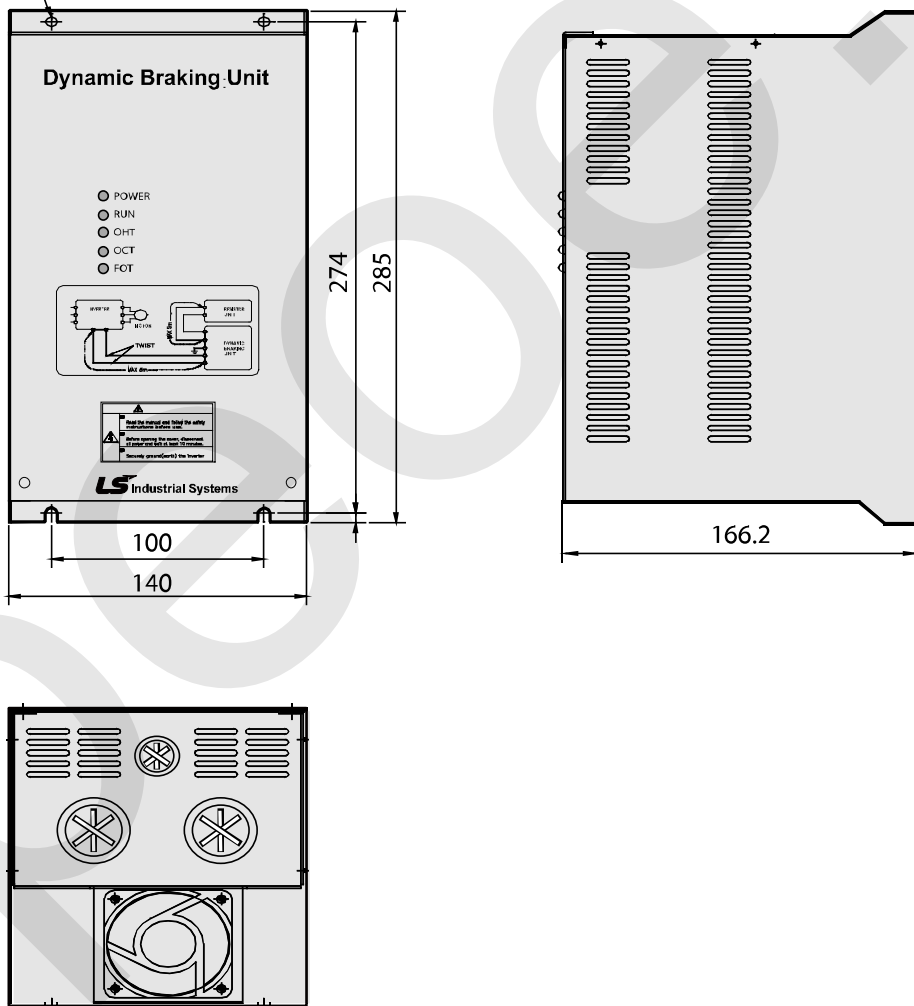

Group 2

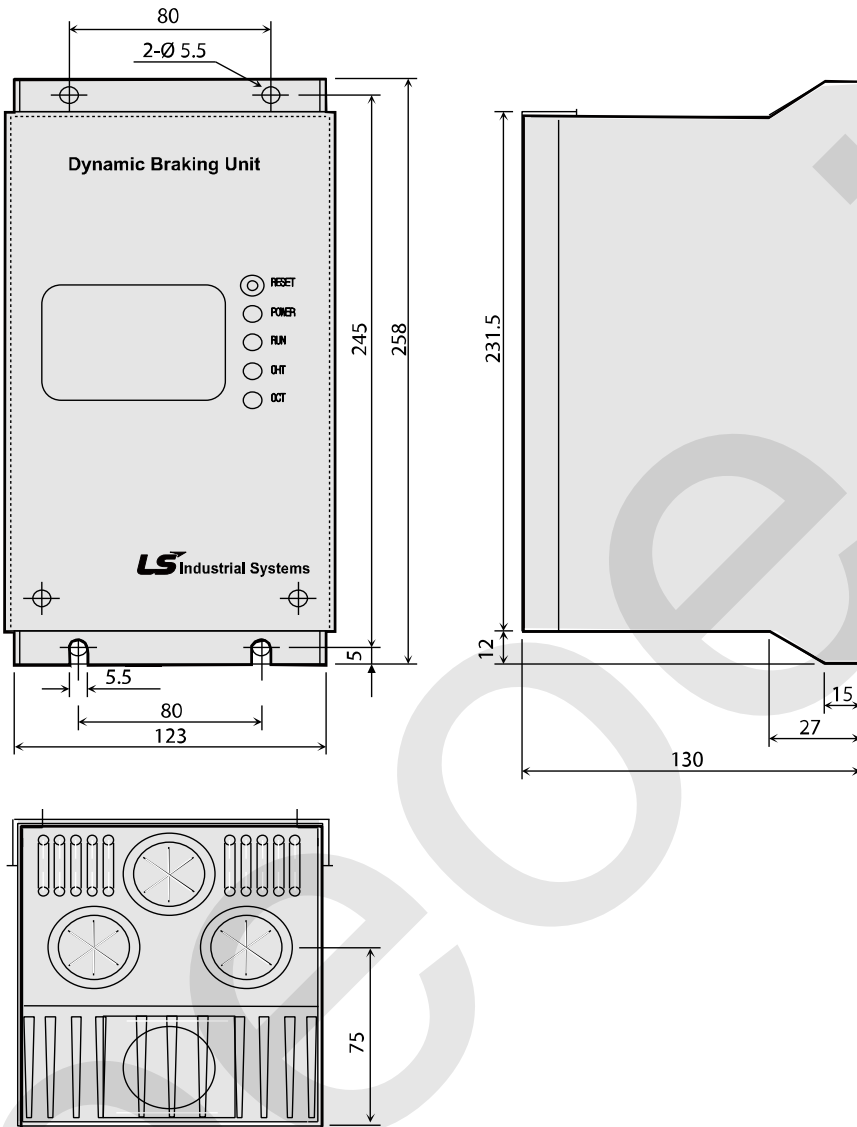

## Group 3

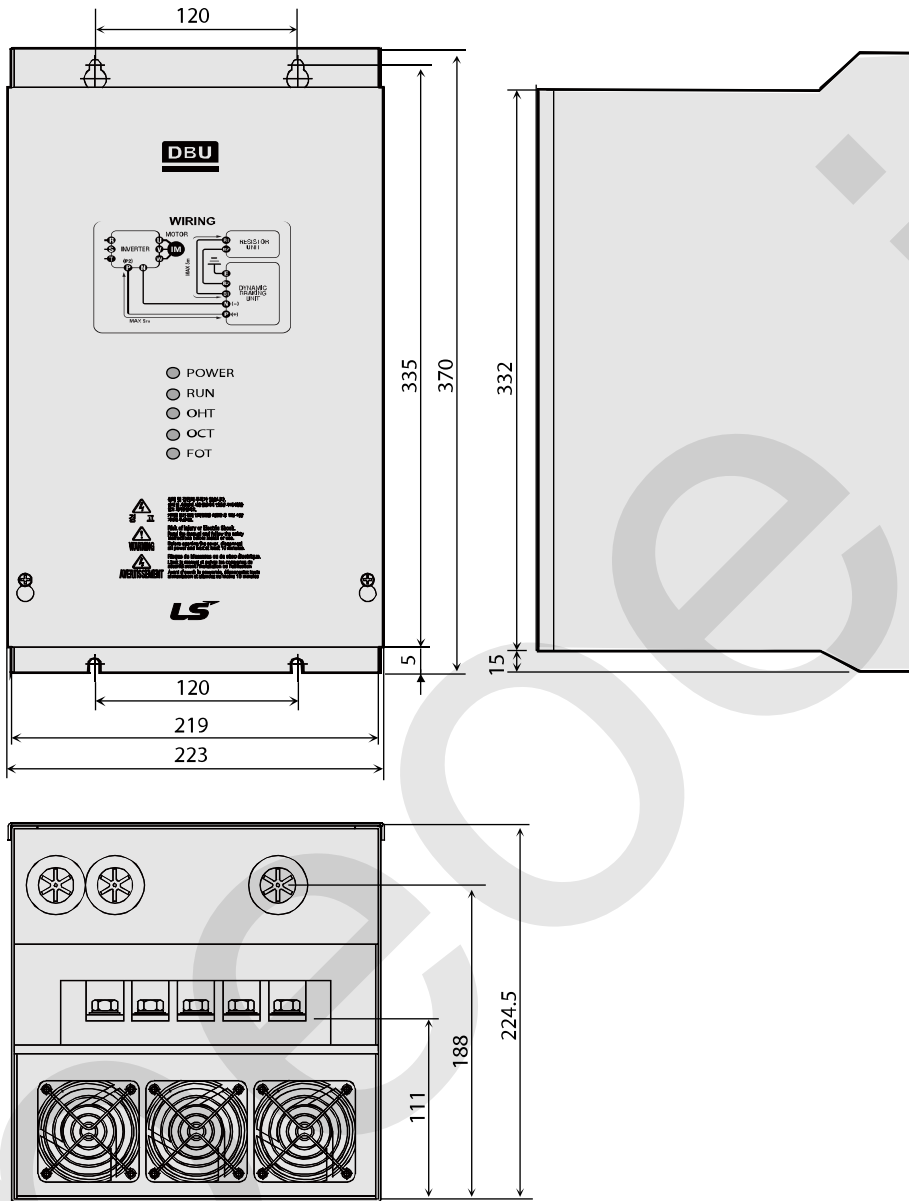

Group 4

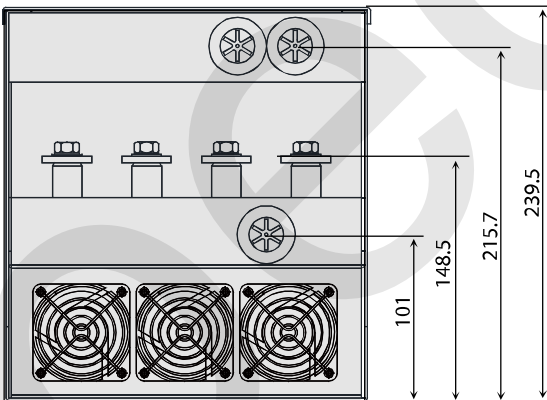
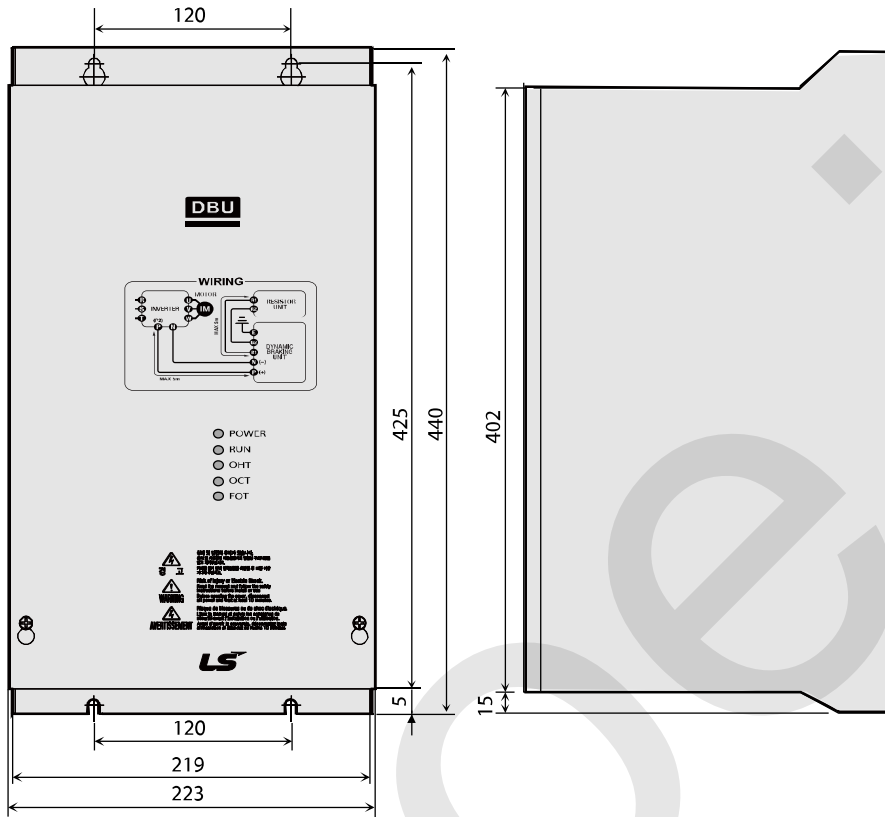

Group 5

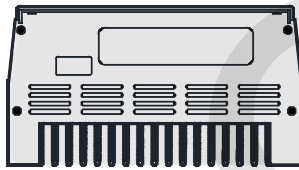
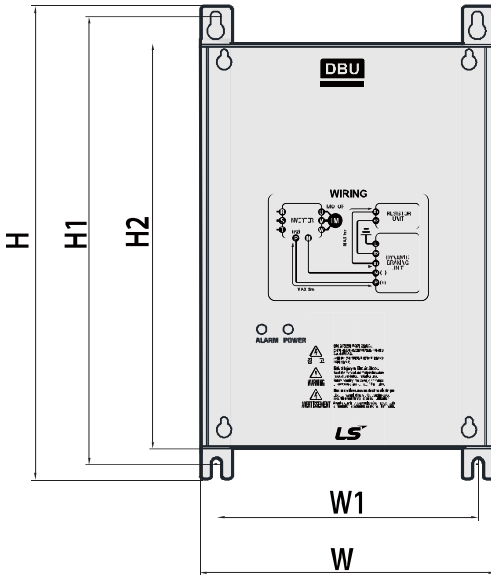

| Voltage | Motor capacity | Dimensions (mm) |       |     |      | Hole position |       | Weight | Hole size |
|---------|----------------|-----------------|-------|-----|------|---------------|-------|--------|-----------|
|         |                | W               | H     | H2  | D    | W1            | H1    |        |           |
| 220     | 15             | 140             | 227.4 | 192 | 76.4 | 125           | 215.4 | 1.50   | M4        |
|         | 22             |                 |       |     |      |               |       | 1.55   |           |
|         | 37             |                 |       |     |      |               |       | 1.57   |           |
|         | 75             |                 |       |     |      |               |       | 1.84   |           |
| 440     | 15             |                 |       |     |      |               |       | 1.53   |           |
|         | 22             |                 |       |     |      |               |       | 1.55   |           |
|         | 37             |                 |       |     |      |               |       | 1.56   |           |
|         | 75             |                 |       |     |      |               |       | 1.85   |           |

Group 6

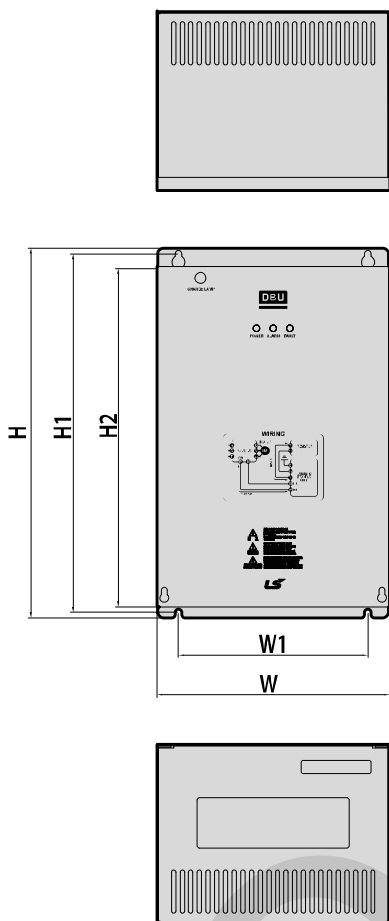

Peripheral  
Devices

| Frame | Voltage | Motor capacity | %ED | Dimensions (mm) |     |     |       | Hole position |       | Weight | Hole size |
|-------|---------|----------------|-----|-----------------|-----|-----|-------|---------------|-------|--------|-----------|
|       | [V]     | [kW]           |     | W               | H   | H2  | D     | W1            | H1    | [kg]   | (φ)       |
| A     | 220     | 37             | 50  | 200             | 219 | 190 | 165.2 | 160           | 208.5 | 3.77   | M6        |
|       | 440     | 37             | 50  |                 |     |     |       |               |       | 3.84   |           |
|       |         | 75             | 50  |                 |     |     |       |               |       | 3.98   |           |
| B     | 220     | 75             | 50  | 215             | 340 | 311 |       | 175           | 329.5 | 8.26   |           |
|       |         | 90             | 50  |                 |     |     |       |               |       | 8.48   |           |
|       | 440     | 90             | 50  |                 |     |     |       |               |       | 8.30   |           |
|       |         | 132            | 50  |                 |     |     |       |               |       | 8.40   |           |
| C     | 440     | 160            | 50  | 240             | 380 | 351 |       | 200           | 369.5 | 9.40   |           |
|       |         | 220            | 50  |                 |     |     |       |               |       | 9.70   |           |

### 5.1.5 Indicators on the DB unit

On a DB unit, there are three LED indicators (one red and two green indicators) that indicate the operating condition of the DB unit.

| Indicator name  | Color | Location | Description  |
|-----------------|-------|----------|--|
| Power indicator | Red   | Middle   | Turns on when the main power is supplied to the unit (if a DB unit is connected to an inverter, the power indicator is turned on when the main power is supplied to the inverter).   |
| RUN indicator   | Green | Right    | Turns on when the DB unit is regenerating.   |
| OHT indicator   | Green | Left     | Turns on when the overheating protection function is enabled. If the DB unit temperature exceeds the maximum allowed operating temperature, the overheating protection function is activated to cut off the input to the DB unit (the power indicator on the DB unit is turned off). |

### 5.1.6 DB Resistors

The following table lists type A DB unit specifications for your reference. For type B and type C DB unit specifications, refer to the instruction manuals that are supplied with the DB units.

Before installing a DB resistor, refer to the instruction manuals provided by the manufacturer to choose an appropriate type of DB resistor.

#### Note

When you double the duty cycle (%ED) of a DB unit, the wattage ratings of the optional DB resistor must be doubled accordingly.

|            | Inverter capacity (kW) | Resistance [ohm] | Wattage [W] | Type   | Reference                 | Wiring [mm <sup>2</sup> ]  | Model Type     |   |
|------------|------------------------|------------------|-------------|--------|---------------------------|----------------------------|----------------|---|
| 200V Class | 0.75                   | 150              | 150         | -      | 150% braking torque, 5%ED | 1.25                       | -              |   |
|            | 1.5                    | 60               | 300         | -      |                           | 1.25                       | -              |   |
|            | 2.2                    | 50               | 400         | TYPE 1 |                           | 2.5                        | MCRF400W50     |   |
|            | 3.7                    | 33               | 600         | TYPE 2 |                           | 2.5                        | MCRF600W33     |   |
|            | 5.5                    | 20               | 800         | TYPE 3 |                           | 2.5                        | MCRF800W20     |   |
|            | 7.5                    | 15               | 1200        | TYPE 5 |                           | 4                          | MCRF1200W15    |   |
|            | 11                     | 10               | 2400        | TYPE 6 |                           | 4                          | MCRF-ST2400W10 |   |
|            | 15                     | 8                | 2400        | TYPE 6 |                           | 10                         | MCRF-ST2400W8  |   |
|            | 18.5                   | 5                | 3600        | TYPE 7 |                           | 20                         | MCRF-ST3600W5  |   |
|            | 22                     | 5                | 3600        | TYPE 7 |                           | 20                         | MCRF-ST3600W5  |   |
|            | 30                     | 5                | 5000        | -      |                           | -                          | -              |   |
|            | 37                     | 4.5              | 7000        | -      |                           | 100% braking torque, 10%ED | -              | - |
|            | 45                     | 3.5              | 10000       | -      |                           |                            | -              | - |
|            | 55                     | 3.0              | 15000       | -      |                           |                            | -              | - |
| 75         | 2.5                    | 20000            | -           | -      | -                         |                            |                |   |
| 400V Class | 0.75                   | 600              | 150         | -      | 150% braking torque, 5%ED | 1.25                       | -              |   |
|            | 1.5                    | 300              | 300         | -      |                           | 2                          | -              |   |
|            | 2.2                    | 200              | 400         | TYPE 1 |                           | 2.5                        | MCRF400W200    |   |
|            | 3.7                    | 130              | 600         | TYPE 2 |                           | 2.5                        | MCRF600W130    |   |
|            | 5.5                    | 85               | 1000        | TYPE 4 |                           | 2.5                        | MCRF1000W85    |   |
|            | 7.5                    | 60               | 1200        | TYPE 5 |                           | 2.5                        | MCRF1200W60    |   |
|            | 11                     | 40               | 2000        | TYPE 6 |                           | 2.5                        | MCRF-ST2000W40 |   |
|            | 15                     | 30               | 2400        | TYPE 6 |                           | 4                          | MCRF-ST2400W30 |   |
|            | 18.5                   | 20               | 3600        | TYPE 7 |                           | 6                          | MCRF-ST3600W20 |   |
|            | 22                     | 20               | 3600        | TYPE 7 |                           | 6                          | MCRF-ST3600W20 |   |
|            | 30                     | 16.9             | 6,400       | -      |                           | 100% braking torque, 10%ED | -              | - |
|            | 37                     | 16.9             | 6,400       | -      |                           |                            | -              | - |
|            | 45                     | 11.4             | 9,600       | -      |                           |                            | -              | - |
|            | 55                     | 11.4             | 9,600       | -      |                           |                            | -              | - |
| 75         | 8.4                    | 12,800           | -           | -      | -                         |                            |                |   |
| 90         | 4.5                    | 15,000           | -           | -      | -                         |                            |                |   |
| 110        | 3.5                    | 17,000           | -           | -      | -                         |                            |                |   |
| 132        | 3.0                    | 20,000           | -           | -      | -                         |                            |                |   |
| 160        | 2.5                    | 25,000           | -           | -      | -                         |                            |                |   |
| 185        | 2                      | 30,000           | -           | -      | -                         |                            |                |   |
| 220        | 2                      | 30,000           | -           | -      | -                         |                            |                |   |
| 280        | 1.5                    | 40,000           | -           | -      | -                         |                            |                |   |
| 315        | 1                      | 60,000           | -           | -      | -                         |                            |                |   |



| Inverter capacity (kW) | Resistance [ohm] | Wattage [W] | Type | Reference | Wiring [mm <sup>2</sup> ] | Model Type |
|------------------------|------------------|-------------|------|-----------|---------------------------|------------|
| 375                    | 1                | 60,000      | -    |           | -                         | -          |

### ⓘ Caution

- If you install multiple DB units in parallel, the combined resistance value must match the resistance value in the table above.
- If an appropriate braking resistor type is not listed in the table, find a braking resistor with equivalent resistance and wattage values that are suggested in the table above.

### 5.1.7 DB Resistor Dimensions

#### TYPE 1,2,3,4,5 (Maximum 1200 Watts)

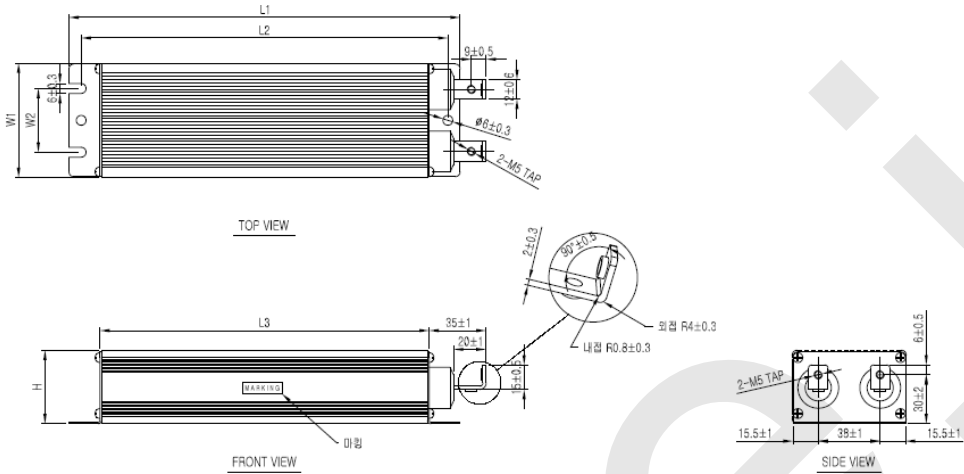

| TYPE | Size [mm] |     |     |    |    |    |
|------|-----------|-----|-----|----|----|----|
|      | W         | H   | D   | A  | B  | C  |
| 1    | 220       | 175 | 152 | 70 | 39 | 45 |
| 2    | 260       | 245 | 222 | 70 | 39 | 45 |
| 3    | 300       | 285 | 262 | 70 | 39 | 45 |
| 4    | 340       | 325 | 302 | 70 | 39 | 45 |
| 5    | 400       | 385 | 362 | 70 | 39 | 45 |

#### TYPE 6 (Maximum 2400 Watts)

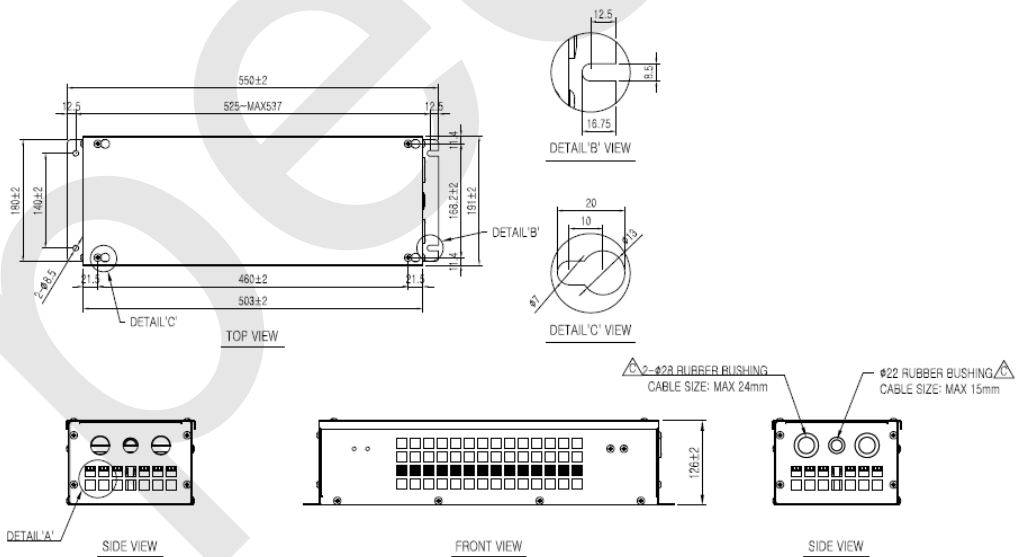

**TYPE 7 (Maximum 3600 Watts)**

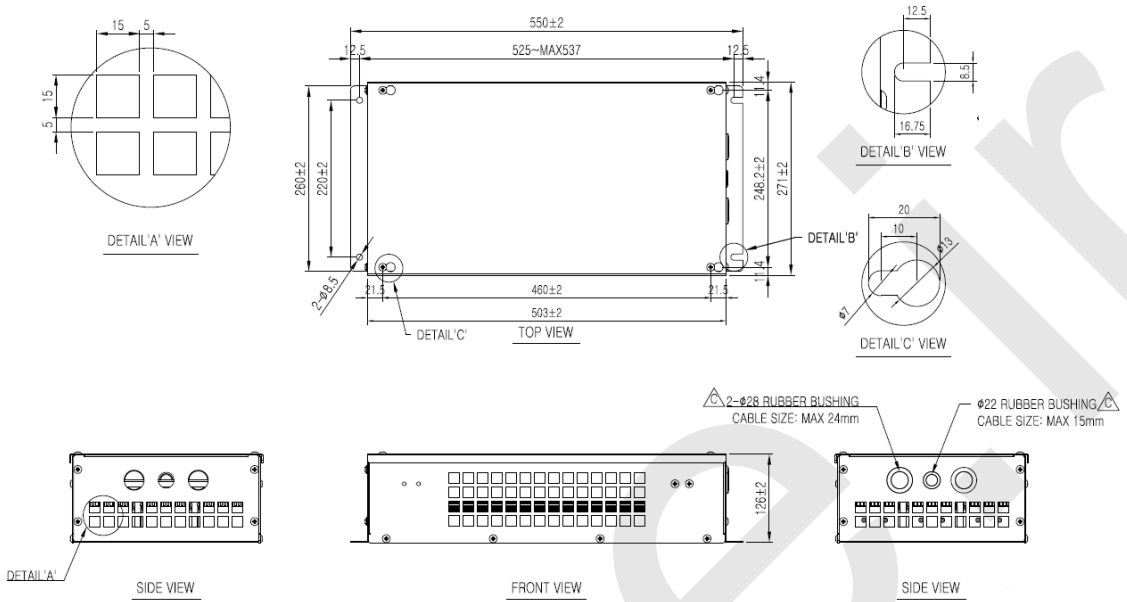

**5.1.8 Keypad Extension Cable for Remote Control (Optional)**

**Included items**

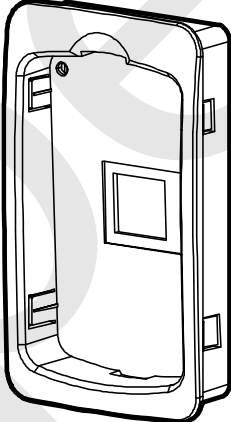
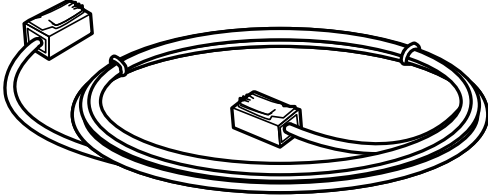
| Items   |  |
|---|--|
|  |  |
| Keypad bracket  | Remote cable (2 m/3 m)   |

### Keypad Bracket Dimensions

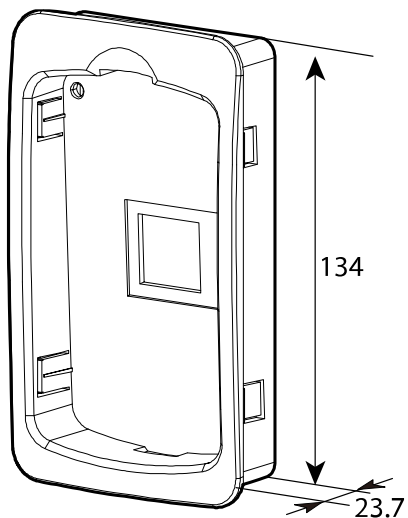

### Remote Cable Specifications

| Model type | Part name                   |
|------------|-----------------------------|
| 64110009   | INV, iS7 REMOTE CABLE (2 M) |
| 64110010   | INV, iS7 REMOTE CABLE (3 M) |

### Installing the Remote Cable

Refer to the following figure to install the remote cable to extend the keypad cable length.

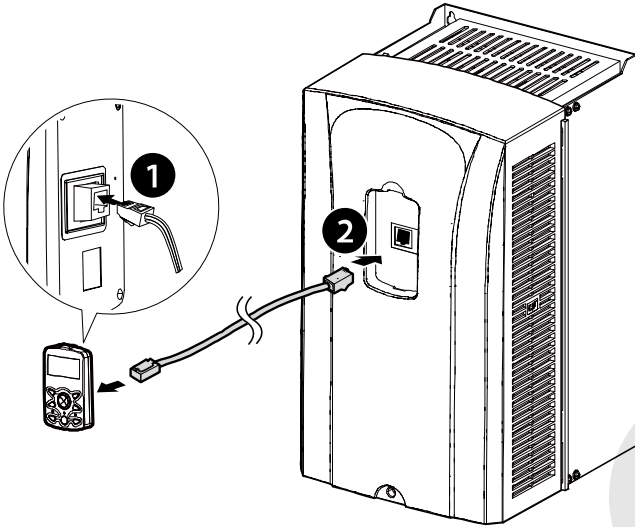

If a “Line Check” message is displayed on the keypad display and the keypad is not operating correctly after installing the remote cable, check the cable connection on both sides.

#### ⚠ Caution

Do not extend the keypad cable using a third-party extension cable. The keypad may not operate correctly due to voltage drop and electromagnetic interference.

#### Note

- Ensure that the cable length between the keypad and the inverter does not exceed 10 ft (3.04 m). Cable connections longer than 10 ft (3.04 m) may cause signal errors.
- Install a ferrite clamp to protect signal cables from electromagnetic interference (Ex. Würth Electronics ferrite clamp PN742732).

## 6 Using the Keypad

### 6.1 About the Keypad

A keypad is used to set inverter parameters, monitor the inverter's status, and operate the inverter.

#### 6.1.1 Dimensions

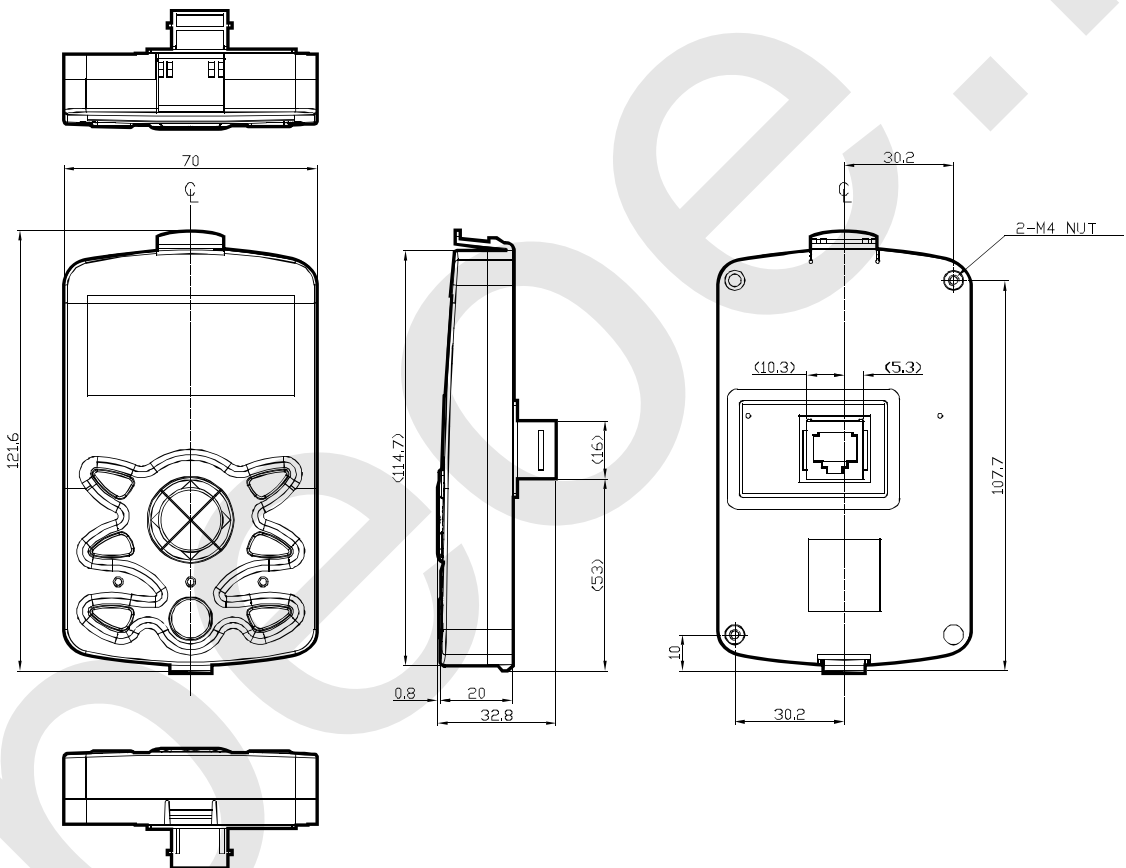

## 6.1.2 Key Functions

The following table lists the names and functions of the keypad's operation keys.

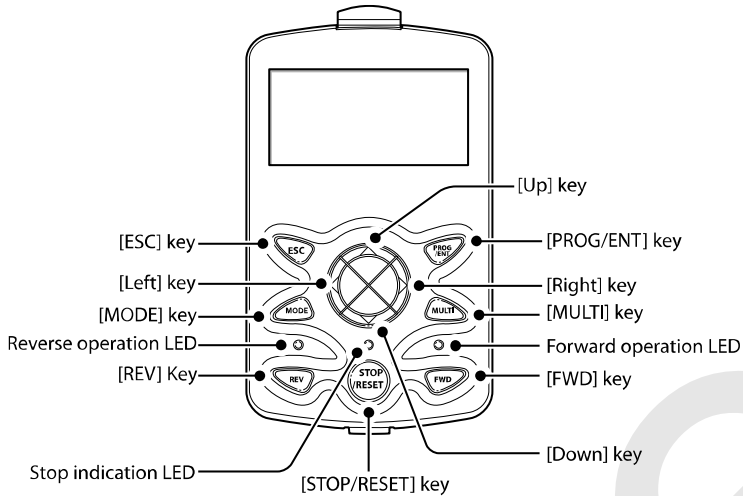

| Section | Buttons          | Key Name  | Function Description   |
|---------|------------------|---|--|
| KEY     |                  | [MODE] key                                      | Used to switch between modes.  |
|         |                  | [PROG/ENT] key                                  | If this button is pressed once, the parameter can be edited at the status of the editable parameter code. If this button is pressed after modification, it will save the modified data.  |
|         |                  | [Up] key  | Switch between codes, or increase or decrease parameter values.  |
|         |                  | [Down] key                                      |  |
|         |                  | [Left] key                                      | Switch between groups or move the cursor during parameter setup or modification.   |
|         |                  | [Right] key                                     |  |
|         |                  | [MULTI] key                                     | Used to register jog or user codes.  |
|         |                  | [ESC] key                                       | If you press this key before pressing the [PROG / ENT] key, it will revert the parameter value to the previous value. If you press this key while editing the codes in any function group, the keypad will display the first code of the function group. If you press this key while moving through the modes, the keypad will display Monitor mode. |
|         |                  | [FWD] key                                       | Used to operate the motor in the forward direction.  |
|         |                  | [REV] key                                       | Used to operate the motor in the reverse direction.  |
|         | [STOP/RESET] key | Used to stop the operation and release a fault. |  |

## 6.1.3 Display Items

### Monitor Mode

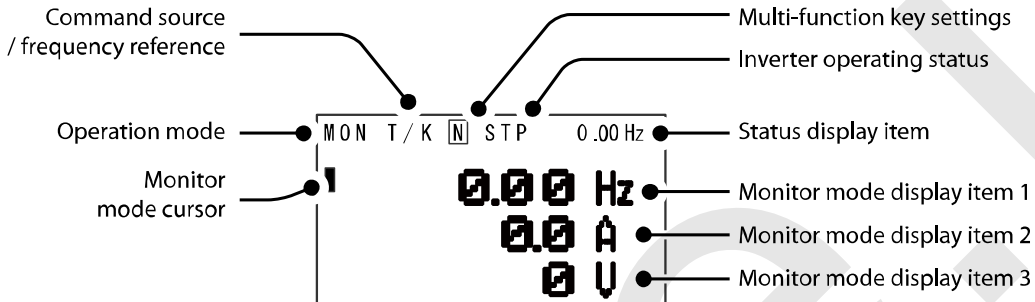

### Parameter Mode

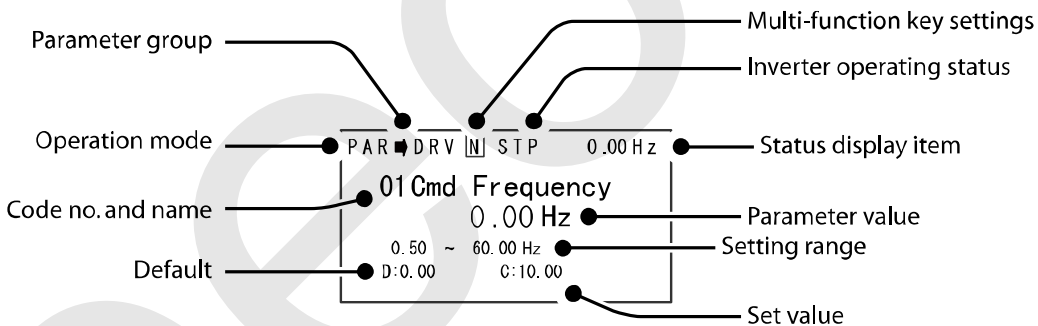

## 6.1.4 Display Item List

The following table lists the items in the display.

| Item                  | Description   |
|-----------------------|---|
| Mode display items    | Displays the current mode's display items. For more details, refer to <a href="#">6.3 Navigating Modes</a> on page 117.                   |
| Parameter group items | Displays the current parameter group's items. For more details, refer to <a href="#">6.4 Navigating Modes and Parameters</a> on page 120. |



| Item                                       | Description  |
|--|--|
| Command source / frequency reference items | Displays the types of sequences and the number of steps during an auto sequence operation.   |
| Status display items                       | Displays the output frequency, output voltage, and current. For more details, refer to <u>0</u> <i>Display Items</i> on pages <u>111</u> . |
| Monitor mode display items                 | Displays the current operation status. For more details, refer to <u>0</u> <i>Display Items</i> on pages <u>111</u> .                      |

### Monitor display items

The following table lists display icons and their names and functions.

| No | Function                    | Display      | Description   |
|----|-----------------------------|--------------|---|
| 1  | Operation mode              | MON          | Monitor mode  |
|    |                             | PAR          | Parameter mode  |
|    |                             | U&M          | User-defined and Macro mode                                 |
|    |                             | TRP          | Trip mode   |
|    |                             | CNF          | Configuration mode  |
| 2  | Command source              | K            | Keypad operation command                                    |
|    |                             | O            | FieldBus communication option operation command             |
|    |                             | A            | Application option operation command                        |
|    |                             | R            | Built-in 485 operation command                              |
|    |                             | T            | Terminal block operation command                            |
| 3  | Frequency reference         | K            | Keypad frequency command                                    |
|    |                             | V            | V1 input frequency command                                  |
|    |                             | I            | I1 input frequency command                                  |
|    |                             | P            | Pulse input frequency command                               |
|    |                             | U            | Frequency command during UP operation (Up-Down operation)   |
|    |                             | D            | Frequency command during DOWN operation (Up-Down operation) |
|    |                             | S            | Frequency command during STOP operation (Up-Down operation) |
|    |                             | O            | FBus Option frequency command                               |
|    |                             | X            | V2 and I2 frequency commands for sub-terminal block         |
|    |                             | J            | Jog frequency command                                       |
|    |                             | R            | Internal 485 frequency command                              |
| 4  | Multi-function key settings | JOG key      | Used to switch to Keypad JOG mode                           |
|    |                             | Local/Remote | Used to select local or remote operation                    |

| No | Function                  | Display               | Description   |
|----|---------------------------|-----------------------|---|
|    |                           | User Group Select key | Used to register parameters as a user group in Parameter mode or delete parameters in the user group. |
| 5  | Inverter operating status | STP                   | Motor stopped   |
|    |                           | FWD                   | Operating in the forward direction  |
|    |                           | REV                   | Operating in the reverse direction  |
|    |                           | DC                    | DC output   |
|    |                           | WAN                   | Warning   |
|    |                           | STL                   | Stalling  |
|    |                           | SPS                   | Speed Search  |
|    |                           | OSS                   | Software over current controlled  |
|    |                           | OSH                   | Hardware over current controlled  |
|    |                           | TUN                   | Auto tuning   |

\*OSS / OSH may cause overcurrent when the load is too large or when the acceleration/deceleration time is short. The inverter monitors the output current so that an overcurrent trip does not occur and also performs overcurrent suppression.

At this time, the output frequency is automatically changed to reduce the output current or the inverter output is temporarily cut off to prevent overcurrent.

## 6.2 Menu Items

The SV-iS7 series inverter uses 5 modes to monitor or configure different functions. Each mode has its own function items suitable for the desired properties. The parameters in Parameter mode and User & Macro mode are divided into smaller groups of relevant functions.

Press the [MODE] key to navigate between groups.

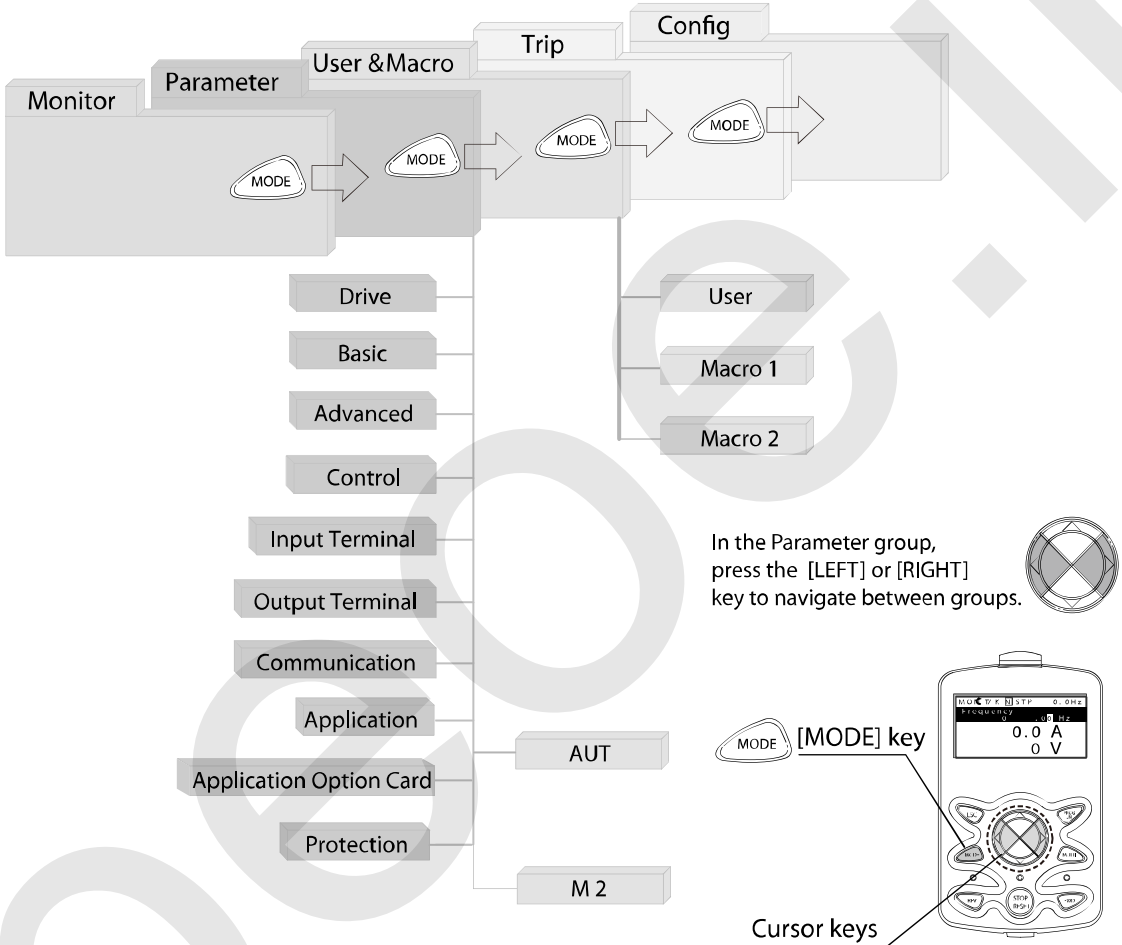

| Mode               | Display | Description   |
|--------------------|---------|---|
| Monitor mode       | MON     | Displays the inverter's operation status information. You can monitor the frequency setting, operating frequency display, output current, voltage, etc.   |
| Parameter mode     | PAR     | Used to configure the functions required to operate the inverter. These functions are divided into 12 groups based on purpose and complexity.   |
| User & Macro mode  | U&M     | Used to define User and Macro groups. These user-definable groups allow specific functions of the inverter to be grouped and managed in separate groups.<br>This mode will not be displayed when navigating through modes if no User groups or Macro groups have been defined.  |
| Trip mode          | TRP     | Used to monitor the inverter's fault trip information, including the previous fault trip history.<br>When a fault trip occurs during inverter operation, the operation frequency, output current, and output voltage of the inverter at the time of the fault can be monitored.<br>This mode will not be displayed if the inverter is not at fault and a fault trip history does not exist. |
| Configuration mode | CNF     | Used to configure the inverter features that are not directly related to the operation of the inverter. The settings you can configure in Configuration mode include keypad display language options, monitor mode environment settings, communication module display settings, and parameter duplication and initialization.   |

## 6.2.1 Parameter Mode

| Mode                           | Display | Description   |
|--------------------------------|---------|---|
| Drive group                    | DRV     | Includes frequency/acceleration/deceleration time setting, operation command selection, etc.                          |
| Basic group                    | BAS     | Configures basic operation parameters. These parameters include motor parameters and multi-step frequency parameters. |
| Advanced function group        | ADV     | Configures acceleration or deceleration, patterns, and frequency limits.  |
| Control function group         | CON     | Configures functions related to sensorless and vector control.  |
| Input terminal function group  | IN      | Configures input terminal-related features, including digital multi-functional inputs and analog inputs.              |
| Output terminal function group | OUT     | Configures the inverter output terminal block-related features, including the relay and analog outputs.               |
| Communication function group   | COM     | Configures the communication features for the RS-485, if one is installed.  |
| Application function group     | APP     | Configures the features related to PID control and auto sequence operation.   |
| Auto Sequence run              | AUT     | Configures the necessary features for auto sequence operation.  |

| Mode                             | Display | Description   |
|----------------------------------|---------|---|
| group                            |         | This group will be displayed if the auto sequence operation in the APP group is selected.   |
| Application option group         | APO     | Configures the encoder and PLC option module-related features if they are installed.  |
| Protection group                 | PRT     | Configures motor and inverter protection features.  |
| Motor 2 function group (Motor 2) | M2      | Configures the secondary motor-related features. This group will be displayed when Motor #2 is selected from the multi-function input terminal functions. |

### 6.2.2 User & Macro Mode

| Group       | Display | Description   |
|-------------|---------|---|
| User group  | USR     | Used to group frequently accessed function parameters. User parameter groups can be configured using the multi-function key on the keypad.  |
| Macro group | MCx     | This provides different factory preset groups of functions based on the type of load. Group MC1, MC2, or MC3 will be displayed when the user selects the desired load type. Macro groups can be selected in CNF mode. For more details, refer to <u>11.12 Parameter Group for Transmission of Macro Group and User Group at U&amp;M Mode</u> on page <u>344</u> . |

## 6.3 Navigating Modes

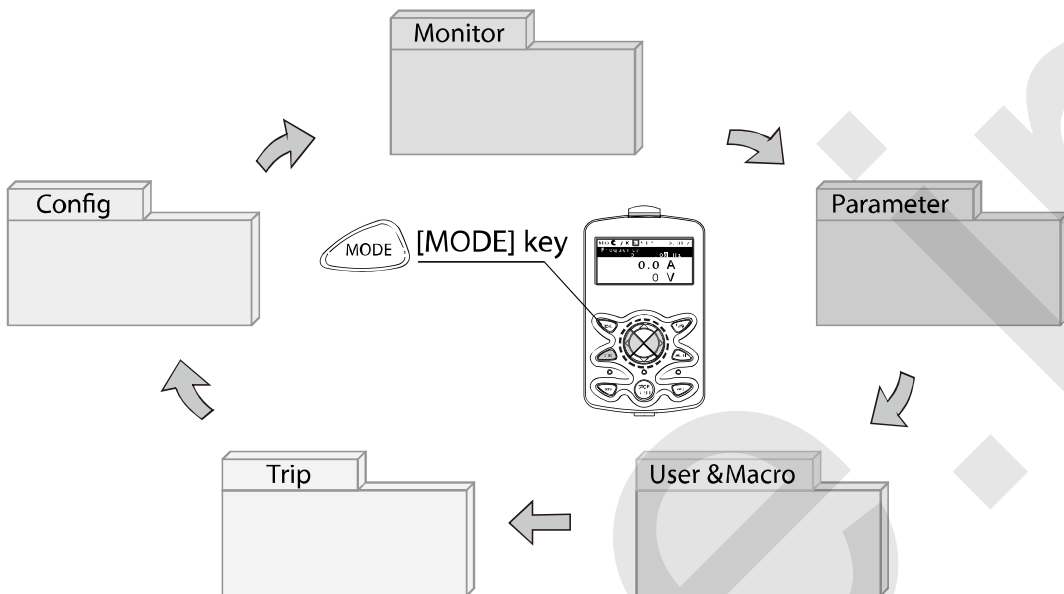

### 6.3.1 Mode Navigation at the Factory Default

You can change the display to navigate modes by using the [MODE] key. The User & Macro Mode and Trip Mode are not displayed when the inverter is set to the factory default settings. For more details, refer to [11.12 Parameter Group for Transmission of Macro Group and User Group at U&M Mode](#) on page [344](#).

|  |   |
|--|---|
|  | <ul style="list-style-type: none"> <li>• Displays when the inverter is powered on. This is the display of Monitor mode (MON).</li> <li>• Press the [MODE] key.</li> </ul> |
|  | <ul style="list-style-type: none"> <li>• You are now in Parameter mode (PAR).</li> <li>• Press the [MODE] key.</li> </ul>   |

|  |  |
|--|--|
|  | <ul style="list-style-type: none"> <li>You are now in Config mode (CNF).</li> <li>Press the [MODE] key.</li> </ul> |
|  | <ul style="list-style-type: none"> <li>You are now in Monitor mode again.</li> </ul>                               |

### 6.3.2 Mode Navigation with User/Macro Mode and Trip Mode

If you register a user code or set the macro function using the [MULTI] key, the User & Macro mode will be displayed, unlike the factory default settings during mode navigation. In addition, when a trip occurs during operation, Trip mode will be displayed. The trip information will also be saved in the trip mode history if you release the trip using the RESET function. The two modes for mode navigation are as follows.

|  |   |
|--|---|
|  | <ul style="list-style-type: none"> <li>Displays when the inverter is powered on. This is the display of Monitor mode (MON).</li> <li>Press the [MODE] key.</li> </ul> |
|  | <ul style="list-style-type: none"> <li>You are now in Parameter mode (PAR).</li> <li>Press the [MODE] key.</li> </ul>   |

|  |  |
|--|--|
| <pre> U&amp;M →USR [N] STP 0.00Hz 00 Jump Code          9 CODE 01 Cmd Frequency      0.00 Hz 02 Cmd Torque         0.0 % </pre>  | <ul style="list-style-type: none"> <li>You are now in User &amp; Macro mode (U&amp;M).</li> <li>Press the [MODE] key.</li> </ul> |
| <pre> TRP Last-1 00 Trip Name (1)      External Trip 01 Output Freq        0.00 Hz 02 Output Current     0.0 A </pre>            | <ul style="list-style-type: none"> <li>You are now in Trip mode (TRP).</li> <li>Press the [MODE] key.</li> </ul>                 |
| <pre> CNF [N] STP 0.00Hz 00 Jump Code          40 CODE 01 Language Sel       English 03 LCD Contrast ████████████████████ </pre> | <ul style="list-style-type: none"> <li>You are now in Config mode (CNF).</li> <li>Press the [MODE] key.</li> </ul>               |
| <pre> MON T/K [N] STP 0.00Hz    0.00 Hz    0.0 A    0 V </pre>   | <ul style="list-style-type: none"> <li>You are now in Monitor mode again.</li> </ul>   |



## 6.4 Navigating Modes and Parameters

You can navigate modes by using the [Left] or [Right] keys after navigating to the Parameter Mode or User & Macro Mode via the [MODE] key.

Press the [MODE] key to navigate through modes.

Ex) Monitor -> Parameter

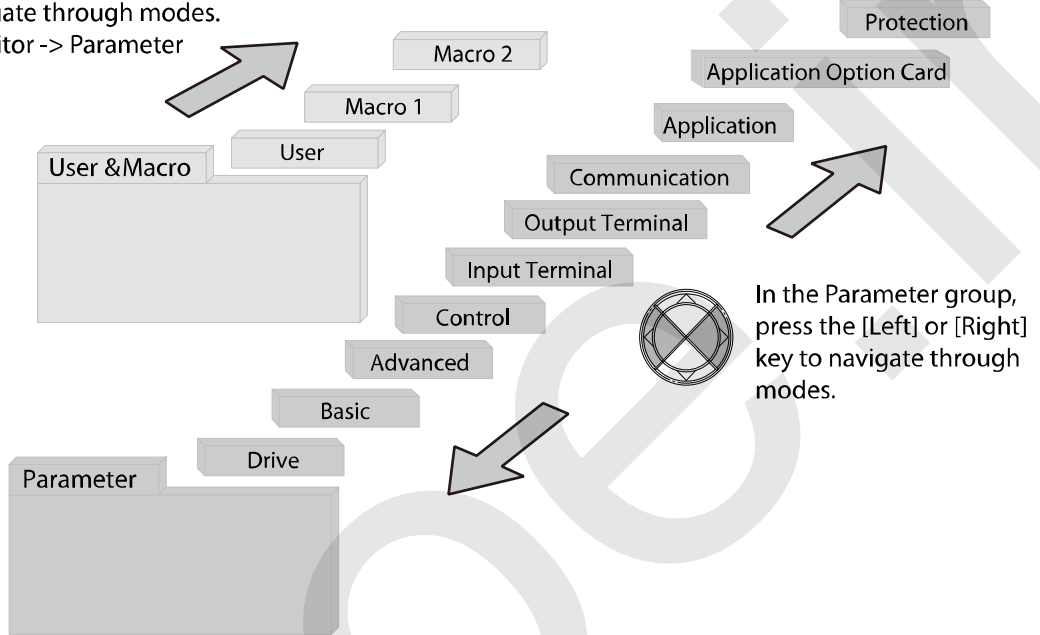

### 6.4.1 Group Navigation in Parameter mode

If you press the [Right] key in Parameter mode, the display will change as shown below. If you press the [Left] key, the display order will be reversed.

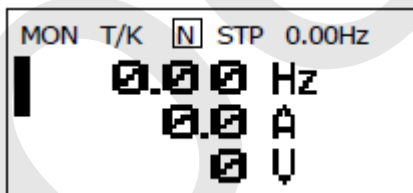

- Displays when the inverter is powered on. This is the display of Monitor mode (MON).
- Press the [MODE] key.

|   |   |
|---|---|
| <pre> PAR →DRV [N] STP 0.00Hz 00 Jump Code          9 CODE 01 Cmd Frequency      0.00 Hz 02 Cmd Torque         0.0 % </pre>     | <ul style="list-style-type: none"> <li>You are now in Parameter mode (PAR).</li> <li>The Drive Group (DRV) of Parameter mode is displayed.</li> <li>Press the [Right] key.</li> </ul> |
| <pre> PAR →BAS [N] STP 0.00Hz 00 Jump Code          20 CODE 01 Aux Ref Src        None 02 Cmd 2nd Src        Fx/Rx-1 </pre>     | <ul style="list-style-type: none"> <li>You are now in the Basic Function Group (BAS).</li> <li>Press the [Right] key.</li> </ul>  |
| <pre> PAR →ADV [N] STP 0.00Hz 00 Jump Code          24 CODE 01 Acc Pattern        Linear 02 Dec Pattern        Linear </pre>    | <ul style="list-style-type: none"> <li>You are now in the Advanced Function Group (ADV).</li> <li>Press the [Right] key 7 times.</li> </ul>   |
| <pre> PAR →PRT [N] STP 0.00Hz 00 Jump Code          40 CODE 01 Load Duty          Heavy Duty 02 Phase Loss Chk    [ ][ ] </pre> | <ul style="list-style-type: none"> <li>The group sequence will change and the Protection Function Group (PRT) will be displayed.</li> <li>Press the [Right] key.</li> </ul>           |
| <pre> PAR →DRV [N] STP 0.00Hz 00 Jump Code          9 CODE 01 Cmd Frequency      0.00 Hz 02 Cmd Torque         0.0 % </pre>     | <ul style="list-style-type: none"> <li>You are now in the Drive group (DRV) of the Parameter group again.</li> </ul>  |

## 6.4.2 Group Shift in User & Macro Mode

To navigate to User & Macro Mode, the user code should be registered or the macro function should be selected. For more details on how to register the user code and macro group, refer to [11.12 Parameter Group for Transmission of Macro Group and User Group at U&M Mode](#) on page 344. If the user code is registered and the macro function is selected, you can navigate to the group as shown below.

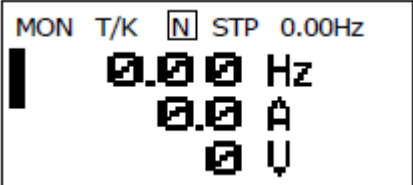
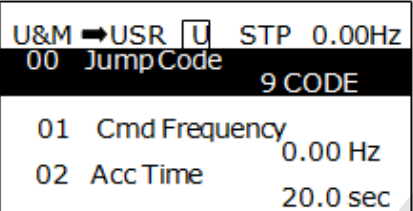
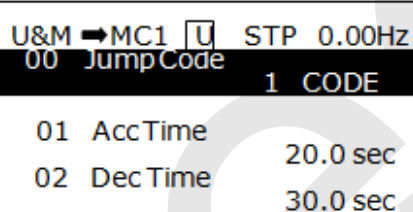
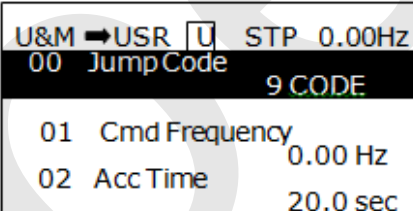
|   |   |
|---|---|
|  <p>MON T/K [N] STP 0.00Hz<br/>         0.00 Hz<br/>         0.0 A<br/>         0 V</p>  | <ul style="list-style-type: none"> <li>• Displays when the inverter is powered on. This is the display of Monitor mode (MON).</li> <li>• Press the [MODE] key twice.</li> </ul>         |
|  <p>U&amp;M -&gt;USR [U] STP 0.00Hz<br/>         00 JumpCode<br/>         9 CODE<br/>         01 Cmd Frequency 0.00 Hz<br/>         02 Acc Time 20.0 sec</p>   | <ul style="list-style-type: none"> <li>• You are now in the User &amp; Macro mode (U&amp;M).</li> <li>• The User Group (USR) is displayed.</li> <li>• Press the [Right] key.</li> </ul> |
|  <p>U&amp;M -&gt;MC1 [U] STP 0.00Hz<br/>         00 JumpCode<br/>         1 CODE<br/>         01 AccTime 20.0 sec<br/>         02 Dec Time 30.0 sec</p>      | <ul style="list-style-type: none"> <li>• You are now in the Macro group (MC1).</li> <li>• Press the [Right] key.</li> </ul>   |
|  <p>U&amp;M -&gt;USR [U] STP 0.00Hz<br/>         00 JumpCode<br/>         9 CODE<br/>         01 Cmd Frequency 0.00 Hz<br/>         02 Acc Time 20.0 sec</p> | <ul style="list-style-type: none"> <li>• You are now in the User Group (USR) again.</li> </ul>  |

## 6.5 Navigating through Codes (Function Items)

### 6.5.1 Code Navigation in Monitor Mode

To display the frequency, output current, and output voltage, press the [Up] or [Down] keys to scroll through the items.

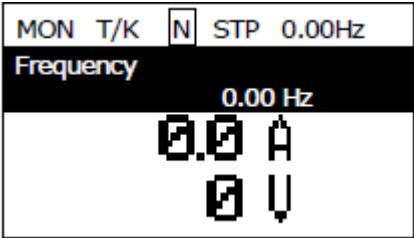
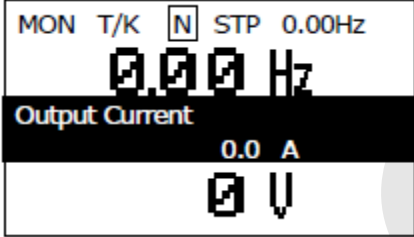
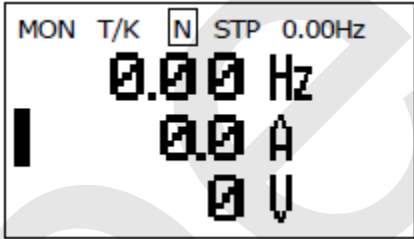
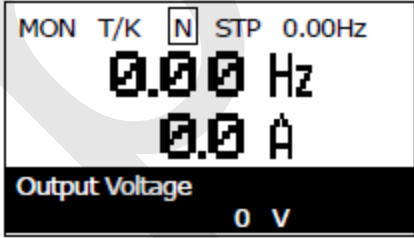
|   |   |
|---|---|
|  <p>MON T/K [N] STP 0.00Hz<br/>Frequency<br/>0.00 Hz<br/>0.0 A<br/>0 V</p>         | <ul style="list-style-type: none"> <li>• Displays when the inverter is powered on. This display is in Monitor mode.</li> <li>• The cursor is located at the frequency item.</li> <li>• Press the [Down] key.</li> </ul> |
|  <p>MON T/K [N] STP 0.00Hz<br/>0.000 Hz<br/>Output Current<br/>0.0 A<br/>0 V</p>  | <ul style="list-style-type: none"> <li>• The second display item displays the output current.</li> <li>• Do not press any key for approximately 2 seconds after navigation.</li> </ul>                                  |
|  <p>MON T/K [N] STP 0.00Hz<br/>0.000 Hz<br/>0.0 A<br/>0 V</p>                    | <ul style="list-style-type: none"> <li>• The output current text has disappeared and the cursor has moved to the second display item.</li> <li>• Press the [Down] key.</li> </ul>                                       |
|  <p>MON T/K [N] STP 0.00Hz<br/>0.000 Hz<br/>0.0 A<br/>Output Voltage<br/>0 V</p> | <ul style="list-style-type: none"> <li>• The third display item displays the output voltage.</li> <li>• Do not press any key for approximately 2 seconds after navigation.</li> </ul>                                   |

|  |  |
|--|--|
|  | <ul style="list-style-type: none"> <li>• The output voltage text has disappeared and the cursor has moved to the third display item.</li> <li>• Press the [Up] key twice.</li> </ul> |
|  | <ul style="list-style-type: none"> <li>• The first item displays the frequency.</li> </ul>   |
|  | <ul style="list-style-type: none"> <li>• The frequency text has disappeared and the cursor has moved to the first display item.</li> </ul>   |

## 6.5.2 Code Navigation (function items) in Other Modes and Groups

Using the [Up] and [Down] keys: The following example demonstrates how to navigate through the codes in the Drive (DRV) group and the Basic [BAS] group of Parameter mode. Code navigation in other modes is the same as follows.

|  |   |
|--|---|
|  | <ul style="list-style-type: none"> <li>• Displays when the inverter is powered on. This display is in Monitor mode.</li> <li>• Press the [Down] key.</li> </ul> |
|--|---|

|  |  |
|--|--|
| <pre> PAR →DRV [N] STP 0.00Hz 00 Jump Code          1 CODE 01 Cmd Frequency     0.00 Hz 02 Acc Time          20.0 sec </pre> | <ul style="list-style-type: none"> <li>Displays the Drive (DRV) group of Parameter mode. If the DRV group is not displayed, press the [MODE] key until the DRV group appears, or press the [ESC] key.</li> </ul> |
| <pre> PAR →DRV [N] STP 0.00Hz 00 Jump Code          9 CODE 01 Cmd Frequency     0.00 Hz 02 Acc Time          20.0 sec </pre> | <ul style="list-style-type: none"> <li>If you press the [Down] key, you will navigate to code No. 01 in the DRV group of Parameter mode.</li> <li>Press the [Right] key.</li> </ul>                              |
| <pre> PAR →BAS [N] STP 0.00Hz 00 Jump Code          20 CODE 01 Aux Ref Src       None 04 Cmd 2nd Src       Fx/Rx-1 </pre>    | <ul style="list-style-type: none"> <li>You have moved to the Basic (BAS) group of Parameter mode.</li> <li>You can navigate through the codes using the [Up] or [Down] keys.</li> </ul>                          |

### 6.5.3 Code Navigation Using Jump Code

In the Parameter mode and User/Macro mode groups, you can use the Jump Code Entry item to move to a desired code. It is quicker to move to a large code number using the Jump Code Entry item rather than the [Up] and [Down] keys. The following example demonstrates how to move to code No. 09 of the Drive (DRV) group.

|  |  |
|--|--|
| <pre> PAR →DRV [N] STP 0.00Hz 00 Jump Code          9 CODE 01 Cmd Frequency     0.00 Hz 02 Acc Time          20.0 sec </pre> | <ul style="list-style-type: none"> <li>Ensure that code No. 00 is displayed in the initial display of the Drive (DRV) group of Parameter mode.</li> <li>Press the [PROG/ENT] key.</li> </ul> |
|--|--|

|  |  |
|--|--|
| <pre> PAR →DRV [N] STP 0.00Hz 00 Jump Code          9 CODE 01 Cmd Frequency      0.00 Hz 02 Acc Time           20.0 sec                     </pre> | <ul style="list-style-type: none"> <li>The cursor flashes and you can enter the code number.</li> </ul>            |
| <pre> PAR →DRV [N] STP 0.00Hz 00 Jump Code          9 CODE           1~99 CODE D:9          C:9                     </pre>                         | <ul style="list-style-type: none"> <li>Press the [Up] key to enter 9 and then press the [PROG/ENT] key.</li> </ul> |
| <pre> PAR →DRV [N] STP 0.00Hz 09 Control Mode      V/F 10 Torque Control    No 11 JOG Frequency     10.00 Hz                     </pre>            | <ul style="list-style-type: none"> <li>You have moved to code No. 09 of the DRV group.</li> </ul>                  |
| <pre> PAR →DRV [N] STP 0.00Hz 00 Jump Code          9 CODE 01 Cmd Frequency      0.00 Hz 02 Acc Time           20.0 sec                     </pre> | <ul style="list-style-type: none"> <li>Press the [ESC] key to move to code No. 00 of the DRV group.</li> </ul>     |

## 6.6 Setting Parameters

### 6.6.1 Parameter Settings in Monitor Mode

You can set some parameters, such as the frequency, in Monitor mode. The following example demonstrates how to set the frequency.

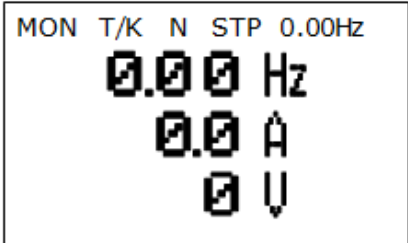
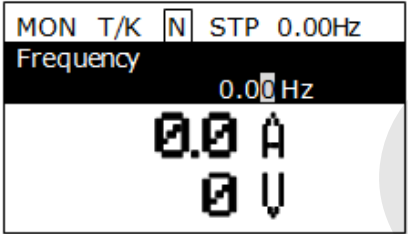
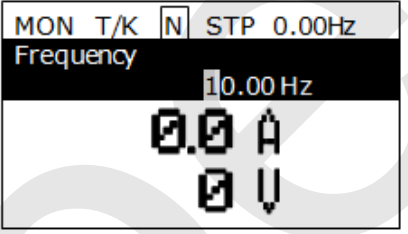
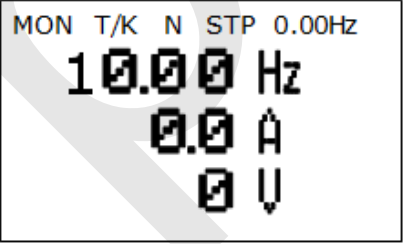
|   |  |
|---|--|
|    | <ul style="list-style-type: none"> <li>• Ensure that the cursor is at the frequency item. Also, ensure that the frequency can be set to 09 in the Drive (DRV) group using the keypad.</li> <li>• Press the [PROG/ENT] key.</li> </ul>  |
|   | <ul style="list-style-type: none"> <li>• Detailed information of the item is displayed and the cursor flashes.</li> <li>• Press the [Left] or [Right] keys to move the cursor to the desired location to set the frequency.</li> </ul> |
|  | <ul style="list-style-type: none"> <li>• Press the [Up] key to set the frequency to 10 Hz.</li> <li>• Press the [PROG/ENT] key.</li> </ul>   |
|  | <ul style="list-style-type: none"> <li>• The frequency reference is set to 10 Hz.</li> </ul>   |



## 6.6.2 Parameter Settings in Other Modes and Groups

The following example demonstrates how to change the frequency of the Drive (DRV) group in Parameter mode. The frequency in the other modes or groups can be set as follows.

|  |  |
|--|--|
| <pre> PAR →DRV [N] STP 0.00Hz 00 JumpCode          9 CODE 01 Cmd Frequency    0.00 Hz 02 Cmd Torque      0.0 %                     </pre>  | <ul style="list-style-type: none"> <li>This is the initial display in Parameter mode.</li> <li>Press the [Down] key.</li> </ul>  |
| <pre> PAR →DRV [N] STP 0.00Hz 00 JumpCode          9 CODE 01 Cmd Frequency    0.00 Hz 02 Cmd Torque      0.0 %                     </pre>  | <ul style="list-style-type: none"> <li>You have moved to the 01 frequency setting code.</li> <li>Press the [PROG/ENT] key.</li> </ul>  |
| <pre> PAR →DRV [N] STP 0.00Hz 01 Cmd Frequency 0.00 Hz 0.50 ~ 60.00 Hz D:0.00 C:0.00                     </pre>                            | <ul style="list-style-type: none"> <li>The cursor flashes and you can enter the desired frequency.</li> <li>If the frequency reference is set to 10 Hz, press the [Left] or [Right] keys to move the cursor to the desired place.</li> </ul> |
| <pre> PAR →DRV [N] STP 0.00Hz 01 Cmd Frequency 10.00 Hz 0.50 ~ 60.00 Hz D:0.00 C:0.00                     </pre>                           | <ul style="list-style-type: none"> <li>Press the [Up] key to enter 10 Hz and then press the [PROG/ENT] key.</li> </ul>   |
| <pre> PAR →DRV [N] STP 0.00Hz 00 JumpCode          9 CODE 01 Cmd Frequency    10.00 Hz 02 Cmd Torque      0.0 %                     </pre> | <ul style="list-style-type: none"> <li>The frequency reference is set to 10 Hz.</li> </ul>   |

## 6.7 Monitoring Operating Status

### 6.7.1 Using Monitor Mode

Three items can be displayed in Monitor mode at a time. Also, some items, such as the frequency item, can be edited. You can select the displayed items in Configuration (CNF) mode.

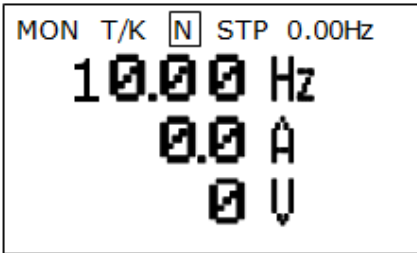
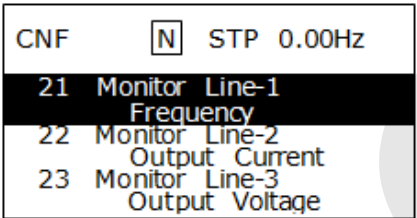
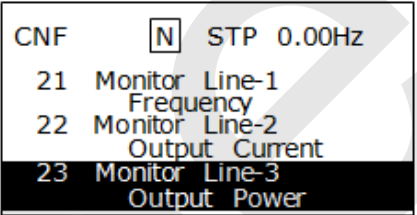
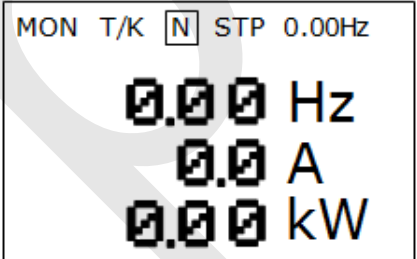
|  |   |
|--|---|
|  <p>MON T/K [N] STP 0.00Hz<br/>10.00 Hz<br/>0.0 A<br/>0 V</p>   | <ul style="list-style-type: none"> <li>This is the initial display in Monitor mode.</li> <li>The frequency, current, and voltage are set as the default monitor items.</li> <li>The frequency reference is displayed when the inverter operation has stopped, and the operating frequency is displayed when the inverter is operating.</li> </ul> |
|  <p>CNF [N] STP 0.00Hz<br/>21 Monitor Line-1<br/>Frequency<br/>22 Monitor Line-2<br/>Output Current<br/>23 Monitor Line-3<br/>Output Voltage</p> | <ul style="list-style-type: none"> <li>You can set the items to display in Monitor mode in sequence from 21 to 23 in Configuration (CNF) mode.</li> <li>Press the [Down] key to move to code No. 23</li> </ul>  |
|  <p>CNF [N] STP 0.00Hz<br/>21 Monitor Line-1<br/>Frequency<br/>22 Monitor Line-2<br/>Output Current<br/>23 Monitor Line-3<br/>Output Power</p>  | <ul style="list-style-type: none"> <li>Change the code No. 23 item in Monitor mode to the output power.</li> </ul>  |
|  <p>MON T/K [N] STP 0.00Hz<br/>0.00 Hz<br/>0.0 A<br/>0.00 kW</p>  | <ul style="list-style-type: none"> <li>Ensure that the third displayed item in Monitor mode is changed to the output power.</li> </ul>  |

### 6.7.2 Monitoring Items

| Mode | Code | Function Display | Setting Range |                 | Initial Value     |
|------|------|------------------|---------------|-----------------|-------------------|
| CNF  | 20   | Anytime Para     | 0             | Frequency       | 0: Frequency      |
|      | 21   | Monitor Line-1   | 1             | Speed           | 0: Frequency      |
|      | 22   | Monitor Line-2   | 2             | Output Current  | 2: Output Current |
|      | 23   | Monitor Line-3   | 3             | Output Voltage  | 3: Output Voltage |
|      |      |                  | 4             | Output Power    |                   |
|      |      |                  | 5             | WHour Counter   |                   |
|      |      |                  | 6             | DCLink Voltage  |                   |
|      |      |                  | 7             | DI Status       |                   |
|      |      |                  | 8             | DO Status       |                   |
|      |      |                  | 9             | V1 Monitor [V]  |                   |
|      |      |                  | 10            | V1 Monitor [%]  |                   |
|      |      |                  | 11            | I1 Monitor [mA] |                   |
|      |      |                  | 12            | I1 Monitor [%]  |                   |
|      |      |                  | 13            | V2 Monitor [V]  |                   |
|      |      |                  | 14            | V2 Monitor [%]  |                   |
|      |      |                  | 15            | I2 Monitor [mA] |                   |
|      |      |                  | 16            | I2 Monitor [%]  |                   |
|      |      |                  | 17            | PID Output      |                   |
|      |      |                  | 18            | PID Ref Value   |                   |
|      |      |                  | 19            | PID Fdb Value   |                   |
|      |      |                  | 20            | Torque          |                   |
|      |      |                  | 21            | Torque Limit    |                   |
|      |      |                  | 22            | Trq Bias Ref    |                   |
|      |      |                  | 23            | Speed Limit     |                   |
|      |      |                  | 24            | Load Speed      |                   |
| 25   |      |                  | Temperature   |                 |                   |

### 6.7.3 Using the Status Display

The items displayed on the right-top of the display are shown in other modes, including Monitor mode. If you register a desired variable in the display, you can monitor it at any time regardless of the mode navigation or change.

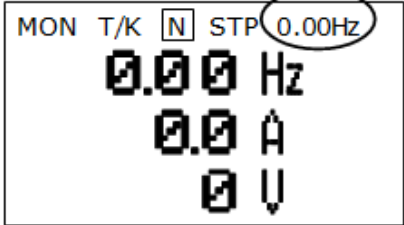
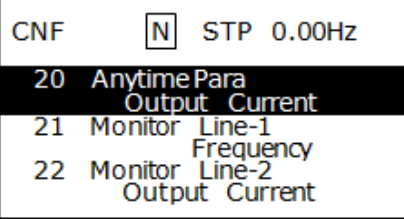
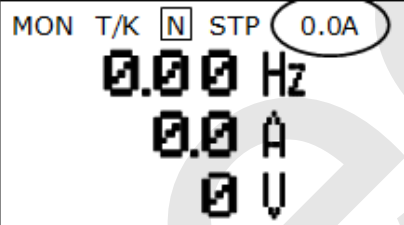
|   |   |
|---|---|
|  <p>MON T/K [N] STP 0.00Hz<br/>0.00 Hz<br/>0.0 A<br/>0 V</p>   | <ul style="list-style-type: none"> <li>• This is the initial display of Monitor mode.</li> <li>• When the inverter settings are set to the factory default, the status item displays the frequency.</li> </ul>  |
|  <p>CNF [N] STP 0.00Hz<br/>20 Anytime Para<br/>Output Current<br/>21 Monitor Line-1<br/>Frequency<br/>22 Monitor Line-2<br/>Output Current</p> | <ul style="list-style-type: none"> <li>• Select the item to display in the status display in code 20 of Configuration (CNF) mode.</li> <li>• Press the [PROG/ENT] key to change the item to the output current.</li> <li>• The unit at the top of the display is changed from hertz (frequency) to amps (current).</li> </ul> |
|  <p>MON T/K [N] STP 0.0A<br/>0.00 Hz<br/>0.0 A<br/>0 V</p>   | <ul style="list-style-type: none"> <li>• Ensure that the unit in the status display is changed to amps (current) in Monitor mode.</li> </ul>  |

## 6.8 Monitoring Faults

### 6.8.1 Faults during Inverter Operation

|   |  |
|---|--|
| <pre> TRP current <b>Over Voltage (01)</b> 01 Output Freq       48.30 Hz 02 Output Current       33.3 A                     </pre>    | <ul style="list-style-type: none"> <li>If a fault trip occurs during inverter operation, the inverter enters Trip mode automatically and displays the type of fault trip that has occurred.</li> </ul>   |
| <pre> TRP Last-1 01 Output Freq       48.30 Hz 02 Output Current       33.3 A 03 Inverter State       Stop                     </pre> | <ul style="list-style-type: none"> <li>Press the [Down] key to view the information on the inverter at the time of the fault, including the output frequency, current, and operating status.</li> </ul>  |
| <pre> MON T/K <b>N</b> STP 0.0A  0.00 Hz  0.0 A  0 V                     </pre>   | <ul style="list-style-type: none"> <li>When the inverter is reset and the fault trip is released, the keypad display returns to the screen that was displayed before the fault trip occurred.</li> </ul> |

## 6.8.2 Multiple Faults at a Time during Inverter Operation

|  |  |
|--|--|
| <pre>TRP current <b>Over Voltage (02)</b> 01 Output Freq       48.30 Hz 02 Output Current       33.3 A</pre> | <ul style="list-style-type: none"> <li>• If multiple fault trips occur at the same time, the number of fault trips that occurred is displayed next to the fault trip type.</li> <li>• Press the [PROG/ENT] key.</li> </ul> |
| <pre>TRP current <b>00 Trip Name ( 2)</b> 0 Over Voltage 1 Externa Trip</pre>                                | <ul style="list-style-type: none"> <li>• The types of all the fault trips are displayed.</li> <li>• Press the [PROG/ENT] key.</li> </ul>   |
| <pre>TRP current <b>Over Voltage (02)</b> 01 Output Freq       48.30 Hz 02 Output Current       33.3 A</pre> | <ul style="list-style-type: none"> <li>• The display mode that was shown before you checked the fault information is displayed.</li> </ul>   |

## 6.8.3 Saving and Monitoring the Fault Trip History

Previous fault trips can be saved in Trip mode. You can save up to 5 previous fault trips. Fault trips caused by resetting the inverter, as well as low voltage faults caused by the inverter being switched off, are also saved.

If there are more than 5 fault trips, the oldest 5 fault trips are automatically deleted.

|  |  |
|--|--|
| <p>TRP current</p> <p><b>Over Voltage (02)</b></p> <p>01 Output Freq<br/>48.30 Hz</p> <p>02 Output Current<br/>33.3 A</p>                            | <ul style="list-style-type: none"> <li>If a fault trip occurs during inverter operation, the inverter enters Trip mode and displays the type of fault trip that has occurred.</li> </ul>   |
| <p>MON T/K <span style="border: 1px solid black; padding: 0 2px;">N</span> STP 0.0A</p> <p>0.00 Hz</p> <p>0.0 A</p> <p>0 V</p>                       | <ul style="list-style-type: none"> <li>If you press the [STOP/RESET] key or an input is entered on the terminal, the fault trip is automatically saved and the display status that was displayed before the fault trip occurred is displayed.</li> <li>Press the [MODE] key to move to Trip mode.</li> </ul> |
| <p>TRP current</p> <p><b>00 Trip Name (2)</b></p> <p><b>Over Voltage</b></p> <p>01 Output Freq<br/>48.30 Hz</p> <p>02 Output Current<br/>33.3 A</p>  | <ul style="list-style-type: none"> <li>The most recent fault trip is saved in the Last-1 code.</li> <li>Press the [Right] key.</li> </ul>  |
| <p>TRP current</p> <p><b>00 Trip Name (1)</b></p> <p><b>External Trip</b></p> <p>01 Output Freq<br/>48.30 Hz</p> <p>02 Output Current<br/>33.3 A</p> | <ul style="list-style-type: none"> <li>The previous fault trips are saved in the Last-2 code.</li> <li>If another fault trip occurs, the previous fault trips saved in the Last-2 code move to the Last-3 code.</li> </ul>   |

## 6.9 Initializing Parameters

You can initialize the changed parameters. In addition to initializing the entire parameter, you can also select the individual parameter mode to be initialized.

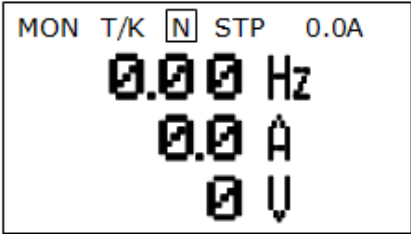
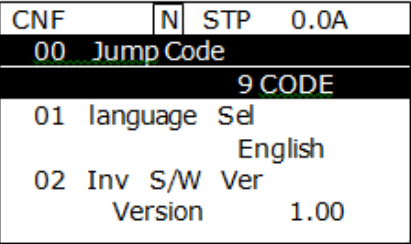
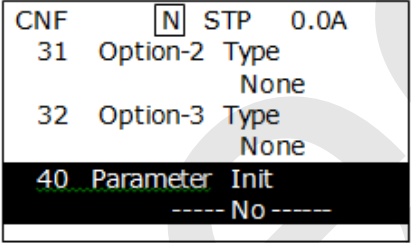
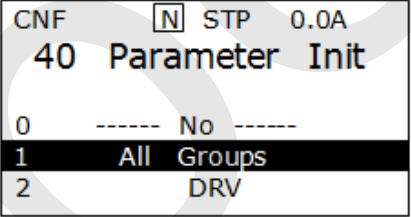
|   |  |
|---|--|
|    | <ul style="list-style-type: none"> <li>• Monitor mode is displayed.</li> </ul>   |
|    | <ul style="list-style-type: none"> <li>• Press the [MODE] key to move to Configuration (CNF) mode.</li> </ul>                                  |
|  | <ul style="list-style-type: none"> <li>• Press the [Down] key to move to code No. 40.</li> <li>• Press the [PROG/ENT] key.</li> </ul>          |
|  | <ul style="list-style-type: none"> <li>• Of the parameter items to initialize, select All Groups and then press the [PROG/ENT] key.</li> </ul> |



```
CNF      [N] STP  0.0A
31  Option-2 Type
           None
32  Option-3 Type
           None
40  Parameter Init
      ----- No -----
```

- The Parameter Initialization option is displayed again when the initialization is complete.

## 7 Basic Functions

### 7.1 Setting Frequency References

The iS7 inverter provides several methods to set up and modify a frequency reference for an operation. The keypad, analog inputs [for example voltage (V1) and current (I1) signals], or RS-485 (digital signals from higher-level controllers, such as PCs or PLCs) can be used.

| Group | Code | Name                       | LCD Display  | Parameter Setting |           | Setting Range | Unit |
|-------|------|----------------------------|--------------|-------------------|-----------|---------------|------|
| DRV   | 07   | Frequency reference source | Freq Ref Src | 0                 | KeyPad-1  | 0-9           | -    |
|       |      |                            |              | 1                 | KeyPad-2  |               |      |
|       |      |                            |              | 2                 | V1        |               |      |
|       |      |                            |              | 3                 | I1        |               |      |
|       |      |                            |              | 4                 | V2        |               |      |
|       |      |                            |              | 5                 | I2        |               |      |
|       |      |                            |              | 6                 | Int 485   |               |      |
|       |      |                            |              | 7                 | Encoder   |               |      |
|       |      |                            |              | 8                 | Field Bus |               |      |
|       |      |                            |              | 9                 | Pulse     |               |      |

### 7.1.1 Keypad as the Source (Keypad-1 setting)

You can modify the frequency reference using the keypad and apply changes by pressing the [ENT/PROG] key. To use the keypad as a frequency reference input source, go to DRV-07 (Frequency reference source) and change the parameter value to “0 (Keypad-1)”. Input the frequency reference for an operation at DRV-01 (Frequency reference).

| Group | Code | Name                       | LCD Display   | Parameter Setting |          | Setting Range        | Unit |
|-------|------|----------------------------|---------------|-------------------|----------|----------------------|------|
| DRV   | 01   | Frequency reference        | Cmd Frequency | 0.00              |          | 0.00–max. frequency* | Hz   |
|       | 07   | Frequency reference source | Freq Ref Src  | 0                 | Keypad-1 | 0–9                  | -    |

\* You cannot set a frequency reference that exceeds the max. frequency, as configured with DRV-20.

### 7.1.2 Keypad as the Source (Keypad-2 setting)

You can use the [UP] and [DOWN] cursor keys to modify a frequency reference. To use this as a second option, set the keypad as the source of the frequency reference by going to DRV-07 (Frequency reference source) and changing the parameter value to “1 (Keypad-2)”. This allows frequency reference values to be increased or decreased by pressing the [UP] and [DOWN] cursor keys.

| Group | Code | Name                       | LCD Display   | Parameter Setting |          | Setting Range         | Unit |
|-------|------|----------------------------|---------------|-------------------|----------|-----------------------|------|
| DRV   | 01   | Frequency reference        | Cmd Frequency | 0.00              |          | 0.00–max. frequency * | Hz   |
|       | 07   | Frequency reference source | Freq Ref Src  | 1                 | Keypad-2 | 0–9                   | -    |

\* You cannot set a frequency reference that exceeds the max. frequency, as configured with DRV-20.

### 7.1.3 V1 Terminal as the Source

You can set and modify a frequency reference by setting voltage inputs when using the V1 terminal. Use voltage inputs ranging from 0–10 V (unipolar) for forward-only operations. Use voltage inputs ranging from -10 to +10 V (bipolar) for both directions, with negative voltage inputs used for reverse operations.

### 7.1.3.1 Setting a Frequency Reference for 0–10 V Input

Set IN-06 (V1 Polarity) to “0 (unipolar)”. Use a voltage output from an external source or use the voltage output from the VR terminal to provide inputs to V1. Refer to the diagrams below for the wiring required for each application.



[External source application] [Internal source (VR) application]

| Group | Code | Name                              | LCD Display   | Parameter Setting |          | Setting Range       | Unit |
|-------|------|-----------------------------------|---------------|-------------------|----------|---------------------|------|
| DRV   | 07   | Frequency reference source        | Freq Ref Src  | 2                 | V1       | 0–9                 | -    |
| IN    | 01   | Frequency at maximum analog input | Freq at 100%  | Maximum frequency |          | 0.00–max. frequency | Hz   |
|       | 05   | V1 input monitor                  | V1 Monitor[V] | 0.00              |          | 0.00–10.00          | V    |
|       | 06   | V1 polarity options               | V1 Polarity   | 0                 | Unipolar | 0–1                 | -    |
|       | 07   | V1 input filter time constant     | V1 Filter     | 10                |          | 0–10000             | ms   |
|       | 08   | V1 minimum input voltage          | V1 volt x1    | 0.00              |          | 0.00–10.00          | V    |
|       | 09   | V1 output at minimum voltage (%)  | V1 Perc y1    | 0.00              |          | 0.00–100.00         | %    |
|       | 10   | V1 maximum input voltage          | V1 Volt x2    | 10.00             |          | 0.00–10.00          | V    |
|       | 11   | V1 output at maximum voltage (%)  | V1 Perc y2    | 100.00            |          | 0–100               | %    |
|       | 16   | Rotation direction options        | V1 Inverting  | 0                 | No       | 0–1                 | -    |
|       | 17   | V1 quantizing level               | V1 Quantizing | 0.04              |          | 0.00*, 0.04–10.00   | %    |

\* Quantizing is disabled if “0” is selected.

0–10 V Input Voltage Setting Details

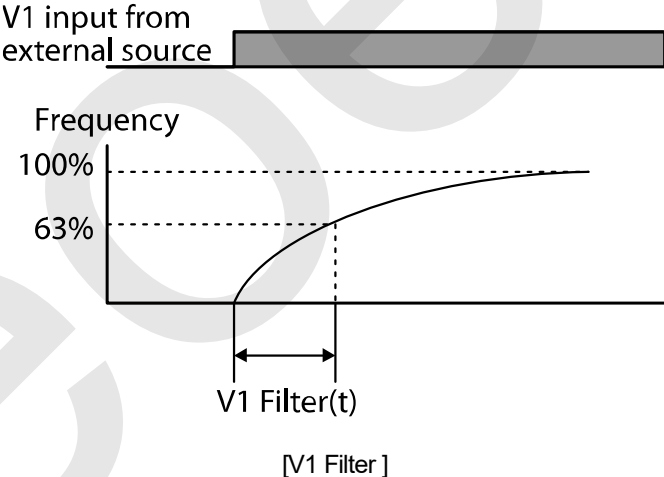
| Code                                  | Description   |
|---------------------------------------|---|
| IN-01 Freq at 100%                    | <p>Configures the frequency reference at the maximum input voltage when a potentiometer is connected to the control terminal block. A frequency set with code IN-01 becomes the maximum frequency only if the value set in code IN-11 (or IN-15) is 100%.</p> <ul style="list-style-type: none"> <li>Set code IN-01 to 40.00 and use default values for codes IN-02–IN-16. The motor will run at 40.00 Hz when a 10 V input is provided at V1.</li> <li>Set code IN-11 to 50.00 and use default values for codes IN-01–IN-16. The motor will run at 30.00 Hz (50% of the default maximum frequency–60 Hz) when a 10 V input is provided at V1.</li> </ul> |
| IN-05 V1 Monitor[V]                   | <p>Configures the inverter to monitor the input voltage at V1.</p>  |
| IN-07 V1 Filter                       | <p>The V1 filter may be used when there are large variations between reference frequencies. Variations can be mitigated by increasing the time constant, but this requires an increased response time. The value t (time) indicates the time required for the frequency to reach 63% of the reference, when external input voltages are provided in multiple steps.</p> <div style="text-align: center;">  <p>V1 input from external source</p> <p>Frequency</p> <p>100%</p> <p>63%</p> <p>V1 Filter(t)</p> <p>[V1 Filter]</p> </div>                                  |
| IN-08 V1 volt x1–<br>IN-11 V1 Perc y2 | <p>These parameters are used to configure the gradient level and offset values of the output frequency, based on the input voltage.</p>   |

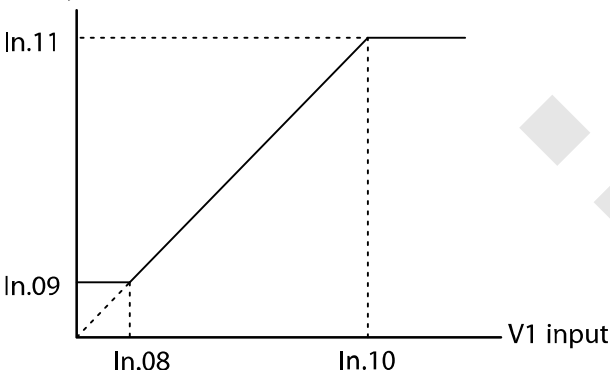
| Code                | Description   |
|---------------------|---|
|                     | <p>Frequency reference</p>    |
| IN-16 V1 Inverting  | <p>Inverts the direction of rotation. Set this code to “1 (Yes)” if you need the motor to run in the opposite direction from the current rotation.</p>  |
| IN-17 V1 Quantizing | <p>Quantizing may be used when the noise level is high in the analog input (V1 terminal) signal. Quantizing is useful when you are operating a noise-sensitive system, because it suppresses any signal noise. However, quantizing will diminish system sensitivity (resultant power of the output frequency will decrease based on the analog input). You can also turn on the low-pass filter using code IN-07 to reduce the noise, but increasing the value will reduce responsiveness and may cause pulsations (ripples) in the output frequency.</p> <p>Parameter values for quantizing refer to a percentage based on the maximum input. Therefore, if the value is set to 1% of the maximum analog input (60 Hz), the output frequency will increase or decrease by 0.6 Hz for every 0.1 V change in voltage.</p> <p>When the analog input is increased, an increase in the input equal to 75% of the set value will change the output frequency, and then the frequency will increase according to the set value. Likewise, when the analog input decreases, a decrease in the input equal to 75% of the set value will make an initial change to the output frequency.</p> <p>As a result, the output frequency will be different at acceleration and deceleration, mitigating the effect of analog input changes over the output frequency (ripples).</p> |

| Code             | Description  |                  |                       |       |     |       |     |     |     |       |     |     |     |       |      |       |      |    |       |
|------------------|--|------------------|-----------------------|-------|-----|-------|-----|-----|-----|-------|-----|-----|-----|-------|------|-------|------|----|-------|
|                  | <p>Output frequency (Hz)</p> <p>Analog input (V)</p> <p>[V1 Quantizing]</p> <table border="1"> <caption>Quantization Data Points</caption> <thead> <tr> <th>Analog Input (V)</th> <th>Output Frequency (Hz)</th> </tr> </thead> <tbody> <tr> <td>0.025</td> <td>0.6</td> </tr> <tr> <td>0.075</td> <td>0.6</td> </tr> <tr> <td>0.1</td> <td>1.2</td> </tr> <tr> <td>0.175</td> <td>1.2</td> </tr> <tr> <td>0.2</td> <td>1.2</td> </tr> <tr> <td>9.925</td> <td>59.4</td> </tr> <tr> <td>9.975</td> <td>59.4</td> </tr> <tr> <td>10</td> <td>60.00</td> </tr> </tbody> </table> | Analog Input (V) | Output Frequency (Hz) | 0.025 | 0.6 | 0.075 | 0.6 | 0.1 | 1.2 | 0.175 | 1.2 | 0.2 | 1.2 | 9.925 | 59.4 | 9.975 | 59.4 | 10 | 60.00 |
| Analog Input (V) | Output Frequency (Hz)  |                  |                       |       |     |       |     |     |     |       |     |     |     |       |      |       |      |    |       |
| 0.025            | 0.6  |                  |                       |       |     |       |     |     |     |       |     |     |     |       |      |       |      |    |       |
| 0.075            | 0.6  |                  |                       |       |     |       |     |     |     |       |     |     |     |       |      |       |      |    |       |
| 0.1              | 1.2  |                  |                       |       |     |       |     |     |     |       |     |     |     |       |      |       |      |    |       |
| 0.175            | 1.2  |                  |                       |       |     |       |     |     |     |       |     |     |     |       |      |       |      |    |       |
| 0.2              | 1.2  |                  |                       |       |     |       |     |     |     |       |     |     |     |       |      |       |      |    |       |
| 9.925            | 59.4   |                  |                       |       |     |       |     |     |     |       |     |     |     |       |      |       |      |    |       |
| 9.975            | 59.4   |                  |                       |       |     |       |     |     |     |       |     |     |     |       |      |       |      |    |       |
| 10               | 60.00  |                  |                       |       |     |       |     |     |     |       |     |     |     |       |      |       |      |    |       |

### 7.1.3.2 Setting a Frequency Reference for -10~+10 V Input

Set DRV-07 (Frequency reference source) to “2 (V1)”, and then set IN-06 (V1 Polarity) to “1 (bipolar)”. Use the output voltage from an external source to provide an input to V1.

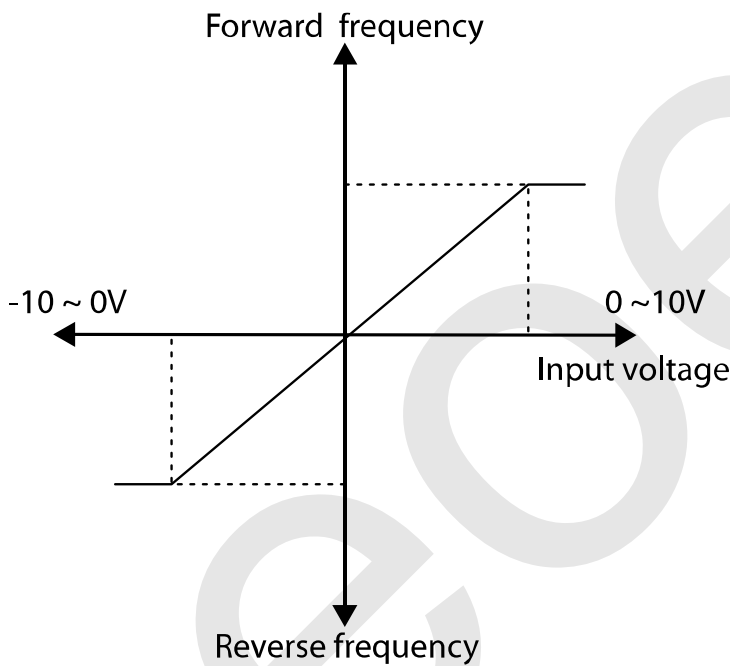
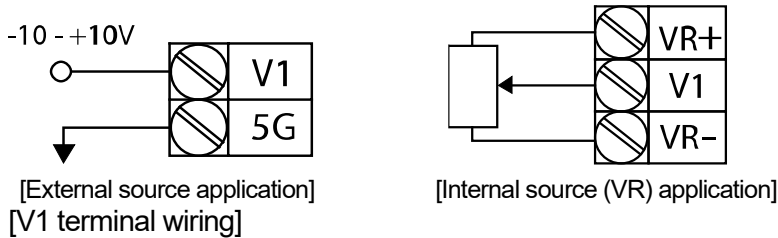

[Bipolar input voltage and output frequency]

| Group | Code | Name                              | LCD Display  | Parameter Setting | Setting Range    | Unit |
|-------|------|-----------------------------------|--------------|-------------------|------------------|------|
| DRV   | 07   | Frequency reference source        | Freq Ref Src | 2   V1            | 0-9              | -    |
| IN    | 01   | Frequency at maximum analog input | Freq at 100% | 60.00             | 0-max. frequency | Hz   |
|       | 05   | V1 input monitor                  | V1 Monitor   | 0.00              | 0.00-10.00 V     | V    |
|       | 06   | V1 polarity options               | V1 Polarity  | 1   Bipolar       | 0-1              | -    |
|       | 12   | V1 minimum input                  | V1- volt x1  | 0.00              | 0.00-10.00 V     | V    |



| Group | Code | Name                             | LCD Display | Parameter Setting | Setting Range | Unit |
|-------|------|----------------------------------|-------------|-------------------|---------------|------|
|       |      | voltage                          |             |                   |               |      |
|       | 13   | V1 output at minimum voltage (%) | V1- Perc y1 | 0.00              | -100.00–0.00% | %    |
|       | 14   | V1 maximum input voltage         | V1- Volt x2 | -10.00            | -10.00–0.00 V | V    |
|       | 15   | V1 output at maximum voltage (%) | V1- Perc y2 | -100.00           | -100.00–0.00% | %    |

**Rotational Directions for Different Voltage Inputs**

| Command / Voltage Input | Input voltage |         |
|-------------------------|---------------|---------|
|                         | 0–10 V        | -10–0 V |
| FWD                     | Forward       | Reverse |
| REV                     | Reverse       | Forward |

**10–10 V Voltage Input Setting Details**

| Code                                    | Description   |
|---|---|
| IN-12 V1- volt x1–<br>IN-15 V1- Perc y2 | <p>Sets the gradient level and offset value of the output frequency in relation to the input voltage. These codes are displayed only when IN-06 is set to “1 (bipolar)”. As an example, if the minimum input voltage (at V1) is set to “-2 (V)” with 10% output ratio, and the maximum voltage is set to “-8 (V)” with an 80% output ratio, the output frequency will vary within the range of 6–48 Hz.</p> <p>V1 input</p> |

| Code | Description   |
|------|---|
|      | For details about the 0→+10 V analog inputs, refer to the code descriptions IN-08 V1 volt x1–IN-11 V1 Perc y2 on page <a href="#">143</a> |

### 7.1.3.3 Setting a Reference Frequency using Input Current (I1)

You can set and modify a frequency reference using input current at the I1 terminal. Set DRV-07 (Frequency reference source) to “3 (I1)” and apply an input current of 0–20 mA to I1.

| Group | Code | Name                              | LCD Display   | Parameter Setting |    | Setting Range     | Unit |
|-------|------|-----------------------------------|---------------|-------------------|----|-------------------|------|
| DRV   | 07   | Frequency reference source        | Freq Ref Src  | 3                 | I1 | 0–9               | -    |
| IN    | 01   | Frequency at maximum analog input | Freq at 100%  | 60.00             |    | 0–max. frequency  | Hz   |
|       | 20   | I1 input monitor                  | I1 Monitor    | 0.00              |    | 0.00–20.00        | mA   |
|       | 22   | I1 input filter time constant     | I1 Filter     | 10                |    | 0–10000           | ms   |
|       | 23   | I1 minimum input current          | I1 Curr x1    | 4.00              |    | 0.00–20.00        | mA   |
|       | 24   | I1 output at minimum current (%)  | I1 Perc y1    | 0.00              |    | 0–100             | %    |
|       | 25   | I1 maximum input current          | I1 Curr x2    | 20.00             |    | 4.00–20.00        | mA   |
|       | 26   | I1 output at maximum current (%)  | I1 Perc y2    | 100.00            |    | 0.00–100.00       | %    |
|       | 31   | I1 rotation direction options     | I1 Inverting  | 0                 | No | 0–1               | -    |
|       | 32   | I1 quantizing level               | I1 Quantizing | 0.04              |    | 0.00*, 0.04–10.00 | %    |

\* Quantizing is disabled if “0” is selected.

## Input Current (I1) Setting Details

| Code                                  | Description   |
|---------------------------------------|---|
| IN-01 Freq at 100%                    | <p>Configures the frequency reference for operation at the maximum current (when IN-26 is set to 100%).</p> <ul style="list-style-type: none"> <li>If IN-01 is set to 40.00, and default settings are used for IN-23–26, an input current of 20 mA (max) to I1 will produce a frequency reference of 40.00 Hz.</li> <li>If IN-26 is set to 50.00, and default settings are used for IN-01 (60 Hz) and IN-23–26, an input current of 20 mA (max) to I1 will produce a frequency reference of 30.00 Hz (50% of 60 Hz).</li> </ul> |
| IN-20 I1 Monitor                      | Used to monitor the input current at I1.  |
| IN-22 I1 Filter                       | Configures the time for the operation frequency to reach 63% of the target frequency based on the input current at I1.  |
| IN-23 I1 Curr x1–<br>IN-26 I1 Perc y2 | <p>Configures the gradient level and offset value of the output frequency.</p> <p>Frequency reference</p> <p>[Gradient and offset configuration based on output frequency]</p>  |
| IN-32 I1 Quantizing                   | Same as V1 Quantizing. For more details, refer to <a href="#">7.1.3.1 Setting a Frequency Reference for 0–10 V Input</a> on page 139.   |

## 7.1.4 Setting a Frequency Reference Using an I/O Expansion Module (Terminal V2/I2)

After installing an optional I/O expansion module to the iS7 inverter, you can set and modify a frequency reference using the input voltage or current at the V2/I2 terminal.

### 7.1.4.1 Setting a Reference Frequency using Input Voltage at V2 Terminal

Set the DRV-07 (Frequency reference source) to “4 (V2)” and apply an input voltage of -10→+12 V to the V2 terminal.

| Group | Code                | Name                           | LCD Display  | Parameter Setting |                   | Setting Range | Unit |
|-------|---------------------|--------------------------------|--------------|-------------------|-------------------|---------------|------|
| DRV   | 07                  | Frequency reference source     | Freq Ref Src | 4                 | V2                | 0–9           | -    |
| IN    | 35                  | V2 input display               | V2 Monitor   | 0.00              |                   | -10.00→+10.00 | V    |
|       | 37                  | V2 input filter time constant  | V2 Filter    | 10                |                   | 0–10000       | ms   |
|       | 38                  | Minimum V2 input voltage       | V2 Volt x1   | 0.00              |                   | 0.00–10.00    | V    |
|       | 39                  | Output% at minimum V2 voltage  | V2 Perc y1   | 0.00              |                   | 0.00–100.00   | %    |
|       | 40                  | Maximum V2 input voltage       | V2 Volt x2   | 10.00             |                   | 0.00–10.00    | V    |
|       | 41                  | Output% at maximum V2 voltage  | V2 Perc y2   | 100.00            |                   | 0.00–100.00   | %    |
|       | 42                  | Minimum V2 input voltage'      | V2 -Volt x1' | 0.00              |                   | 0–10          | V    |
|       | 43                  | Output% at minimum V2 voltage' | V2 -Perc y1' | 0.00              |                   | 0–100         | %    |
|       | 44                  | Maximum V2 input voltage'      | V2 -Volt x2' | -10.00            |                   | 0–10          | V    |
|       | 45                  | Output% at maximum V2' voltage | V2 -Perc y2' | -100.00           |                   | -100–0        | %    |
|       | 46                  | Invert V2 rotational direction | V2 Inverting | No                |                   | No/Yes        | -    |
| 47    | V2 quantizing level | V2 Quantizing                  | 0.04         |                   | 0.00*, 0.04–10.00 | %             |      |

\* Quantizing is disabled if “0” is selected.

### 7.1.4.2 Setting a Reference Frequency using Input Current at I2 Terminal

Set the DRV-07 (Frequency reference source) to “5 (I2)” and apply an input voltage of 0–20 mA to the I2 terminal.

| Group | Code | Name                             | LCD Display   | Parameter Setting |    | Setting Range     | Unit |
|-------|------|----------------------------------|---------------|-------------------|----|-------------------|------|
| DRV   | 07   | Frequency reference source       | Freq Ref Src  | 5                 | I2 | 0–9               | -    |
|       | 50   | I2 input monitor                 | I2 Monitor    | 0.00              |    | 0.00–20.00        | mA   |
|       | 52   | I2 input filter time constant    | I2 Filter     | 10                |    | 0–10000           | ms   |
|       | 53   | I2 minimum input current         | I2 Curr x1    | 4.00              |    | 0.00–20.00        | mA   |
|       | 54   | I2 output at minimum current (%) | I2 Perc y1    | 0.00              |    | 0–100             | %    |
|       | 55   | I2 maximum input current         | I2 Curr x2    | 20.00             |    | 4.00–20.00        | mA   |
|       | 56   | I2 output at maximum current (%) | I2 Perc y2    | 100.00            |    | 0.00–100.00       | %    |
|       | 61   | I2 rotation direction options    | I2 Inverting  | 0                 | No | 0–1               | -    |
|       | 62   | I2 quantizing level              | I2 Quantizing | 0.04              |    | 0.00*, 0.04–10.00 | %    |

\* Quantizing is disabled if “0” is selected.

## 7.1.5 Setting a Frequency with Pulse Input (with an optional encoder module)

After installing an optional encoder module, you can set a frequency reference by setting DRV-07 (Frequency reference source) to “9 (Pulse)” and providing a pulse frequency of 0–32.00 kHz to the pulse input terminal.

| Group | Code | Name                              | LCD Display   | Parameter Setting |           | Setting Range       | Unit |
|-------|------|-----------------------------------|---------------|-------------------|-----------|---------------------|------|
| DRV   | 07   | Frequency reference source        | Freq Ref Src  | 7                 | Encoder   | 0–9                 | -    |
| IN    | 01   | Frequency at maximum analog input | Freq at 100%  | 60.00             |           | 0.00–max. frequency | Hz   |
| APO   | 01   | Encoder option mode               | Enc Opt Mode  | 2                 | Reference | 0-2                 | -    |
|       | 04   | Encoder type selection            | Enc Type Sel  | 0                 | -         | 0-2                 | -    |
|       | 05   | Encoder pulse selection           | Enc Pulse Sel | 2                 | A         | 0-2                 | -    |
|       | 06   | Encoder pulse number              | Enc Pulse Num | -                 |           | 10-5000             | -    |
|       | 09   | Pulse input display               | Pulse Monitor | -                 |           | -                   | kHz  |
|       | 10   | Encoder filter time constant      | Enc Filter    | 10                |           | 0-10000             | ms   |
|       | 93   | Minimum pulse input               | Enc Pulse x1  | 0.0               |           | 0-100               | kHz  |
|       | 94   | Minimum pulse Output%             | Enc Perc Y1   | 0.00              |           | 0-100               | %    |
|       | 95   | Maximum pulse input               | Enc Pulse x2  | 100.0             |           | 0-200               | kHz  |
|       | 96   | Maximum pulse Output%             | Enc Perc y2   | 100.00            |           | 0-100               | %    |

\* Quantizing is disabled if “0” is selected.

## Pulse Input Setting Details

| Code                                  | Description   |
|---------------------------------------|---|
| APO-01 Enc Opt Mode                   | Sets the encoder option mode. Set APO-01 to "2 (Reference)" to receive a pulse input for the frequency reference.                 |
| APO-04 Enc Type Sel                   | Sets the output type.   |
| APO-05 Enc Pulse Sel                  | Selects the encoder pulse to use.   |
| APO-06 Enc Pulse Num                  | Sets the number of pulses that is appropriate for the encoder specification.  |
| APO-09 Pulse Monitor                  | Displays the pulse frequency supplied at the encoder option module when APO-1 is set to "2 (Reference)".                          |
| APO-10 Enc Filter                     | Sets the time for the pulse input to reach 63% of its nominal frequency (when the pulse frequency is supplied in multiple steps). |
| APO-11 Enc Pulse x1-IN-96 Enc Perc y2 | <p>Configures the gradient level and offset values for the output frequency.</p> <p>Frequency reference</p>                       |



### 7.1.6 Setting a Frequency Reference via RS-485 Communication

Control the inverter with upper-level controllers, such as PCs or PLCs, via RS-485 communication. Set DRV-07 (Frequency reference source) to “6 (Int 485)” and use the RS-485 signal input terminals (S+/S-/SG) for communication. For more details, refer to *11 Communication Function* on page 334.

| Group | Code | Name   | LCD Display  | Parameter Setting |              | Setting Range | Unit |
|-------|------|--|--------------|-------------------|--------------|---------------|------|
| DRV   | 07   | Frequency reference source                   | Freq Ref Src | 6                 | Int 485      | 0–9           | -    |
| COM   | 01   | Integrated RS-485 communication inverter ID  | Int485 St ID | -                 | 1            | 1–250         | -    |
|       | 02   | Integrated communication protocol            | Int485 Proto | 0                 | ModBus RTU   | 0–2           | -    |
|       |      |  |              | 1                 | ModBus ASCII |               |      |
|       |      |  |              | 2                 | LS Inv 485   |               |      |
|       | 04   | Integrated communication speed               | Int485 BaudR | 3                 | 9600 bps     | 1200–38400    | bps  |
|       | 04   | Integrated communication frame configuration | Int485 Mode  | 0                 | D8/PN/S1     | 0–3           | -    |
|       |      |  |              | 1                 | D8/PN/S2     |               |      |
|       |      |  |              | 2                 | D8/PE/S1     |               |      |
| 3     |      |  |              | D8/PO/S1          |              |               |      |

## 7.2 Frequency Hold by Analog Input

If you set a frequency reference via the analog input at the control terminal block, you can hold the operation frequency of the inverter by assigning a multi-function input as the analog frequency hold terminal. The operation frequency will be linked to the analog input signal.

| Group | Code  | Name                       | LCD Display  | Parameter Setting |             | Setting Range | Unit |
|-------|-------|----------------------------|--|-------------------|-------------|---------------|------|
| DRV   | 07    | Frequency reference source | Freq Ref Src   | 0                 | Keypad-1    | 0-9           | -    |
|       |       |                            |  | 1                 | Keypad-2    |               |      |
|       |       |                            |  | 2                 | V1          |               |      |
|       |       |                            |  | 3                 | I1          |               |      |
|       |       |                            |  | 4                 | V2          |               |      |
|       |       |                            |  | 5                 | I2          |               |      |
|       |       |                            |  | 6                 | Int 485     |               |      |
|       |       |                            |  | 7                 | Encoder     |               |      |
|       |       |                            |  | 8                 | Field Bus   |               |      |
|       |       |                            |  | 9                 | PLC         |               |      |
| IN    | 65-75 | Px terminal configuration  | Px Define(Px: P1-P8 [optional: P9-P11]) [Optional P9-11] | 21                | Analog Hold | 65-75         | -    |

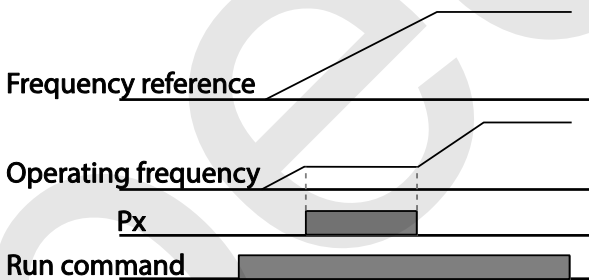

### 7.3 Changing the Displayed Units (Hz↔Rpm)

You can change the units used to display the operational speed of the inverter by setting DRV- 21 (Speed unit selection) to “0 (Hz Display)” or “1 (Rpm Display)”.

| Group | Code | Name                 | LCD Display | Parameter Setting |             | Setting Range | Unit |
|-------|------|----------------------|-------------|-------------------|-------------|---------------|------|
| DRV   | 21   | Speed unit selection | Hz/Rpm Sel  | 0                 | Hz Display  | 0–1           | -    |
|       |      |                      |             | 1                 | Rpm Display |               |      |

### 7.4 Setting Multi-Step Frequency

Multi-step operations can be carried out by assigning different speeds (or frequencies) to the Px terminals. Step 0 uses the frequency reference source set at DRV-07. Px terminal parameter values 7 (Speed-L), 8 (Speed-M), 9 (Speed-H), and 10 (Speed-X) are recognized as binary commands and work in combination with Fx or Rx run commands. The inverter operates according to the frequencies set at BAS-50–64 (multi-step frequency 1–15) and the binary command combinations.

| Group | Code  | Name                          | LCD Display  | Parameter Setting |         | Setting Range | Unit |
|-------|-------|-------------------------------|--|-------------------|---------|---------------|------|
| DRV   | 07    | Frequency reference source    | Freq Ref Src   | -                 |         | -             | -    |
| BAS   | 50–64 | Multi-step frequency 1–15     | Step Freq - x  | -                 |         | -             | Hz   |
| IN    | 65–75 | Px terminal configuration     | Px Define (Px: P1–P8 [optional: P9–P11]) [Optional P9–P11] | 7                 | Speed-L | 0–51          | -    |
|       |       |                               |  | 8                 | Speed-M |               | -    |
|       |       |                               |  | 9                 | Speed-H |               | -    |
|       |       |                               |  | 10                | Speed-X |               | -    |
|       | 89    | Multi-step command delay time | InCheck Time   | 1                 |         | 1–5000        | ms   |

**Multi-step Frequency Setting Details**

| Code | Description |
|------|-------------|
|------|-------------|

BAS Group 50–64 Configure multi-step frequency 1–15.

Choose the terminals to set up as multi-step inputs, and then set the relevant codes (IN-65–75) to 7 (Speed-L), 8 (Speed-M), 9 (Speed-H), or 10 (Speed-X). Provided that terminals P6, P7, and P8 have been set to Speed-L, Speed-M and Speed-H respectively, the following multi-step operation will be available.

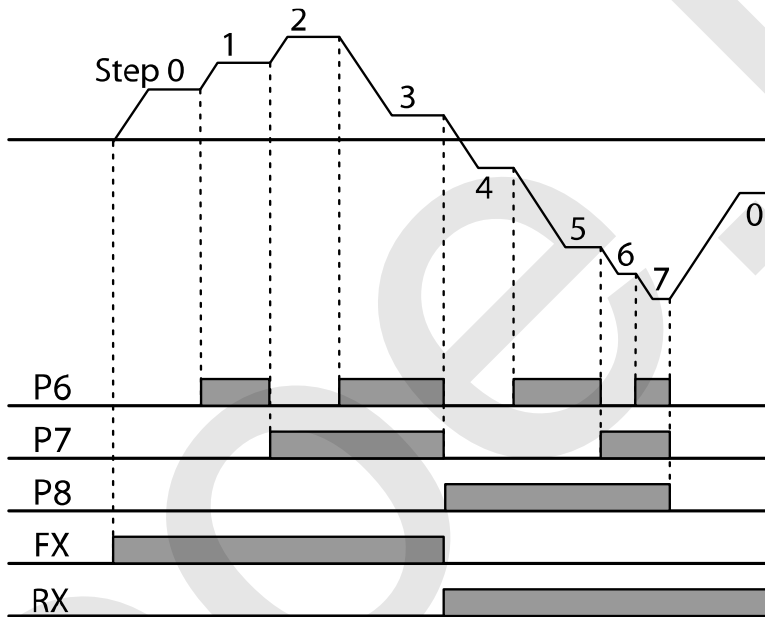

IN-65–75 Px Define

[An example of a multi-step operation]

| Speed | Fx/Rx | P8 | P7 | P6 |
|-------|-------|----|----|----|
| 0     | ✓     | -  | -  | -  |
| 1     | ✓     | -  | -  | ✓  |
| 2     | ✓     | -  | ✓  | -  |
| 3     | ✓     | -  | ✓  | ✓  |
| 4     | ✓     | ✓  | -  | -  |
| 5     | ✓     | ✓  | -  | ✓  |
| 6     | ✓     | ✓  | ✓  | -  |
| 7     | ✓     | ✓  | ✓  | ✓  |

By setting the Speed-X, you can configure up to 16 multi-step speeds, where the highest bit is Speed-X.

| Speed | Fx/Rx | P8 | P7 | P6 | P5 |
|-------|-------|----|----|----|----|
| 0     | ✓     | -  | -  | -  | -  |

| Code               | Description  |   |   |   |   |   |
|--------------------|--|---|---|---|---|---|
|                    | 1  | ✓ | - | - | - | ✓ |
|                    | 2  | ✓ | - | - | ✓ | - |
|                    | 3  | ✓ | - | - | ✓ | ✓ |
|                    | 4  | ✓ | - | ✓ | - | - |
|                    | 5  | ✓ | - | ✓ | - | ✓ |
|                    | 6  | ✓ | - | ✓ | ✓ | - |
|                    | 7  | ✓ | - | ✓ | ✓ | ✓ |
|                    | 8  | ✓ | ✓ | - | - | - |
|                    | 9  | ✓ | ✓ | - | - | ✓ |
|                    | 10   | ✓ | ✓ | - | ✓ | - |
|                    | 11   | ✓ | ✓ | - | ✓ | ✓ |
|                    | 12   | ✓ | ✓ | ✓ | - | - |
|                    | 13   | ✓ | ✓ | ✓ | - | ✓ |
|                    | 14   | ✓ | ✓ | ✓ | ✓ | - |
|                    | 15   | ✓ | ✓ | ✓ | ✓ | ✓ |
| IN-89 InCheck Time | <p>Set a time interval for the inverter to check for additional terminal block inputs after receiving an input signal.</p> <p>After IN-89 is set to 100 ms and an input signal is received at P6, the inverter will search for inputs at other terminals for 100 ms, before proceeding to accelerate or decelerate based on the configuration at P6.</p> |   |   |   |   |   |

## 7.5 Command Source Configuration

Various devices can be selected as command input devices for the iS7 inverter. Input devices available include the keypad, multi-function input terminal, RS-485 communication, and field bus adapter.

| Group | Code | Name           | LCD Display | Parameter Setting |           | Setting Range | Unit |
|-------|------|----------------|-------------|-------------------|-----------|---------------|------|
| DRV   | 06   | Command Source | Cmd Source  | 0                 | Keypad    | 0-5           | -    |
|       |      |                |             | 1                 | Fx/Rx-1   |               |      |
|       |      |                |             | 2                 | Fx/Rx-2   |               |      |
|       |      |                |             | 3                 | Int 485   |               |      |
|       |      |                |             | 4                 | Field Bus |               |      |
|       |      |                |             | 5                 | PLC       |               |      |

### 7.5.1 The Keypad as a Command Input Device

Set DRV-06 to "0 (Keypad)" to select the keypad as the command source.

Since the keypad is now the command source, forward or reverse operation starts when the [FWD] or [REV] key is pressed, and it stops when the [STOP/RESET] key is pressed.

| Group | Code | Name           | LCD Display | Parameter Setting |        | Setting Range | Unit |
|-------|------|----------------|-------------|-------------------|--------|---------------|------|
| DRV   | 06   | Command source | Cmd Source  | 0                 | KeyPad | 0-5           | -    |

## 7.5.2 The Terminal Block as a Command Input Device (Fwd/Rev run commands)

Multi-function terminals can be selected as a command input device. This is configured by setting DRV-06 (command source) to “1 (Fx/Rx-1)”. Select two terminals for the forward and reverse operations, and then set the relevant codes (2 of the 11 multi-function terminal codes, IN-65–75 for P1–P8 [optional: P9–P11]) to “1 (Fx)” and “2 (Rx)” respectively. This application enables both terminals to be turned on or off at the same time, constituting a stop command that will cause the inverter to stop operating.

| Group | Code  | Name                      | LCD Display                              | Parameter Setting |         | Setting Range | Unit |
|-------|-------|---------------------------|--|-------------------|---------|---------------|------|
| DRV   | 06    | Command source            | Cmd Source                               | 1                 | Fx/Rx-1 | 0–5           | -    |
| IN    | 65–75 | Px terminal configuration | Px Define(Px: P1– P8 [optional: P9–P11]) | 1                 | Fx      | 0–51          | -    |
|       |       |                           |  | 2                 | Rx      |               |      |
|       | 88    | Delay time setting        | Run On Delay                             | -                 | 1.00    | 0.00–100.00   | Sec  |

### Fwd/Rev Command by Multi-function Terminal – Setting Details

| Code               | Description   |
|--------------------|---|
| DRV-06 Cmd Source  | Set to “1 (Fx/Rx-1)”.   |
| IN-65–75 Px Define | Assign a terminal for forward (Fx) operation.<br>Assign a terminal for reverse (Rx) operation.  |
| IN-88 Run On Delay | Set the delay time if the inverter operation needs to be synchronized with other sequences. When the run command input (Fx/Rx) is given, the operation begins after the set time has elapsed. |

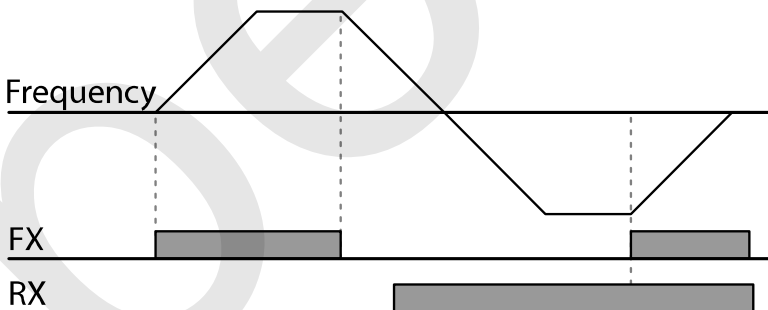

### 7.5.3 The Terminal Block as a Command Input Device (Run and Rotation Direction Commands)

Multi-function terminals can be selected as a command input device. This is configured by setting DRV-06 (command source) to “2 (Fx/Rx-2)”. Select two terminals for run and rotation direction commands, and then set the relevant codes (2 of the 11 multi-function terminal codes, IN-65–75 for P1–P11 [optional: P9–P11]) to “1 (Fx)” and “2 (Rx)” respectively. This application uses an Fx input as a run command, and an Rx input to change a motor’s rotation direction (On: Rx, Off: Fx).

| Group | Code  | Name                      | LCD Display                              | Parameter Setting |         | Setting Range | Unit |
|-------|-------|---------------------------|--|-------------------|---------|---------------|------|
| DRV   | 06    | Command source            | Cmd Source                               | 2                 | Fx/Rx-2 | 0–5           | -    |
| IN    | 65–75 | Px terminal configuration | Px Define (Px: P1–P8 [optional: P9–P11]) | 1                 | Fx      | -             | -    |
|       |       |                           |  | 2                 | Rx      |               |      |
|       | 88    | Delay time setting        | Run On Delay                             | -                 | 1.00    | 0.00–100.00   | Sec  |

#### Run Command and Fwd/Rev Change Command Using Multi-function Terminal – Setting Details

| Code               | Description   |
|--------------------|---|
| DRV-06 Cmd Source  | Set to “2 (Fx/Rx-2)”.   |
| IN-65–75 Px Define | Assign a terminal for the run command (Fx).<br>Assign a terminal for changing the rotation direction (Rx).  |
| IN-88 Run On Delay | Set the delay time if the inverter operation needs to be synchronized with other sequences. When the run command input (Fx/Rx) is given, the operation begins after the set time has elapsed. |

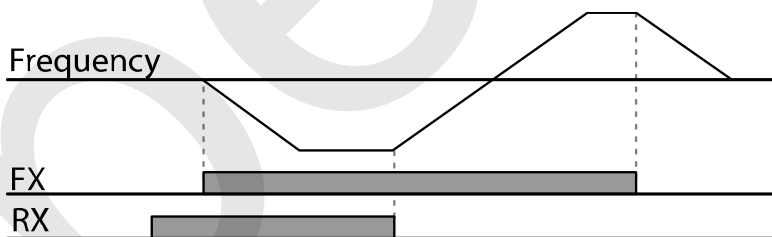



## 7.5.4 RS-485 Communication as a Command Input Device

Internal RS-485 communication can be selected as a command input device by setting DRV-06 (command source) in the Drive group to “3 (Int 485)”. This configuration uses upper level controllers, such as PCs or PLCs, to control the inverter by transmitting and receiving signals via the S+, S-, and RS-485 signal input terminals at the terminal block. For more details, refer to [11 Communication Function](#) on page 334.

| Group | Code | Name                                 | LCD Display  | Parameter Setting |              | Setting Range | Unit |
|-------|------|--------------------------------------|--------------|-------------------|--------------|---------------|------|
| DRV   | 06   | Command source                       | Cmd Source   | 3                 | Int 485      | 0–5           | -    |
| COM   | 04   | Integrated communication inverter ID | Int485 St ID | 1                 |              | 1–250         | -    |
|       | 05   | Integrated communication protocol    | Int485 Proto | 0                 | ModBus RTU   | -             | -    |
|       | 06   | Integrated communication speed       | Int485 BaudR | 3                 | 9600 bps     | 1200–38400    | bps  |
|       | 07   | Integrated communication frame setup | Int485 Mode  | 0                 | D8 / PN / S1 | -             | -    |

## 7.6 Local/Remote Mode Switching

Local/remote mode switching is useful for checking the inverter’s operation, or to perform an inspection while retaining all parameter values. Also, in an emergency, it can also be used to override controls and operate the system manually using the keypad.

The [MULTI] key is a programmable key that can be configured to carry out multiple functions.

### ⓘ Caution

Use local/remote operation mode switching only when it is necessary. Improper mode switching may interrupt the inverter’s operation.

| Group | Code | Name                  | LCD Display   | Parameter Setting | Setting Range | Unit |
|-------|------|-----------------------|---------------|-------------------|---------------|------|
| CNF   | 42   | [MULTI] key functions | Multi-Key Sel | 2 Local/Remote    | -             | -    |
| DRV   | 06   | Command source        | Cmd Source    | 1 Fx/Rx-1         | 0–5           | -    |

### Local/Remote Mode Switching Setting Details

| Code                            | Description  |
|---------------------------------|--|
| CNF-42<br>[MULTI] key functions | <p>Set CNF-42 to “2(Local/Remote)” to perform local/remote mode switching using the [MULTI] key.</p> <p>Once the parameter is set, “R” (remote) is displayed on the keypad, and the inverter will automatically begin operating in remote mode. Changing from local to remote operation will not alter any previously configured parameter values and the operation of the inverter will not change.</p> <p>Press the [MULTI] key to switch the operation mode to “local.”<br/>“L” (local) is displayed on the keypad, and the command source and frequency source indication on the keypad (in MON mode) changes to “K/K.”<br/>The inverter stops operating if it was previously running in remote mode, and you can operate the inverter using the keypad.</p> <p>Press the [MULTI] key again to switch the operation mode back to “remote.”<br/>“R” (remote) is displayed again on the keypad, and the command source and frequency source indication on the keypad (in MON mode) changes according to the previous parameter settings.<br/>The inverter is now ready to operate in remote mode, and the inverter operation may vary depending on the type of input source.</p> |

### Note

#### Local/Remote Operation

- Full control of the inverter is available with the keypad during local operation.
- During local operation, jog commands will only work if one of the multi-function terminals (Px: P1–P11, codes IN-65–75) is set to “13 (RUN Enable)” and the relevant terminal is turned on.
- During remote operation, the inverter will operate according to the previously set frequency reference source and the command received from the input device.
- If ADV-10 (power-on run) is set to “0 (No)”, the inverter will not operate on power-on even when the following terminals are turned on:
  - Fwd/Rev run (Fx/Rx) terminal
  - Fwd/Rev jog terminal (Fwd jog/Rev Jog)
  - Pre-excitation terminal

To operate the inverter manually with the keypad, switch to local mode. Use caution when switching back to remote operation mode as the inverter will stop operating. If ADV-10 (power-on run) is set to “0 (No)”, a command through the input terminals will work only after all the terminals listed above have been turned off and then turned on again.

- If the inverter has been reset to clear a fault trip during an operation, the inverter will switch to local operation mode at power-on, and full control of the inverter will be with the keypad. The inverter will stop operating when operation mode is switched from “local” to “remote”. In this case, a run command through an input terminal will work only after all the input terminals have been turned off.

### Inverter Operation During Local/Remote Switching

Switching operation mode from “remote” to “local” while the inverter is running will cause the inverter to stop operating. Switching operation mode from “local” to “remote”, however, will cause the inverter to operate based on the command source:

- Analog commands via terminal input: The inverter will continue to run without interruption based on the command at the terminal block. If a reverse operation (Rx) signal is ON at the terminal block at startup, the inverter will operate in the reverse direction even if it was running in the forward direction in local operation mode before the reset.
- Digital source commands: All command sources, except terminal block command sources (which are analog sources), are digital command sources that include the keypad, LCD keypad, and communication sources. The inverter stops operating when switching to remote operation mode, and then starts operating when the next command is given.

## 7.7 Forward or Reverse Run Prevention

The rotation direction of motors can be configured to prevent motors from running in a forward or reverse direction. When reverse direction prevention is configured, pressing the [REV] key on the keypad will cause the motor to decelerate to 0 Hz and stop.

| Group | Code | Name                   | LCD Display | Parameter Setting |              | Setting Range | Unit |
|-------|------|------------------------|-------------|-------------------|--------------|---------------|------|
| ADV   | 09   | Run prevention options | Run Prevent | 0                 | None         | 0–2           | -    |
|       |      |                        |             | 1                 | Forward Prev |               |      |
|       |      |                        |             | 2                 | Reverse Prev |               |      |

**Forward/Reverse Run Prevention Setting Details**

| Code               | Description                    |              |                             |
|--------------------|--------------------------------|--------------|-----------------------------|
| ADV-09 Run Prevent | Choose a direction to prevent. |              |                             |
|                    | Setting                        |              | Description                 |
|                    | 0                              | None         | Do not set run prevention.  |
|                    | 1                              | Forward Prev | Set forward run prevention. |
|                    | 2                              | Reverse Prev | Set reverse run prevention. |

## 7.8 Power-on Run

The Power-on Run feature can be set up to start an inverter operation after powering up based on the run commands by terminal inputs (if they are configured).

**⚠ Caution**

Use caution when operating the inverter with Power-on Run enabled as the motor will begin rotating when the inverter starts up.

To enable Power-on Run, set DRV-06 (command source) to “1 (Fx/Rx-1)” or “2 (Fx/Rx-2)” and ADV-10 to “1”. If a run command via a terminal input is on, the inverter starts operating according to the terminal input settings as soon as it is turned on.

| Group | Code | Name           | LCD Display  | Parameter Setting |                    | Setting Range | Unit |
|-------|------|----------------|--------------|-------------------|--------------------|---------------|------|
| DRV   | 06   | Command source | Cmd Source   | 1, 2              | Fx/Rx-1 or Fx/Rx-2 | 0-5           | -    |
| ADV   | 10   | Power-on run   | Power-on Run | 1                 | Yes                | 0-1           | -    |

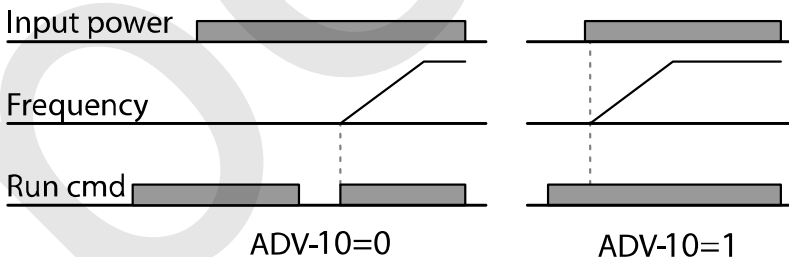

**Note**

- To prevent a repeat fault trip from occurring when a load, such as a fan, is free-running on a Power-on Run, set CON-71 (speed search options) bit 4 to “1”. The inverter will perform a speed search at the

beginning of the operation. If the speed search is not enabled, the inverter will start its operation in a normal V/F pattern and accelerate the motor.

- If the inverter has been turned on without Power-on Run enabled, the terminal block command must be first turned off, and then turned on again to begin the inverter's operation.

## 7.9 Reset and Restart

The reset and restart operations can be set up for inverter operation following a fault trip, based on the terminal block operation command (if it is configured).

### ⚠ Caution

- Use caution when operating the inverter with reset and restart enabled as the motor will begin rotating when the inverter starts up.
- Stop the frequency reference signal if you do not want the inverter to run again after a reset.

Set PRT-08 (RST Restart) to “1 (yes)” to allow the inverter to start operating after it is reset if a fault trip occurs. PRT-10 (Retry Delay) sets the delay time for a restart (the time the inverter will wait before it restarts).

The number of auto-restarts (PRT-09) refers to the number of times the inverter will try restarting its operation. If fault trips occur again after a restart, the retry number counts down each time the inverter restarts until the number becomes “0”. Once the inverter restarts successfully after the initial fault trip, the inverter does not restart until the next fault trip occurs. The number of auto-restarts set at PRT-09 that decreased after a restart reverts to the original setting value if successful operation continues for a certain period of time.

| Group | Code | Name                    | LCD Display  | Parameter Setting |         | Setting Range               | Unit |
|-------|------|-------------------------|--------------|-------------------|---------|-----------------------------|------|
| DRV   | 06   | Command source          | Cmd Source   | 1                 | Fx/Rx-1 | 1-2                         | -    |
|       |      |                         |              | 2                 | Fx/Rx-2 |                             |      |
| PRT   | 08   | Reset restart setup     | RST Restart  | 1                 | Yes     | No(0) [default]<br>/ Yes(1) | -    |
|       | 09   | No. of auto restart     | Retry Number | 1                 |         | 0-10                        | -    |
|       | 10   | Auto restart delay time | Retry Delay  | 1.0               |         | 0-60.0                      | sec  |

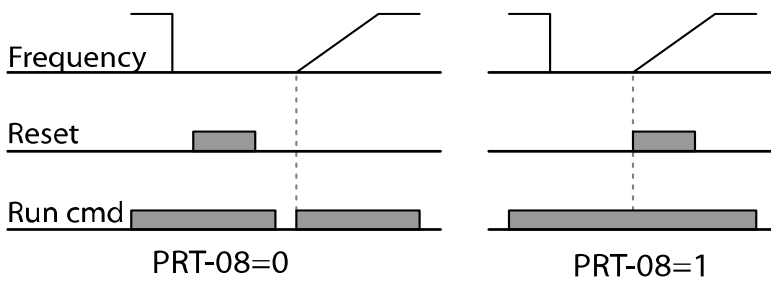
**Note**

- To prevent a repeat fault trip from occurring, set the CON-71 (Speed search options) bit 2 to “1”. The inverter will perform a speed search at the beginning of the operation. If the speed search is not enabled, the inverter will start its operation in a normal V/F pattern and accelerate the motor.
- If the inverter has been turned on without “reset and restart” enabled, the terminal block command must first be turned off and then turned on again to begin inverter operation.

## 7.10 Setting Acceleration and Deceleration Times

### 7.10.1 Acc/Dec Time Based on Maximum Frequency

Regardless of the operating frequency, acc/dec time values can be set based on the maximum frequency. To set acc/dec time values based on the maximum frequency, set BAS-08 (Acc/Dec reference) to “0 (Max Freq)”.

The acceleration time set at DRV-03 (Acceleration time) refers to the time required for the inverter to reach the maximum frequency from a stopped state (0 Hz). Likewise, the value set at DRV-04 (Deceleration time) refers to the time required to return to a stopped state (0 Hz) from the maximum frequency.

| Group | Code              | Name              | LCD Display | Parameter Setting |             | Setting Range       | Unit |
|-------|-------------------|-------------------|-------------|-------------------|-------------|---------------------|------|
| DRV   | 03                | Acceleration time | Acc Time    | 75 kW and less    | 20.0        | 0.0–600.0           | sec  |
|       |                   |                   |             | 90 kW and up      | 60.0        |                     |      |
|       | 04                | Deceleration time | Dec Time    | 75 kW and less    | 30.0        | 0.0–600.0           | sec  |
|       |                   |                   |             | 90 kW and up      | 90.0        |                     |      |
| 20    | Maximum frequency | Max Freq          | 60.00       |                   | 0.00–400.00 | Hz                  |      |
| BAS   | 08                | Acc/Dec reference | Ramp T Mode | 0                 | Max Freq    | Max Freq/Delta Freq | -    |
|       | 09                | Time scale        | Time scale  | 1                 | 0.1         | 0–2 (0.01/0.1/1)    | sec  |

### Acc/Dec Time Based on Maximum Frequency – Setting Details

| Code  | Description  |                                    |  |
|---|--|------------------------------------|--|
| BAS-08 Ramp T Mode  | Set BAS-08 to "0 (Max Freq)" to setup acc/dec time based on maximum frequency.   |                                    |  |
|   | Configuration  | Description                        |  |
|   | 0  | Max Freq                           | Set the acc/dec time based on the maximum frequency.   |
|   | 1  | Delta Freq                         | Set the acc/dec time based on the operating frequency. |
| <p>If, for example, the maximum frequency is 60.00 Hz, the acc/dec times are set to 5 seconds, and the frequency reference for operation is set at 30 Hz (half of 60 Hz). Therefore, the time required to reach 30 Hz is 2.5 seconds (half of 5 seconds).</p> |  |                                    |  |
| BAS-09 Time scale   | Use the time scale for all time-related values. It is particularly useful when more accurate acc/dec times are required, due to load characteristics, or when the maximum time range needs to be extended. |                                    |  |
|   | Configuration  | Description                        |  |
|   | 0  | 0.01 sec                           | Sets 0.01 second as the minimum unit.                  |
|   | 1  | 0.1 sec                            | Sets 0.1 second as the minimum unit.                   |
| 2   | 1 sec  | Sets 1 second as the minimum unit. |  |

**⚠ Caution**

Note that the range of maximum time values may change automatically when the units are changed. If for example, the acceleration time is set to 6000 seconds, a time scale change from 1 second to 0.01 second will result in a modified acceleration time of 60.00 seconds.

## 7.10.2 Acc/Dec Time Based on Operation Frequency

Acc/Dec times can be set based on the time required to reach the next frequency from the existing operation frequency. To set the acc/dec time values based on the existing operation frequency, set BAS-08 (Acc/Dec reference) to "1 (Delta Freq)".

| Group | Code | Name              | LCD Display | Settings       | Setting Range       | Unit |
|-------|------|-------------------|-------------|----------------|---------------------|------|
| DRV   | 03   | Acceleration time | Acc Time    | 20.0           | 0.0 - 600.0         | sec  |
|       | 04   | Deceleration time | Dec Time    | 30.0           | 0.0 - 600.0         | sec  |
| BAS   | 08   | Acc/Dec reference | Ramp T Mode | 1   Delta Freq | Max Freq/Delta Freq | -    |

### Acc/Dec Time Based on Operation Frequency– Setting Details

| Code   | Description  |  |             |              |  |                |  |
|--|--|--|-------------|--------------|--|----------------|--|
| BAS-08 Ramp T Mode   | Set BAS-08 to "1 (Delta Freq)" to set acc/dec times based on operation frequency.  |  |             |              |  |                |  |
|  | <table border="1"> <thead> <tr> <th>Configuration</th> <th>Description</th> </tr> </thead> <tbody> <tr> <td>0   Max Freq</td> <td>Set the acc/dec time based on the maximum frequency.</td> </tr> <tr> <td>1   Delta Freq</td> <td>Set the acc/dec time based on the operating frequency.</td> </tr> </tbody> </table> | Configuration  | Description | 0   Max Freq | Set the acc/dec time based on the maximum frequency. | 1   Delta Freq | Set the acc/dec time based on the operating frequency. |
|  | Configuration  | Description  |             |              |  |                |  |
|  | 0   Max Freq   | Set the acc/dec time based on the maximum frequency. |             |              |  |                |  |
| 1   Delta Freq   | Set the acc/dec time based on the operating frequency.   |  |             |              |  |                |  |
| If the acc/dec times are set to 5 seconds, and multiple frequency references are used in the operation in 2 steps, at 10 Hz and 30 Hz, each acceleration stage will take 5 seconds (refer to the graph below).   |  |  |             |              |  |                |  |
| <p>The graph plots Frequency (Hz) on the vertical axis against time (sec) on the horizontal axis. The frequency starts at 0 Hz. At 5 seconds, it reaches 10 Hz. At 12 seconds, it reaches 30 Hz. The time intervals for each acceleration stage are marked as 5 seconds. A 'Run cmd' bar is shown below the time axis, starting at 0 and ending at 12 seconds.</p> |  |  |             |              |  |                |  |



### 7.10.3 Multi-Step Acc/Dec Time Configuration

The acc/dec times can be configured via a multi-function terminal by setting the ACC (acceleration time) and DEC (deceleration time) codes in the DRV group.

| Group | Code       | Name                            | LCD Display                              | Parameter Setting |        | Setting Range | Unit |
|-------|------------|---------------------------------|--|-------------------|--------|---------------|------|
| DRV   | 03         | Acceleration time               | Acc Time                                 | 75 kW and less    | 20.0   | 0.0–600.0     | sec  |
|       |            |                                 |  | 90 kW and up      | 60.0   |               |      |
|       | 04         | Deceleration time               | Dec Time                                 | 75 kW and less    | 30.0   | 0.0–600.0     | sec  |
|       |            |                                 |  | 90 kW and up      | 90.0   |               |      |
| BAS   | 70, 72, 74 | Multi-step acceleration time1–3 | Acc Time–x                               | x.xx              |        | 0.0–600.0     | sec  |
|       | 71, 73, 75 | Multi-step deceleration time1–3 | Dec Time–x                               | x.xx              |        | 0.0–600.0     | sec  |
| IN    | 65–75      | Px terminal configuration       | Px Define (Px: P1–P8 [optional: P9–P11]) | 11                | XCEL-L | -             | -    |
|       |            |                                 |  | 12                | XCEL-M |               |      |
|       |            |                                 |  | 49                | XCEL-H |               |      |
|       | 89         | Multi-step command delay time   | In Check Time                            | 1                 |        | 1–5000        | ms   |

#### Acc/Dec Time Setup via Multi-function Terminals – Setting Details

| Code  | Description   |                   |             |           |                   |           |                   |           |                   |
|---|---|-------------------|-------------|-----------|-------------------|-----------|-------------------|-----------|-------------------|
| BAS-70, 72, 74<br>Acc Time 1–3  | Set multi-step acceleration time 1–3.   |                   |             |           |                   |           |                   |           |                   |
| BAS-71, 73, 75<br>Dec Time 1–3  | Set multi-step deceleration time 1–3.   |                   |             |           |                   |           |                   |           |                   |
| IN-65–75<br>Px Define (P1–P8<br>[optional P9–P11])  | Choose and configure the terminals to use for multi-step acc/dec time inputs.   |                   |             |           |                   |           |                   |           |                   |
|   | <table border="1"> <thead> <tr> <th>Configuration</th> <th>Description</th> </tr> </thead> <tbody> <tr> <td>11 XCEL-L</td> <td>Acc/Dec command-L</td> </tr> <tr> <td>12 XCEL-M</td> <td>Acc/Dec command-M</td> </tr> <tr> <td>49 XCEL-H</td> <td>Acc/Dec command-H</td> </tr> </tbody> </table> | Configuration     | Description | 11 XCEL-L | Acc/Dec command-L | 12 XCEL-M | Acc/Dec command-M | 49 XCEL-H | Acc/Dec command-H |
|   | Configuration   | Description       |             |           |                   |           |                   |           |                   |
|   | 11 XCEL-L   | Acc/Dec command-L |             |           |                   |           |                   |           |                   |
|   | 12 XCEL-M   | Acc/Dec command-M |             |           |                   |           |                   |           |                   |
| 49 XCEL-H   | Acc/Dec command-H   |                   |             |           |                   |           |                   |           |                   |
| acc/dec commands are recognized as binary code inputs and will control the acceleration and deceleration based on parameter values set at BAS-70–75 |   |                   |             |           |                   |           |                   |           |                   |
| If, for example, the P7 and P8 terminals are set as XCEL-L and XCEL-M respectively, the following operation will be available.                      |   |                   |             |           |                   |           |                   |           |                   |

| Code                | Description  |              |    |    |   |   |   |   |   |   |   |   |   |   |   |   |
|---------------------|--|--------------|----|----|---|---|---|---|---|---|---|---|---|---|---|---|
|                     | <table border="1"> <thead> <tr> <th>Acc/Dec time</th> <th>P8</th> <th>P7</th> </tr> </thead> <tbody> <tr> <td>0</td> <td>-</td> <td>-</td> </tr> <tr> <td>1</td> <td>-</td> <td>✓</td> </tr> <tr> <td>2</td> <td>✓</td> <td>-</td> </tr> <tr> <td>3</td> <td>✓</td> <td>✓</td> </tr> </tbody> </table> <p>[Multi-function terminal P7, P8 configuration]</p> | Acc/Dec time | P8 | P7 | 0 | - | - | 1 | - | ✓ | 2 | ✓ | - | 3 | ✓ | ✓ |
| Acc/Dec time        | P8   | P7           |    |    |   |   |   |   |   |   |   |   |   |   |   |   |
| 0                   | -  | -            |    |    |   |   |   |   |   |   |   |   |   |   |   |   |
| 1                   | -  | ✓            |    |    |   |   |   |   |   |   |   |   |   |   |   |   |
| 2                   | ✓  | -            |    |    |   |   |   |   |   |   |   |   |   |   |   |   |
| 3                   | ✓  | ✓            |    |    |   |   |   |   |   |   |   |   |   |   |   |   |
| IN-89 In Check Time | Set the time for the inverter to check for other terminal block inputs. If IN-89 is set to 100 ms and a signal is supplied to the P6 terminal, the inverter searches for other inputs over the next 100 ms. When the time expires, the acc/dec time will be set based on the input received at P6.   |              |    |    |   |   |   |   |   |   |   |   |   |   |   |   |

### 7.10.4 Configuring Acc/Dec Time Switch Frequency

By configuring the switch frequency, you can switch between two different sets of acc/dec times (acc/dec gradients) without configuring the multi-function terminals.

| Group | Code | Name                          | LCD Display    | Parameter Setting | Setting Range       | Unit   |
|-------|------|-------------------------------|----------------|-------------------|---------------------|--------|
| DRV   | 03   | Acceleration time             | Acc Time       | 10.0              | 0.0–600.0           | sec    |
|       | 04   | Deceleration time             | Dec Time       | 10.0              | 0.0–600.0           | sec    |
| BAS   | 70   | Multi-step acceleration time1 | Acc Time-1     | 20.0              | 0.0–600.0           | sec    |
|       | 71   | Multi-step deceleration time1 | Dec Time-1     | 20.0              | 0.0–600.0           | sec    |
| ADV   | 60   | Acc/dec time switch frequency | Xcel Change Fr | 30.00             | 0–Maximum frequency | Hz/RPM |

Acc/Dec Time Switch Frequency Setting Details

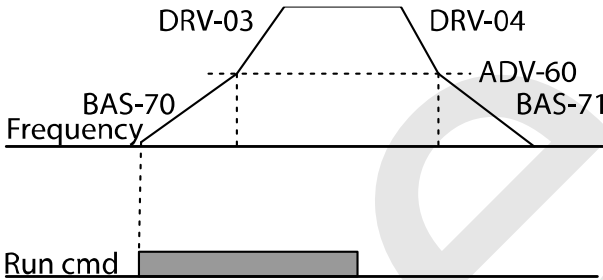
| Code                             | Description  |
|----------------------------------|--|
| <p>ADV-60<br/>Xcel Change Fr</p> | <p>After the acc/dec switch frequency has been set, the acc/dec gradients configured at BAS-70 and 71 will be used when the inverter's operation frequency is at or below the switch frequency. If the operation frequency exceeds the switch frequency, the gradient level configured for the acceleration and deceleration times (set at DRV-03 and DRV-04) will be used.</p> <p>If you configure the P1–P8 [optional: P9–P11] multi-function input terminals for multi-step acc/dec gradients (XCEL-L, XCEL-M, XCEL-H), the inverter will operate based on the acc/dec inputs at the terminals regardless of the acc/dec switch frequency configurations.</p>  <p>The diagram illustrates the relationship between the inverter's operation frequency and the acceleration/deceleration gradients. The top curve shows the frequency profile: it begins at a low level (BAS-70), accelerates through a region defined by DRV-03, reaches a peak, and then decelerates through a region defined by DRV-04, ending at a low level (BAS-71). A horizontal line indicates the switch frequency, which is set to ADV-60. The Run cmd signal is shown as a shaded rectangular pulse at the bottom, indicating the period during which the frequency profile is active.</p> |

## 7.11 Acc/Dec Pattern Configuration

The acc/dec gradient level patterns can be configured to enhance and smooth out the inverter's acceleration and deceleration curves. A linear pattern features a linear increase or decrease to the output frequency, at a fixed rate. An S-curve pattern offers a smoother and more gradual increase or decrease of output frequency, ideal for lift-type loads or elevator doors, etc. The S-curve gradient level can be adjusted using codes ADV-03–06 in the advanced group.

| Group | Code                       | Name                       | LCD Display | Parameter Setting |          | Setting Range | Unit |
|-------|----------------------------|----------------------------|-------------|-------------------|----------|---------------|------|
| BAS   | 08                         | Acc/dec reference          | Ramp T mode | 0                 | Max Freq | 0–1           | -    |
| ADV   | 01                         | Acceleration pattern       | Acc Pattern | 0                 | Linear   | 0–1           | -    |
|       |                            |                            |             | 1                 | S-curve  |               |      |
|       | 02                         | Deceleration pattern       | Dec Pattern | 0                 | Linear   | 0–1           | -    |
|       |                            |                            |             | 1                 | S-curve  |               |      |
|       | 03                         | S-curve acc start gradient | Acc S Start | 40                |          | 1–100         | %    |
|       | 04                         | S-curve acc end gradient   | Acc S End   | 40                |          | 1–100         | %    |
| 05    | S-curve dec start gradient | Dec S Start                | 40          |                   | 1–100    | %             |      |
| 06    | S-curve dec end gradient   | Dec S End                  | 40          |                   | 1–100    | %             |      |

### Acc/Dec Pattern Setting Details

| Code               | Description   |
|--------------------|---|
| ADV-03 Acc S Start | <p>Sets the gradient level as acceleration starts when using an S-curve, acc/dec pattern. ADV-03 defines the S-curve gradient level as a percentage up to half of the total acceleration.</p> <p>If the frequency reference and maximum frequency are set at 60 Hz and ADV-03 is set to 50%, ADV-03 configures the acceleration up to 30 Hz (half of 60 Hz). The inverter will perform S-curve acceleration in the 0-15 Hz frequency range (50% of 30 Hz). Linear acceleration will be applied to the remaining acceleration within the 15–30 Hz frequency range.</p> |
| ADV-04 Acc S End   | <p>Sets the gradient level as acceleration ends when using an S-curve acc/dec pattern. ADV-03 defines S-curve gradient level as a percentage, above half of the total acceleration.</p> <p>If the frequency reference and the maximum frequency are set at 60 Hz and ADV-04 is set to 50%, setting ADV-04 configures acceleration to increase from 30 Hz (half of 60 Hz) to 60 Hz (end of acceleration). Linear acceleration will be applied within the 30-45 Hz frequency range. The inverter will perform an S-curve</p>  |

## Basic Functions

| Code  | Description  |
|---|--|
|   | acceleration for the remaining acceleration in the 45–60 Hz frequency range.   |
| ADV-05 Dec S Start<br>–<br>ADV-06 Dec S End | Sets the rate of S-curve deceleration. Configuration for codes ADV-05 and ADV-06 may be performed the same way as configuring codes ADV-03 and ADV-04. |

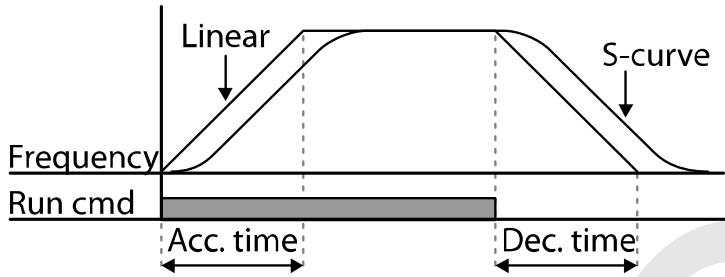

[Acceleration / deceleration pattern configuration]

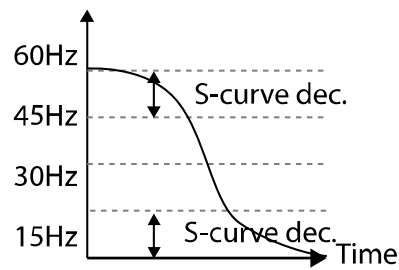
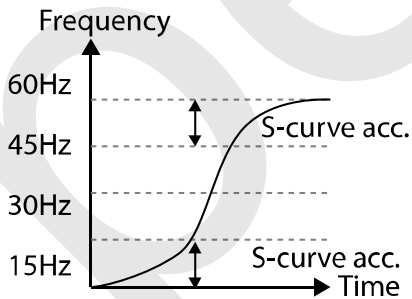
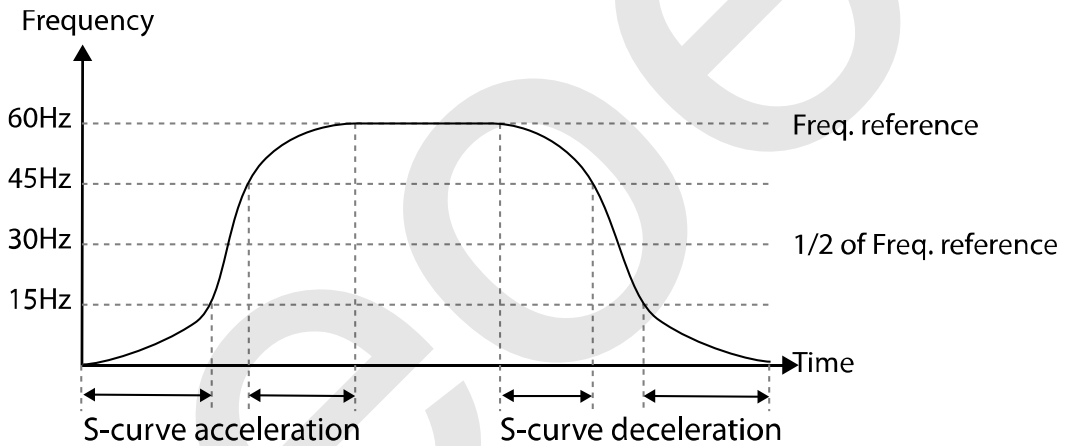

[Acceleration / deceleration S-curve pattern configuration]

**Note****The actual acc/dec time during an S-curve application**

The actual acceleration time = user-configured acceleration time + user-configured acceleration time x starting gradient level/2 + user-configured acceleration time x ending gradient level/2.

The actual deceleration time = user-configured deceleration time + user-configured deceleration time x starting gradient level/2 + user-configured deceleration time x ending gradient level/2.

**⚠ Caution**

Note that actual acc/dec times become greater than the user-defined acc/dec times when S-curve acc/dec patterns are in use.

## 7.12 Stopping the Acc/Dec Operation

Configure the multi-function input terminals to stop acceleration or deceleration and operate the inverter at a fixed frequency.

| Group | Code  | Name                      | LCD Display                              | Parameter Setting |           | Setting Range | Unit |
|-------|-------|---------------------------|--|-------------------|-----------|---------------|------|
| IN    | 65–75 | Px terminal configuration | Px Define (Px: P1–P8 [optional: P9–P11]) | 25                | XCEL Stop | 0–51          | -    |

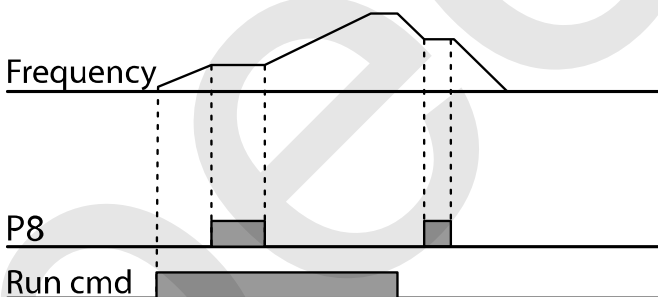

## 7.13 V/F (Voltage/Frequency) Control

Configure the inverter's output voltages, gradient levels, and output patterns to achieve a target output frequency with the V/F control. The amount of torque boost used during low frequency operations can also be adjusted.

### 7.13.1 Linear V/F Pattern Operation

A linear V/F pattern configures the inverter to increase or decrease the output voltage at a fixed rate for different operation frequencies based on V/F characteristics. A linear V/F pattern is particularly useful when a constant torque load is applied.

| Group | Code | Name            | LCD Display  | Parameter Setting |        | Setting Range | Unit |
|-------|------|-----------------|--------------|-------------------|--------|---------------|------|
| DRV   | 09   | Control mode    | Control Mode | 0                 | V/F    | -             | -    |
|       | 18   | Base frequency  | Base Freq    | 60.00             |        | 30.00–400.00  | Hz   |
|       | 19   | Start frequency | Start Freq   | 0.50              |        | 0.01–10.00    | Hz   |
| BAS   | 07   | V/F pattern     | V/F Pattern  | 0                 | Linear | -             | -    |

#### Linear V/F Pattern Setting Details

| Code              | Description   |
|-------------------|---|
| DRV-18 Base Freq  | Sets the base frequency. A base frequency is the inverter's output frequency when running at its rated voltage. Refer to the motor's rating plate to set this parameter value.  |
| DRV-19 Start Freq | <p>Sets the start frequency. A start frequency is a frequency at which the inverter starts voltage output. The inverter does not produce an output voltage while the frequency reference is lower than the set frequency. However, if a deceleration stop is made while operating above the start frequency, the output voltage will continue until the operation frequency reaches a full stop (0 Hz).</p> |

### 7.13.2 Square Reduction V/F Pattern Operation

Square reduction V/F pattern is ideal for loads such as fans and pumps. It provides non-linear acceleration and deceleration patterns to sustain torque throughout the entire frequency range.

| Group | Code | Name        | LCD Display | Parameter Setting |         | Setting Range | Unit |
|-------|------|-------------|-------------|-------------------|---------|---------------|------|
| BAS   | 07   | V/F pattern | V/F Pattern | 1                 | Square  | 0-3           | -    |
|       |      |             |             | 3                 | Square2 |               |      |

**Square Reduction V/F pattern Operation - Setting Details**

| Code               | Description  |          |          |   |   |   |  |
|--------------------|--|----------|----------|---|---|---|--|
| BAS-07 V/F Pattern | Sets the parameter value to “1 (Square)” or “2 (Square2)” depending on the load’s start characteristics.   |          |          |   |   |   |  |
|                    | <table border="1"> <thead> <tr> <th>Setting</th> <th>Function</th> </tr> </thead> <tbody> <tr> <td>1</td> <td>Square<br/>The inverter produces an output voltage proportionate to 1.5 square of the operation frequency.</td> </tr> <tr> <td>3</td> <td>Square2<br/>The inverter produces an output voltage proportionate to 2 square of the operation frequency. This setup is ideal for variable torque loads, such as fans or pumps.</td> </tr> </tbody> </table> | Setting  | Function | 1 | Square<br>The inverter produces an output voltage proportionate to 1.5 square of the operation frequency. | 3 | Square2<br>The inverter produces an output voltage proportionate to 2 square of the operation frequency. This setup is ideal for variable torque loads, such as fans or pumps. |
|                    | Setting  | Function |          |   |   |   |  |
| 1                  | Square<br>The inverter produces an output voltage proportionate to 1.5 square of the operation frequency.  |          |          |   |   |   |  |
| 3                  | Square2<br>The inverter produces an output voltage proportionate to 2 square of the operation frequency. This setup is ideal for variable torque loads, such as fans or pumps.   |          |          |   |   |   |  |

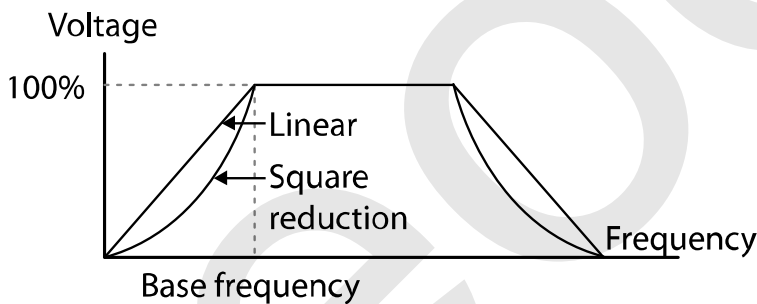



### 7.13.3 User V/F Pattern Operation

The iS7 inverter allows the configuration of user-defined V/F patterns to suit the load characteristics of a specific motor.

| Group | Code | Name             | LCD Display | Parameter Setting |          | Setting Range       | Unit |
|-------|------|------------------|-------------|-------------------|----------|---------------------|------|
| BAS   | 07   | V/F pattern      | V/F Pattern | 2                 | User V/F | 0–2                 | -    |
|       | 41   | User frequency 1 | User Freq 1 | 15.00             |          | 0–Maximum frequency | Hz   |
|       | 42   | User voltage 1   | User Volt 1 | 25                |          | 0–100%              | %    |
|       | 43   | User frequency 2 | User Freq 2 | 30.00             |          | 0–Maximum frequency | Hz   |
|       | 44   | User voltage 2   | User Volt 2 | 50                |          | 0–100%              | %    |
|       | 45   | User frequency 3 | User Freq 3 | 45.00             |          | 0–Maximum frequency | Hz   |
|       | 46   | User voltage 3   | User Volt 3 | 75                |          | 0–100%              | %    |
|       | 47   | User frequency 4 | User Freq 4 | 60                |          | 0–Maximum frequency | Hz   |
|       | 48   | User voltage 4   | User Volt 4 | 100               |          | 0–100%              | %    |

#### User V/F pattern Setting Details

| Code                                      | Description  |
|---|--|
| BAS-41 User Freq 1<br>–BAS-48 User Volt 4 | Sets the parameter values to assign user-defined frequencies (User Freq x) for the start and maximum frequencies. Voltages can also be set to correspond with each frequency, and for each user voltage (User Volt x). |

The 100% output voltage in the figure below is based on the parameter settings of BAS-15 (motor rated voltage). If BAS-15 is set to "0," it will be based on the input voltage.

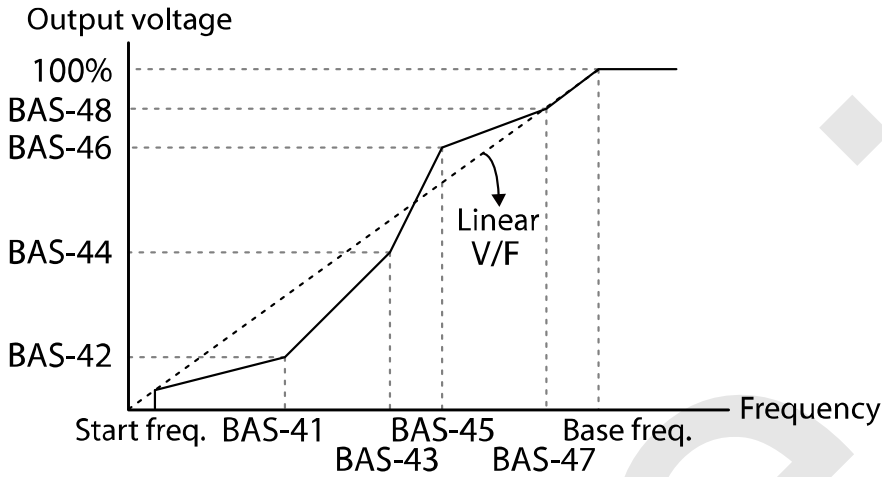

### ⚠ Caution

- When a normal induction motor is in use, care must be taken not to change the output pattern from a linear V/F pattern. Non-linear V/F patterns may cause insufficient motor torque or motor overheating due to over-excitation.
- When a user V/F pattern is in use, the forward torque boost (DRV-16) and reverse torque boost (DRV-17) will not operate.

## 7.14 Torque Boost

### 7.14.1 Manual Torque Boost

Manual torque boost enables users to adjust the output voltage during low-speed operation or motor start. You can increase the low-speed torque or improve motor-starting properties by manually increasing the output voltage. Configure the manual torque boost while running loads that require a high starting torque, such as lift-type loads.

| Group | Code | Name                 | LCD Display  | Parameter Setting |        | Setting Range | Unit |
|-------|------|----------------------|--------------|-------------------|--------|---------------|------|
| DRV   | 15   | Torque boost options | Torque Boost | 0                 | Manual | 0–1           | -    |
|       | 16   | Forward torque boost | Fwd Boost*   | 2.0               |        | 0.0–15.0      | %    |
|       | 17   | Reverse torque boost | Rev Boost*   | 2.0               |        | 0.0–15.0      | %    |

\* For 90 kW–160 kW model types, the default setting value is 1.0 [%].

#### Manual Torque Boost Setting Details

| Code             | Description                                  |
|------------------|--|
| DRV-16 Fwd Boost | Sets the torque boost for forward operation. |
| DRV-17 Rev Boost | Sets the torque boost for reverse operation. |

Output Voltage = Output voltage affected by DRV-16,17 Manual torque boost parameter  
 = V/F voltage + Boosted voltage  
 = (Maximum voltage - Boosted voltage) ×  $\frac{\text{Current frequency}}{\text{Base frequency}}$  + Boosted voltage

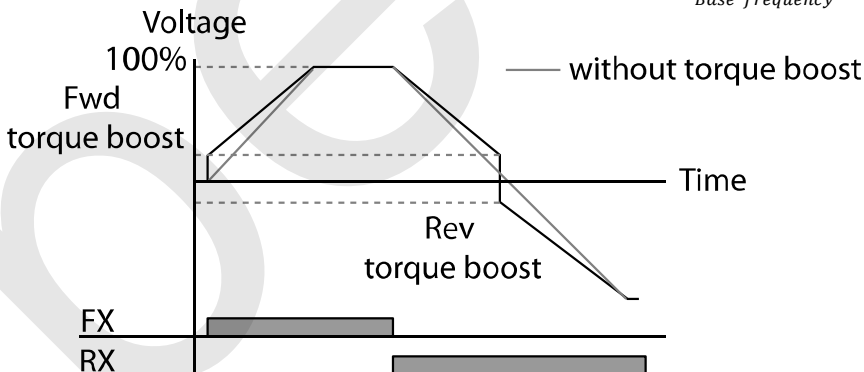

#### ⚠ Caution

Excessive torque boost will result in over-excitation and motor overheating.

## 7.14.2 Auto Torque Boost

Set DRV-15 to “1 (Auto)” to enable auto torque boost. While manual torque boost adjusts the inverter output based on the setting values, regardless of the type of load used during the operation, auto torque boost enables the inverter to automatically calculate the amount of output voltage required for the torque boost based on the entered motor parameters.

Because auto torque boost requires motor-related parameters, such as stator resistance, inductance, and no-load current, auto tuning (BAS-20) has to be performed before the auto torque boost can be configured. Similarly to manual torque boost, configure auto torque boost while running a load that requires high starting torque, such as lift-type loads. Refer to [8.9 Auto Tuning](#) on page [220](#).

| Group | Code | Name              | LCD Display  | Parameter Setting |           | Setting Range | Unit |
|-------|------|-------------------|--------------|-------------------|-----------|---------------|------|
| DRV   | 15   | Torque boost mode | Torque Boost | 1                 | Auto      | 0–2           | -    |
| BAS   | 20   | Auto tuning       | Auto Tuning  | 2                 | Rs+Lsigma | 0–3           | -    |

## 7.14.3 Advanced Auto Torque Boost

Manual Torque Boost, regardless of load characteristics, outputs the inverter voltage according to the torque boost amount set by the user. Auto Torque Boost automatically calculates the boost amount, but auto tuning the motor is required. For Advanced Auto Torque Boost, the inverter outputs the inverter voltage by adjusting the boost amount according to the load itself without auto tuning the motor.

Advanced Automatic Torque Boost is adjusted according to the load determined by the Adv ATB M Gain, Adv ATB G Gain of DRV-27 and 28 values and it can be used when starting torque is insufficient or when excessive current flows..

| Group | Code | Name                        | LCD Display    | Parameter Setting |               | Setting Range | Unit |
|-------|------|-----------------------------|----------------|-------------------|---------------|---------------|------|
| DRV   | 15   | Torque boost mode           | Torque Boost   | 2                 | Advanced Auto | 0–2           | -    |
|       | 16   | Fwd Boost <sup>Note1)</sup> | Fwd Boost      | 2.0               |               | 0-15          | %    |
|       | 17   | Rev Boost <sup>Note2)</sup> | Rev Boost      | 2.0               |               | 0-15          | %    |
|       | 26   | Adv ATB Filter              | Adv ATB Filter | 100               |               | 1-1000        | msec |
|       | 27   | Adv ATB M Gain              | Adv ATB M Gain | 50.0              |               | 0-300.0       | %    |
|       | 28   | Adv ATB G Gain              | Adv ATB G Gain | 50.0              |               | 0-300.0       | %    |

\* Note 1, Note 2) For 90 kW – 160 kW products, the factory shipment value is 1.0 [%].

### Advanced Auto Torque Boost Setting Details

| Code | Description |
|------|-------------|
|------|-------------|

| Code                  | Description  |
|-----------------------|--|
| DRV-16 Fwd Boost      | Adjusts the torque boost amount for forward rotation           |
| DRV-17 Rev Boost      | Adjusts the torque boost amount for reverse rotation.          |
| DRV-26 Adv ATB Filter | Filter gain for calculating the Auto Torque Boost value.       |
| DRV-27 Adv ATB M Gain | Gain for calculating the reverse Auto Torque Boost value.      |
| DRV-28 Adv ATB G Gain | Gain for calculating the regeneration Auto Torque Boost value. |

If there is no load, the additional voltage amount due to Auto Torque Boost is 0, which gives the same result as the normal manual boost.

When the load is applied, the amount of compensation voltage varies depending on the operation and reverse directions.

If you set the DRV-16 and DRV-17 values differently when using Advanced Auto Torque Boost at no load, a current hunting operation may occur.

### **Output voltage = Primary output voltage + Secondary output voltage**

#### **· Primary output voltage**

= Output voltage affected by DRV-16,17 Manual torque boost parameter

$$= (\text{Maximum voltage} - \text{Boosted voltage}) \times \frac{\text{Current frequency}}{\text{Base frequency}} + \text{Boosted voltage}$$

#### **· Secondary output voltage**

= Output voltage affected by DRV-27,28 ATB M/G Gain parameter and motor load

$$= \text{Motor rated slip frequency} \times \frac{\text{Motor max phase voltage}}{\text{Base frequency}} \times \text{ATB M/G Gain} \times \frac{\text{Current output current}}{\text{Motor rated current}}$$

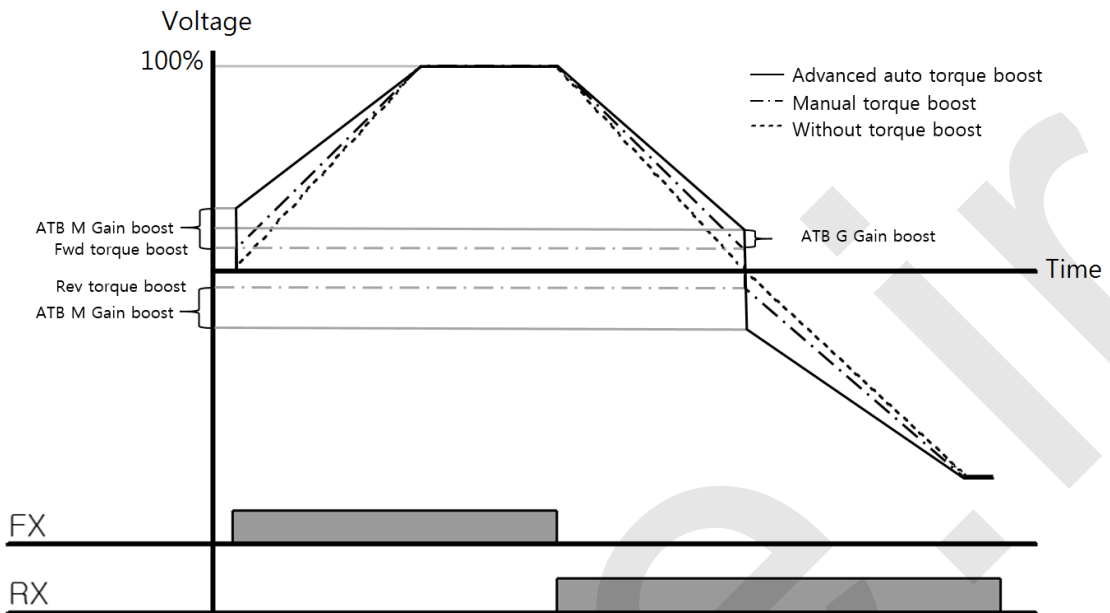

**ⓘ Caution**

If the torque boost amount is set too large, overheating of the motor due to over-excitation will occur.

## 7.15 Output Voltage Setting

Output voltage settings are required when a motor's rated voltage differs from the input voltage to the inverter. Set BAS-15 to configure the motor's rated operating voltage. The set voltage becomes the output voltage of the inverter's base frequency. When the inverter operates above the base frequency, and when the motor's voltage rating is lower than the input voltage at the inverter, the inverter adjusts the voltage and supplies the motor with the voltage set at BAS-15 (motor-rated voltage). If the motor's rated voltage is higher than the input voltage at the inverter, the inverter will supply the inverter input voltage to the motor.

If BAS-15 (motor-rated voltage) is set to "0," the inverter corrects the output voltage based on the input voltage in the stopped condition. If the frequency is higher than the base frequency and when the input voltage is lower than the parameter setting, the input voltage will be the inverter output voltage.

| Group | Code | Name                | LCD Display | Parameter Setting | Setting Range | Unit |
|-------|------|---------------------|-------------|-------------------|---------------|------|
| BAS   | 15   | Motor rated voltage | Rated Volt  | 220               | 0, 180-480    | V    |

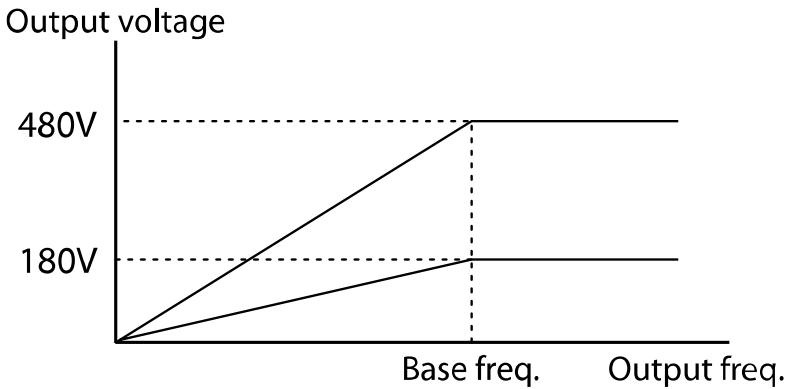

## 7.16 Start Mode Setting

Select the start mode to use when the operation command is input with the motor in the stopped condition.

### 7.16.1 Acceleration Start

Acceleration start is a general acceleration mode. If there are no extra settings applied, the motor accelerates directly to the frequency reference when the command is input.

| Group | Code | Name       | LCD Display | Parameter Setting |     | Setting Range | Unit |
|-------|------|------------|-------------|-------------------|-----|---------------|------|
| ADV   | 07   | Start mode | Start mode  | 0                 | Acc | -             | -    |

### 7.16.2 Start After DC Braking

This start mode supplies a DC voltage for a set amount of time to provide DC braking before an inverter starts to accelerate a motor. If the motor continues to rotate due to inertia, DC braking will stop the motor, allowing the motor to accelerate from a stop. DC braking can also be used with a mechanical brake connected to a motor shaft when a constant torque load is applied, if a constant torque is required after the mechanical brake is released.

| Group | Code | Name                  | LCD Display   | Parameter Setting |          | Setting Range | Unit |
|-------|------|-----------------------|---------------|-------------------|----------|---------------|------|
| ADV   | 07   | Start mode            | Start Mode    | 1                 | DC-Start | -             | -    |
|       | 12   | Start DC braking time | DC-Start Time | 0.00              |          | 0.00–60.00    | sec  |
|       | 13   | DC Injection Level    | DC Inj Level  | 50                |          | 0–200         | %    |

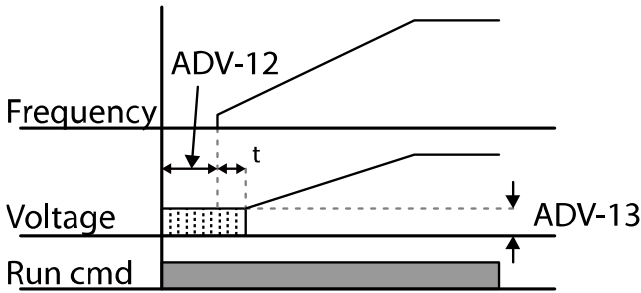

**⚠ Caution**

The amount of DC braking required is based on the motor's rated current. Do not use DC braking resistance values that can cause current draw to exceed the rated current of the inverter. If the DC braking resistance is too high or brake time is too long, the motor may overheat or be damaged.

## 7.17 Stop Mode Setting

Select Stop mode to stop the inverter operation.

### 7.17.1 Deceleration Stop

Deceleration stop is a general stop mode. If there are no extra settings applied, the motor decelerates to 0 Hz and stops, as shown in the figure below.

| Group | Code | Name      | LCD Display | Parameter Setting | Setting Range | Unit |
|-------|------|-----------|-------------|-------------------|---------------|------|
| ADV   | 08   | Stop mode | Stop Mode   | 0    Dec          | -             | -    |

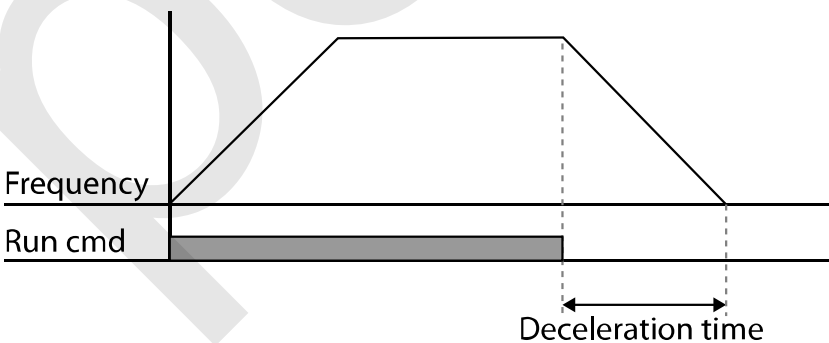



### 7.17.2 Stop after DC Braking

When the operation frequency reaches the set value during deceleration (DC braking frequency) the inverter stops the motor by supplying DC power to the motor. With a stop command input, the inverter begins decelerating the motor. When the frequency reaches the DC braking frequency set at ADV-17, the inverter supplies DC voltage to the motor and stops it.

| Group | Code | Name                             | LCD Display    | Parameter Setting |     | Setting Range | Unit |
|-------|------|----------------------------------|----------------|-------------------|-----|---------------|------|
| ADV   | 08   | Stop mode                        | Stop Mode      | 0                 | Dec | 0-4           | -    |
|       | 14   | Output block time before braking | DC-Block Time  | 0.10              |     | 0.00-60.00    | sec  |
|       | 15   | DC braking time                  | DC-Brake Time  | 1.00              |     | 0-60          | sec  |
|       | 16   | DC braking amount                | DC-Brake Level | 50                |     | 0-200         | %    |
|       | 17   | DC braking frequency             | DC-Brake Freq  | 5.00              |     | 0.00-60.00    | Hz   |

#### Note

DC braking does not produce stop torque. Install appropriate peripheral devices if stop torque is required in your application.

#### DC Braking After Stop Setting Details

| Code                  | Description  |
|-----------------------|--|
| ADV-14 DC-Block Time  | Sets the time to block the inverter output before DC braking. If the inertia of the load is great, or if the DC braking frequency (ADV-17) is set too high, a fault trip may occur due to overcurrent conditions when the inverter supplies DC voltage to the motor. Prevent overcurrent fault trips by adjusting the output block time before DC braking. |
| ADV-15 DC-Brake Time  | Sets the time duration for the DC voltage supply to the motor.   |
| ADV-16 DC-Brake Level | Sets the amount of DC braking to apply. The parameter setting is based on the rated current of the motor.  |
| ADV-17 DC-Brake Freq  | Sets the frequency to start DC braking. When the frequency is reached, the inverter starts deceleration. If the dwell frequency is set lower than the DC braking frequency, the dwell operation will not work and DC braking will start instead.   |

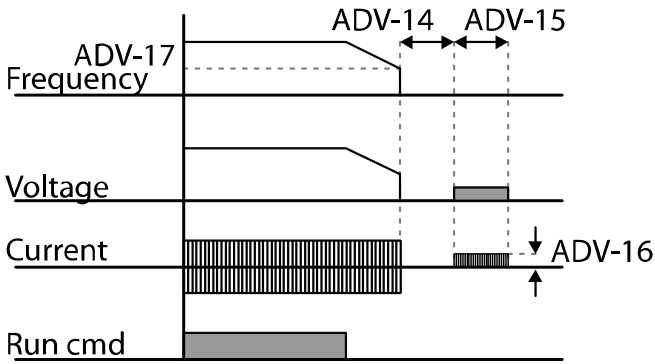

**⚠ Caution**

- The motor can overheat or be damaged if an excessive amount of DC braking is applied to the motor or if the DC braking time is set to a high value.
- DC braking is configured based on the motor's rated current. To prevent overheating or damaging motors, do not set the current value higher than the inverter's rated current.

**7.17.3 Free Run Stop**

When the operation command is off, the inverter output turns off, and the load stops due to residual inertia.

| Group | Code | Name      | LCD Display | Parameter Setting | Setting Range | Unit |
|-------|------|-----------|-------------|-------------------|---------------|------|
| ADV   | 08   | Stop mode | Stop Mode   | 2                 | Free-Run      | 0-4  |

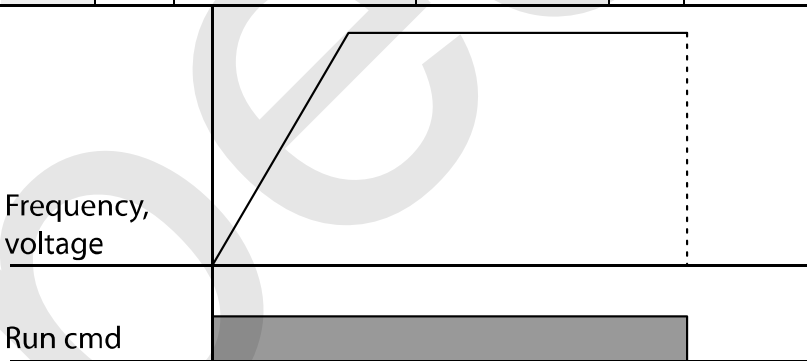

**⚠ Caution**

When there is high inertia on the output side and the motor is operating at high speed, the load's inertia will cause the motor to continue rotating even after the inverter output is blocked.

## 7.17.4 Power Braking

When the inverter's DC voltage rises above a specified level due to motor-regenerated energy, a control is made to either adjust the deceleration gradient level or reaccelerate the motor in order to reduce the regenerated energy. Power braking can be used when short deceleration times are needed without braking resistors, or when optimum deceleration is needed without causing an over voltage fault trip.

| Group | Code | Name      | LCD Display | Parameter Setting |               | Setting Range | Unit |
|-------|------|-----------|-------------|-------------------|---------------|---------------|------|
| ADV   | 08   | Stop mode | Stop Mode   | 4                 | Power Braking | -             | -    |

### ⚠ Caution

- To prevent overheating or damaging the motor, do not apply power braking to loads that require frequent deceleration.
- Stall prevention and power braking only operate during deceleration, and power braking takes priority over stall prevention. In other words, when both bit 3 of PRT-50 (stall prevention and flux braking) and ADV-08 (braking options) are set, power braking will take precedence.
- Note that if the deceleration time is too short or the inertia of the load is too great, an overvoltage fault trip may occur.
- Note that if a free run stop is used, the actual deceleration time may be longer than the preset deceleration time.

## 7.18 Frequency Limit

The operation frequency can be limited by setting a maximum frequency, start frequency, upper limit frequency, and lower limit frequency.

### 7.18.1 Frequency Limit Using Maximum Frequency and Start Frequency

| Group | Code | Name              | LCD Display | Parameter Setting | Setting Range | Unit |
|-------|------|-------------------|-------------|-------------------|---------------|------|
| DRV   | 19   | Start frequency   | Start Freq  | 0.50              | 0.01–10.00    | Hz   |
|       | 20   | Maximum frequency | Max Freq    | 60.00             | 40.00–400.00  | Hz   |

#### Frequency Limit Using Maximum Frequency and Start Frequency - Setting Details

| Code              | Description   |
|-------------------|---|
| DRV-19 Start Freq | Sets the lower limit value for all speed unit parameters that are expressed in Hz or rpm. Any operation frequency input that is lower than the start frequency is treated as a 0 Hz input.                  |
| DRV-20 Max Freq   | Sets an upper limit frequency to all speed unit parameters that are expressed in Hz or rpm, except for the base frequency (DRV-18). An operation frequency cannot be set higher than the maximum frequency. |

### 7.18.2 Frequency Limit Using Upper and Lower Limit Frequency Values

| Group | Code | Name                        | LCD Display    | Parameter Setting |             | Setting Range         | Unit |
|-------|------|-----------------------------|----------------|-------------------|-------------|-----------------------|------|
| ADV   | 24   | Frequency limit             | Freq Limit     | 0                 | --- No ---  | No/Yes                | -    |
|       | 25   | Frequency lower limit value | Freq Limit Lo  | 0.50              |             | 0.0–maximum frequency | Hz   |
|       | 26   | Frequency upper limit value | Freq Limit Hi  | 60.00             |             | 0.5–maximum frequency | Hz   |
|       | 34   | Jog Frequency Limit         | Jog Freq Limit | 1                 | --- Yes --- | No/Yes                | -    |

**Frequency Limit Using Upper and Lower Limit Frequencies - Setting Details**

| Code   | Description   |
|--|---|
| ADV-24 Freq Limit                            | The initial setting is "0 (No)." Changing the setting to "1 (Yes)" allows you to set the lower limit frequency (ADV-25) and the upper limit frequency (ADV-26). When the setting is "0 (No)", codes ADV-25 and ADV-26 are not visible.  |
| ADV-25 Freq Limit Lo<br>ADV-26 Freq Limit Hi | Sets upper and lower frequency limits. All frequency selections are restricted to frequencies from within the upper and lower limits. This restriction also applies when you in input a frequency reference using the keypad.   |
| ADV-34 Jog Freq Limit                        | This code allows you to select whether to use the frequency limit function with frequency upper/lower limits for jog operations. When ADV-34 is set to "Yes", the frequency limit is applied if the frequency limit function using the frequency upper/lower limits is set the same as a normal operation for jog operations. When ADV-34 is set to "No", the frequency limit value is not applied even if the frequency limit function using the frequency upper/lower limits is set for jog operations. However, the frequency limit for the maximum frequency and the start frequency applies. |

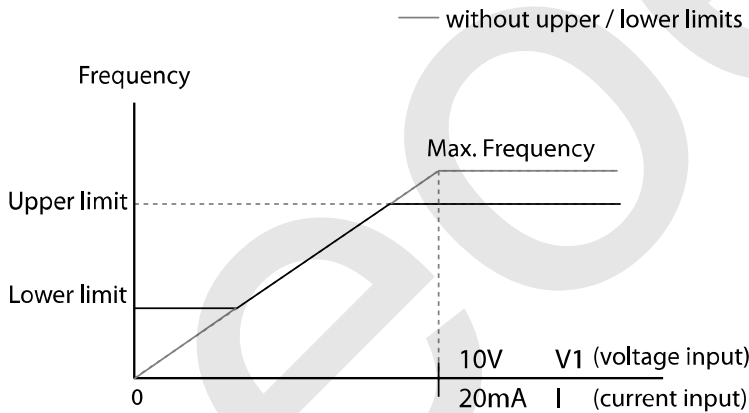

**⚠ Caution**

- When ADV-24 (Freq Limit) is set to "Yes," the frequency set at ADV-25 (Freq Limit Lo) is the minimum frequency (Low Freq). If ADV-24 (Freq Limit) is set to "No," the frequency set at DRV-19 (Start Freq) becomes the minimum frequency.
- When ADV-24 (Freq Limit) is set to "Yes," the frequency set at ADV-26 (Freq Limit Hi) is the maximum frequency (High Freq). If ADV-24 (Freq Limit) is set to "No," the frequency set at DRV-20 (Max Freq) becomes the maximum frequency.

### 7.18.3 Frequency Jump

Use frequency jump to avoid mechanical resonance frequencies. The inverter will avoid specific frequency ranges during acceleration and deceleration. Operation frequencies cannot be set within the preset frequency jump band.

When the operation frequency is increased while the frequency parameter setting value (voltage, current, RS-485 communication, keypad setting, etc.) is within a jump frequency band, the frequency will be maintained at the lower limit value of the frequency band. Then, the frequency will increase when the frequency parameter setting exceeds the range of frequencies used by the frequency jump band.

| Group | Code | Name                         | LCD Display | Parameter Setting | Setting Range                                  | Unit |
|-------|------|------------------------------|-------------|-------------------|--|------|
| ADV   | 27   | Frequency jump               | Jump Freq   | 0 --- No ---      | No/Yes   | -    |
|       | 28   | Jump frequency lower limit1  | Jump Lo 1   | 10.00             | 0.00–Jump frequency upper limit 1              | Hz   |
|       | 29   | Jump frequency upper limit1  | Jump Hi 1   | 15.00             | Jump frequency lower limit 1–Maximum frequency | Hz   |
|       | 30   | Jump frequency lower limit 2 | Jump Lo 2   | 20.00             | 0.00–Jump frequency upper limit 2              | Hz   |
|       | 31   | Jump frequency upper limit 2 | Jump Hi 2   | 25.00             | Jump frequency lower limit 2–Maximum frequency | Hz   |
|       | 32   | Jump frequency lower limit 3 | Jump Lo 3   | 30.00             | 0.00–Jump frequency upper limit 3              | Hz   |
|       | 33   | Jump frequency upper limit 3 | Jump Hi 3   | 35.00             | Jump frequency lower limit 3–Maximum frequency | Hz   |

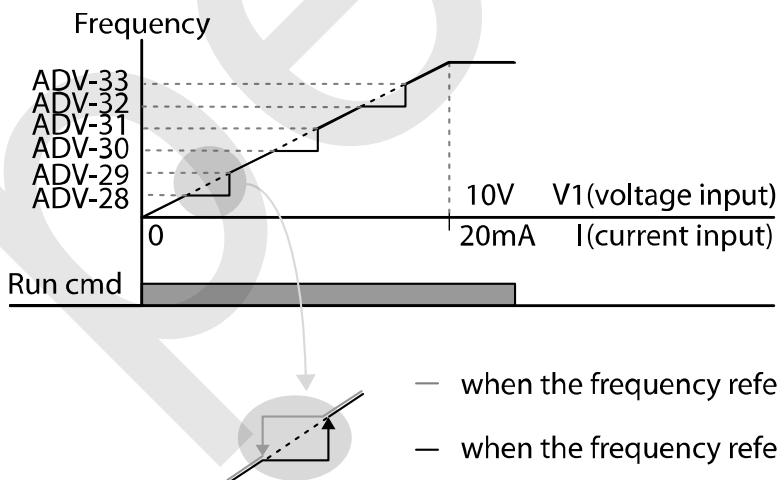

## 7.19 2<sup>nd</sup> Operation Mode Setting

Apply two types of operation modes and switch between them as required. For both the first and second command source, set the frequency after shifting operation commands to the multi-function input terminal. Mode switching can be used to stop remote control during an operation using the communication option and to switch the operation mode to operate via the local panel, or to operate the inverter from another remote control location.

Select one of the multi-function terminals from codes IN-65–75 and set the parameter value to “15 (2nd Source)”.

| Group | Code  | Name                           | LCD Display                                    | Parameter Setting |            | Unit |
|-------|-------|--------------------------------|--|-------------------|------------|------|
| DRV   | 06    | Command source                 | Cmd Source                                     | 1                 | Fx/Rx-1    | -    |
|       | 07    | Frequency reference source     | Freq Ref Src                                   | 2                 | V1         | -    |
|       | 08    | Torque reference source        | Trq Ref Src                                    | 0                 | Keypad-1   |      |
| BAS   | 04    | 2nd command source             | Cmd 2nd Src                                    | 0                 | Keypad     | -    |
|       | 05    | 2nd frequency reference source | Freq 2nd Src                                   | 0                 | KeyPad-1   | -    |
|       | 06    | 2nd torque reference source    | Trq 2 <sup>nd</sup> Src                        | 0                 | Keypad-1   |      |
| IN    | 65–75 | Px terminal configuration      | Px Define<br>(Px: P1–P8 [optional:<br>P9–P11]) | 15                | 2nd Source | -    |

### 2nd Operation Mode Setting Details

| Code                                      | Description   |
|---|---|
| BAS-04 Cmd 2nd Src<br>BAS-05 Freq 2nd Src | If signals are provided to the multi-function terminal set as the 2nd command source (2nd Source), the operation can be performed using the values set at BAS-04–05 instead of the values set at DRV-06 and DRV-07.<br>The 2nd command source settings cannot be changed while operating with the 1st command source (Main Source).   |
| BAS-06 Trq 2nd Src                        | If signals are provided to the multi-function terminal set as the 2nd command source (2nd Source), the operation can be performed using the torque reference set at BAS-06 instead of the value set at DRV-08.<br>Codes DRV-08 and BAS-06 are visible only when DRV-09 (Control mode) is set to “sensorless” or “vector” control mode, and DRV-10 (Torque control) is set to “Yes.” |

### ⚠ Caution

- When you set the multi-function terminal to the 2nd command source (2nd Source) and input the signal, the inverter’s operation state changes according to the operation frequency and the operation command configured for the 2nd command. Before shifting the input to the multi-function terminal,

ensure that the 2nd command is correctly set. An overvoltage fault trip may occur if the deceleration time is too short or the inertia of the load is too high.

- Depending on the parameter settings, the inverter may stop operating when you switch command modes.













## 7.20 Multi-function Input Terminal Control

Filter time constants and the type of multi-function input terminals can be configured to improve the response of the input terminals.

| Group | Code | Name                                     | LCD Display  | Parameter Setting | Setting Range | Unit |
|-------|------|--|--------------|-------------------|---------------|------|
| IN    | 85   | Multi-function input terminal On filter  | DI On Delay  | 0                 | 0–10000       | ms   |
|       | 86   | Multi-function input terminal Off filter | DI Off Delay | 0                 | 0–10000       | ms   |
|       | 87   | Multi-function input terminal selection  | DI NC/NO Sel | 0000 0000*        | -             | -    |
|       | 90   | Multi-function input terminal status     | DI Status    | 0000 0000*        | -             | -    |

\* From the last bit to the first, the bits are for multi-purpose inputs P1–P8 (the last bit is for input 1, and the first bit is for input 8).

### Multi-function Input Terminal Control Setting Details

| Code                                     | Description  |   |                                     |                                   |        |   |
|--|--|---|-------------------------------------|-----------------------------------|--------|---|
| IN-85 DI On Delay,<br>IN-86 DI Off Delay | When the terminal receives an On or Off input signal, it is recognized as an On or Off signal after the set delay time has elapsed.  |   |                                     |                                   |        |   |
| IN-87 DI NC/<br>NO Sel                   | Selects terminal contact types for each input terminal. The position of the dot corresponds to the segment that is on as shown in the table below. With the bottom segment on, it indicates that the terminal is configured as an A terminal (Normally Open) contact. With the top segment on, it indicates that the terminal is configured as a B terminal (Normally Closed) contact. Terminals are numbered P1–P8, from right to left. |   |                                     |                                   |        |   |
|  | <table border="1"> <thead> <tr> <th>Type</th> <th>B terminal status (Normally Closed)</th> <th>A terminal status (Normally Open)</th> </tr> </thead> <tbody> <tr> <td>Keypad</td> <td></td> <td></td> </tr> </tbody> </table>                                      | Type  | B terminal status (Normally Closed) | A terminal status (Normally Open) | Keypad |  |
| Type                                     | B terminal status (Normally Closed)  | A terminal status (Normally Open)   |                                     |                                   |        |   |
| Keypad                                   |   |  |                                     |                                   |        |   |
| IN-90 DI Status                          | Displays the configuration of each contact. When a segment is configured as an A terminal at DRV-87, the On condition is indicated by the top segment turning on. The Off condition is indicated when the bottom segment is turned on. When contacts are configured as B terminals, the segment dots behave conversely. Terminals are numbered P1–P8, from right to left.  |   |                                     |                                   |        |   |
|  | <table border="1"> <thead> <tr> <th>Type</th> <th>A terminal setting (On)</th> <th>A terminal setting (Off)</th> </tr> </thead> <tbody> <tr> <td>Keypad</td> <td></td> <td></td> </tr> </tbody> </table>   | Type  | A terminal setting (On)             | A terminal setting (Off)          | Keypad |  |
| Type                                     | A terminal setting (On)  | A terminal setting (Off)  |                                     |                                   |        |   |
| Keypad                                   |   |  |                                     |                                   |        |   |

## 7.21 Expanded I/O Control with an Optional I/O Expansion Module

You can install an I/O expansion module to add 3 digital input and 3 digital output (relay output) multi-function terminals to the iS7 inverter. The following table lists the function codes to control the expanded I/O functions.

| Group | Code | Name  | LCD Display | Parameter Setting |       | Unit |
|-------|------|---|-------------|-------------------|-------|------|
| IN    | 73   | Px terminal configuration (P9 terminal function)  | P9 Define   | 0                 | None  | -    |
|       | 74   | Px terminal configuration (P10 terminal function) | P10 Define  | 0                 | None  | -    |
|       | 75   | Px terminal configuration (P11 terminal function) | P11 Define  | 0                 | None  | -    |
| OUT   | 34   | Multi-function relay-3                            | Relay 3     | 2                 | FDT-2 | -    |
|       | 35   | Multi-function relay-4                            | Relay 4     | 3                 | FDT-3 | -    |
|       | 36   | Multi-function relay-5                            | Relay 5     | 4                 | FDT-4 | -    |

## 8 Learning Advanced Features

This chapter describes the advanced features of the iS7 inverter.

### 8.1 Operating with Auxiliary References

Frequency references can be configured with various calculated conditions that use the main and auxiliary frequency references simultaneously. The main frequency reference is used as the operating frequency, while auxiliary references are used to modify and fine-tune the main reference.

| Group | Code  | Name   | LCD Display   | Parameter Setting |             | Setting Range | Unit |
|-------|-------|--|---------------|-------------------|-------------|---------------|------|
| DRV   | 07    | Frequency reference source                     | Freq Ref Src  | 0                 | Keypad-1    | 0–9           | -    |
| BAS   | 01    | Auxiliary frequency reference source           | Aux Ref Src   | 1                 | V1          | 0–5           | -    |
|       | 02    | Auxiliary frequency reference calculation type | Aux Calc Type | 0                 | M+(G*A)     | 0–7           | -    |
|       | 03    | Auxiliary frequency reference gain             | Aux Ref Gain  | -                 | 0.00        | -200.0–200.0  | %    |
| IN    | 65–75 | Px terminal configuration                      | Px Define     | 36                | dis Aux Ref | 0–48          | -    |

\* Codes IN-01–16 must be set to the default values, and IN-06 (V1 Polarity), set to “1 (Bipolar)”.

The table above lists the available calculated conditions for the main and auxiliary frequency references. Refer to the table to see how the calculations apply to an example where the DRV-07 Frq Src code has been set to “0 (Keypad-1)”, and the inverter is operating at a main reference frequency of 30.00 Hz. Signals at -10 to +10 V are received at terminal V1, with the reference gain set at 5%. In this example, the resulting frequency reference is fine-tuned within the range of 27.00–33.00 Hz\* (+/- 5% of 60 Hz).

#### Auxiliary Reference Setting Details

| Code               | Description  |               |             |   |      |   |    |   |    |   |    |
|--------------------|--|---------------|-------------|---|------|---|----|---|----|---|----|
| BAS-01 Aux Ref Src | Sets the input type to be used for the auxiliary frequency reference.  |               |             |   |      |   |    |   |    |   |    |
|                    | <table border="1"> <thead> <tr> <th>Configuration</th> <th>Description</th> </tr> </thead> <tbody> <tr> <td>0</td> <td>None</td> </tr> <tr> <td>1</td> <td>V1</td> </tr> <tr> <td>2</td> <td>I1</td> </tr> <tr> <td>3</td> <td>V2</td> </tr> </tbody> </table> | Configuration | Description | 0 | None | 1 | V1 | 2 | I1 | 3 | V2 |
|                    | Configuration  | Description   |             |   |      |   |    |   |    |   |    |
|                    | 0  | None          |             |   |      |   |    |   |    |   |    |
|                    | 1  | V1            |             |   |      |   |    |   |    |   |    |
| 2                  | I1   |               |             |   |      |   |    |   |    |   |    |
| 3                  | V2   |               |             |   |      |   |    |   |    |   |    |
|                    | Auxiliary frequency reference is disabled.   |               |             |   |      |   |    |   |    |   |    |
|                    | Sets the V1 (voltage) terminal at the control terminal block as the source of the auxiliary frequency reference.   |               |             |   |      |   |    |   |    |   |    |
|                    | Sets the I1 (current) terminal at the control terminal block as the source of the auxiliary frequency reference.   |               |             |   |      |   |    |   |    |   |    |
|                    | Sets the V2 (voltage) terminal at the optional I/O expansion module as the source of the auxiliary frequency reference.  |               |             |   |      |   |    |   |    |   |    |

| Code  | Description   |  |   |
|---|---|--|---|
|   | 4   | I2                                     | Sets the I2 (current) terminal at the optional I/O expansion module as the source of the auxiliary frequency reference. |
|   | 5   | Pulse                                  | Sets the pulse input terminal at the optional encoder module as the source of the auxiliary frequency reference.        |
| BAS-02<br>Aux Calc Type   | Sets the auxiliary reference gain with BAS-03 (Aux Ref Gain) to configure the auxiliary reference and set BAS-02 to decide the percentage to be reflected when calculating the main reference. Note that items 4–7 below may result in either plus (+) or minus (-) references (forward or reverse operation) even when unipolar analog inputs are used.* |  |   |
|   |   | Configuration                          | Formula for frequency reference   |
|   | 0   | $M+(G \cdot A)$                        | Main reference + (BAS-03 x BAS-01 x IN-01)  |
|   | 1   | $M \cdot (G \cdot A)$                  | Main reference x (BAS-03 x BAS-01)  |
|   | 2   | $M/(G \cdot A)$                        | Main reference / (BAS-03 x BAS-01)  |
|   | 3   | $M + \{M \cdot (G \cdot A)\}$          | Main reference + (Main reference x [BAS-03 x BAS-01])   |
|   | 4   | $M + G \cdot 2 \cdot (A - 50)$         | Main reference + BAS-03 x 2 x (BAS-01-50) x IN-01   |
|   | 5   | $M \cdot \{G \cdot 2 \cdot (A - 50)\}$ | Main reference x (BAS-03 x 2 x [BAS-01-50])   |
|   | 6   | $M / \{G \cdot 2 \cdot (A - 50)\}$     | Main reference / (BAS-03 x 2 x [BAS-01-50])   |
|   | 7   | $M + M \cdot G \cdot 2 \cdot (A - 50)$ | Main reference + Main reference x BAS-03 x 2 x (BAS-01-50)  |
| M: Main frequency reference (Hz or rpm)<br>G: Auxiliary reference gain (%)<br>A: Auxiliary frequency reference (Hz or rpm) or gain (%)                          |   |  |   |
| <b>Note</b><br>When the maximum frequency value is high, output frequency deviation may occur due to analog input variation and deviations in the calculations. |   |  |   |
| BAS-03 Aux Ref Gain   | Adjusts the size of the input (BAS-01 Aux Ref Src) configured for the auxiliary frequency.  |  |   |
| IN-65–75 Px Define  | Set one of the multi-function input terminals to “40 (dis Aux Ref)” and turn it on to disable the auxiliary frequency reference. The inverter will operate using the main frequency reference only.   |  |   |

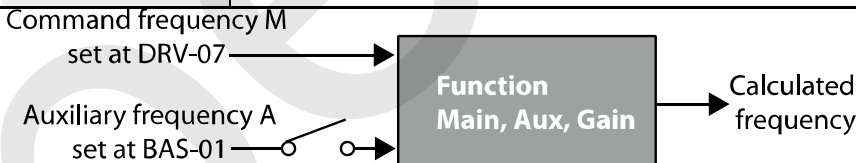

The auxiliary command frequency is turned off when the terminal input (Px) set to “40 (dis Aux Ref)” is on.

### Auxiliary Reference Operation Ex #1

#### Keypad Frequency Setting is Main Frequency, and V1 Analog Voltage is Auxiliary Frequency

- Main frequency (DRV-07): Keypad (operation frequency 30 Hz)
- Maximum frequency setting (DRV-20): 400 Hz
- Auxiliary frequency setting (BAS-01): V1 [Display by percentage (%) or auxiliary frequency (Hz) depending on the operation setting condition]
- Auxiliary reference gain setting (BAS-03): 50%
- IN-01–32: Factory default

Example: An input voltage of 6 V is supplied to V1, and the frequency corresponding to 10 V is 60 Hz. The table below shows the auxiliary frequency A as 36 Hz [=60 Hz X (6 V/10 V)] or 60% [= 100% X (6 V/10 V)].

| Setting *  | Calculating final command frequency**   |
|--|---|
| 0 $M[\text{Hz}] + (G[\%] \cdot A[\text{Hz}])$                              | $30 \text{ Hz}(M) + (50\%(G) \times 36 \text{ Hz}(A)) = 48 \text{ Hz}$                                |
| 1 $M[\text{Hz}] \cdot (G[\%] \cdot A[\%])$                                 | $30 \text{ Hz}(M) \times (50\%(G) \times 60\%(A)) = 9 \text{ Hz}$                                     |
| 2 $M[\text{Hz}] / (G[\%] \cdot A[\%])$                                     | $30 \text{ Hz}(M) / (50\%(G) \times 60\%(A)) = 100 \text{ Hz}$  |
| 3 $M[\text{Hz}] + \{M[\text{Hz}] \cdot (G[\%] \cdot A[\%])\}$              | $30 \text{ Hz}(M) + \{30[\text{Hz}] \times (50\%(G) \times 60\%(A))\} = 39 \text{ Hz}$                |
| 4 $M[\text{Hz}] + G[\%] \cdot 2 \cdot (A[\%] - 50[\%])[\text{Hz}]$         | $30 \text{ Hz}(M) + 50\%(G) \times 2 \times (60\%(A) - 50\%) \times 60 \text{ Hz} = 36 \text{ Hz}$    |
| 5 $M[\text{Hz}] \cdot \{G[\%] \cdot 2 \cdot (A[\%] - 50[\%])\}$            | $30 \text{ Hz}(M) \times \{50\%(G) \times 2 \times (60\%(A) - 50\%)\} = 3 \text{ Hz}$                 |
| 6 $M[\text{Hz}] / \{G[\%] \cdot 2 \cdot (A[\%] - 50[\%])\}$                | $30 \text{ Hz}(M) / \{50\%(G) \times 2 \times (60\% - 50\%)\} = 300 \text{ Hz}$                       |
| 7 $M[\text{Hz}] + M[\text{Hz}] \cdot G[\%] \cdot 2 \cdot (A[\%] - 50[\%])$ | $30 \text{ Hz}(M) + 30 \text{ Hz}(M) \times 50\%(G) \times 2 \times (60\%(A) - 50\%) = 33 \text{ Hz}$ |

\* M: Main frequency reference (Hz or rpm)/G: Auxiliary reference gain (%)/A: Auxiliary frequency reference (Hz or rpm) or gain (%).

\*\* If the frequency setting is changed to rpm, it is converted to rpm instead of Hz.

Auxiliary Reference Operation Ex #2

**The Keypad Frequency Setting is the Main Frequency, and I2 Analog Voltage is the Auxiliary Frequency**

- Main frequency (DRV-07): Keypad (Operation frequency 30 Hz)
- Maximum frequency setting (BAS-20): 400 Hz
- Auxiliary frequency setting (BAS-01): I1 [Display by percentage (%) or auxiliary frequency (Hz) depending on the operation setting condition]
- Auxiliary reference gain setting (BAS-03): 50%
- IN-01–32: Factory default

Example: An input current of 10.4 mA is applied to I1, with the frequency corresponding to 20 mA of 60 Hz. The table below shows auxiliary frequency A as 24 Hz [=60[Hz] X {(10.4[mA]-4[mA])/(20[mA] - 4[mA])}] or 40% [=100[%] X {(10.4[mA] - 4[mA])/(20[mA] - 4[mA])}].

| Setting*                        | Calculating final command frequency**             |
|---------------------------------|---|
| 0 M[Hz]+(G[%]*A[Hz])            | 30 Hz(M)+(50%(G)x24 Hz(A))=42 Hz                  |
| 1 M[Hz]*(G[%]*A[%])             | 30 Hz(M)x(50%(G)x40%(A))=6 Hz                     |
| 2 M[Hz]/(G[%]*A[%])             | 30 Hz(M)/(50%(G)x40%(A))=150 Hz                   |
| 3 M[Hz]+{M[Hz]*(G[%]*A[%])}     | 30 Hz(M)+{30[Hz]x(50%(G)x40%(A))}=36 Hz           |
| 4 M[Hz]+G[%]*2*(A[%]-50%)[Hz]   | 30 Hz(M)+50%(G)x2x(40%(A)-50%)x60 Hz=24 Hz        |
| 5 M[Hz]*(G[%]*2*(A[%]-50%))     | 30 Hz(M)x{50%(G)x2x(40%(A)-50%)}=-3 Hz (Reverse ) |
| 6 M[Hz]/{G[%]*2*(A[%]-50%)}     | 30 Hz(M)/{50%(G)x2x(60%-40%)}=-300 Hz (Reverse )  |
| 7 M[Hz]+M[Hz]*G[%]*2*(A[%]-50%) | 30 Hz(M)+30 Hz(M)x50%(G)x2x (40%(A)-50%)=27 Hz    |

\* M: Main frequency reference (Hz or rpm)/G: Auxiliary reference gain (%)/A: Auxiliary frequency reference Hz or rpm) or gain (%).

\*\* If the frequency setting is changed to rpm, it is converted to rpm instead of Hz.

## Auxiliary Reference Operation Ex #3

### V1 is the Main Frequency, and I1 is the Auxiliary Frequency

- Main frequency (DRV-07): V1 (frequency command setting to 5 V and is set to 30 Hz)
- Maximum frequency setting (DRV-20): 400 Hz
- Auxiliary frequency (BAS-01): I1 [Display by percentage (%) or auxiliary frequency (Hz) depending on the operation setting condition]
- Auxiliary reference gain (BAS-03): 50%
- IN-01–32: Factory default

Example: An input current of 10.4 mA is applied to I1, with the frequency corresponding to 20 mA of 60 Hz. The table below shows auxiliary frequency A as 24 Hz [=60[Hz]x{(10.4[mA]-4[mA])/(20[mA]-4[mA])}] or 40% [=100[%] x {(10.4[mA] - 4[mA]) / (20 [mA] - 4[mA])}].

| Setting*                        | Calculating final command frequency**           |
|---------------------------------|---|
| 0 M[Hz]+(G[%]*A[Hz])            | 30 Hz(M)+(50%(G)x24 Hz(A))=42 Hz                |
| 1 M[Hz]*(G[%]*A[%])             | 30 Hz(M)x(50%(G)x40%(A))=6 Hz                   |
| 2 M[Hz]/(G[%]*A[%])             | 30 Hz(M)/(50%(G)x40%(A))=150 Hz                 |
| 3 M[Hz]+{M[Hz]*(G[%]*A[%])}     | 30 Hz(M)+{30[Hz]x(50%(G)x40%(A))}=36 Hz         |
| 4 M[Hz]+G[%]*2*(A[%]-50%)[Hz]   | 30 Hz(M)+50%(G)x2x(40%(A)-50%)x60 Hz=24 Hz      |
| 5 M[Hz]*{G[%]*2*(A[%]-50%)}     | 30 Hz(M)x{50%(G)x2x(40%(A)-50%)=-3 Hz (Reverse) |
| 6 M[Hz]/{G[%]*2*(A[%]-50%)}     | 30 Hz(M)/{50%(G)x2x(60%-40%)=-300 Hz(Reverse)   |
| 7 M[Hz]+M[Hz]*G[%]*2*(A[%]-50%) | 30 Hz(M)+30 Hz(M)x50%(G)x2x(40%(A)-50%)=27 Hz   |

\* M: Main frequency reference (Hz or rpm)/G: Auxiliary reference gain (%)/A: Auxiliary frequency reference (Hz or rpm) or gain (%).

\*\*If the frequency setting is changed to rpm, it is converted to rpm instead of Hz.

### Note

When the maximum frequency value is high, output frequency deviation may occur due to analog input variation and deviations in the calculations.

## 8.2 Jog Operation

The jog operation allows for temporary control of the inverter. You can enter a jog operation command using the multi-function terminals.

The jog operation is the second-highest priority operation, after the dwell operation. If a jog operation is requested while operating the multi-step, up-down, or 3-wire operation modes, the jog operation overrides all other operation modes.

### 8.2.1 Jog Operation 1-Forward Jog via Multi-function Terminal

The jog operation is available using the multi-function terminal input. To start a forward jog operation, an Fx operation command must be entered. The table below lists parameter settings for a forward jog operation using the multi-function terminal input.

| Group | Code  | Name                            | LCD Display                             | Parameter Setting |     | Setting Range | Unit |
|-------|-------|---------------------------------|---|-------------------|-----|---------------|------|
| DRV   | 11    | Jog frequency                   | JOG Frequency                           | 10.00             |     | 0.5– Max Freq | Hz   |
|       | 12    | Jog operation acceleration time | JOG Acc Time                            | 20.00             |     | 0.00–600.00   | sec  |
|       | 13    | Jog operation deceleration time | JOG Dec Time                            | 30.00             |     | 0.00–600.00   | sec  |
| IN    | 65–75 | Px terminal configuration       | Px Define(Px: P1–P8 [optional: P9–P11]) | 6                 | JOG | -             | -    |

#### Forward Jog Details

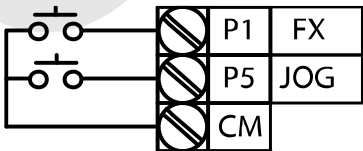
| Code                 | Description  |
|----------------------|--|
| IN-65–75 Px Define   | <p>Select an input terminal from IN-65–75 (P1–P8 [optional: P9–P11]) and set it to “6 (Jog)”.</p>  <p>[Terminal settings for jog operation using the P5 terminal]</p> |
| DRV-11 JOG Frequency | Sets the operation frequency.  |
| DRV-12 JOG Acc Time  | Sets the acceleration speed for a jog operation.   |
| DRV-13 JOG Dec Time  | Sets the deceleration speed for a jog operation.   |

If a signal is entered at the jog terminal while an Fx operation command is on, the operation



frequency changes to the jog frequency and the jog operation begins.

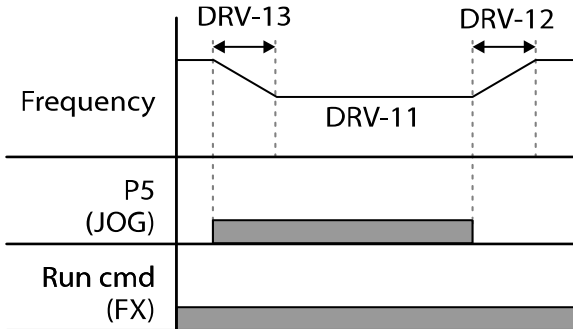

## 8.2.2 Jog Operation 2-Forward/Reverse Jog via Multi-function Terminal

For jog operation 1, an operation command must be entered to start an operation, but while using jog operation 2, a terminal that is set for a forward or reverse jog also starts an operation.

The priorities for the frequency, acc/dec time and terminal block input during operation in relation to other operating modes (Dwell, 3-wire, up/down, etc.) are identical to jog operation 1. If a different operation command is entered during a jog operation, it is ignored and the operation maintains the jog frequency.

| Group | Code  | Name                            | LCD Display                              | Parameter setting |         | Setting Range | Unit |
|-------|-------|---------------------------------|--|-------------------|---------|---------------|------|
| DRV   | 11    | Jog frequency                   | JOG Frequency                            | 10.00             |         | 0.5–Max Freq  | Hz   |
|       | 12    | Jog operation acceleration time | JOG Acc Time                             | 20.00             |         | 0.00–600.00   | sec  |
|       | 13    | Operation deceleration time     | JOG Dec Time                             | 30.00             |         | 0.00–600.00   | sec  |
| IN    | 65–75 | Px terminal configuration       | Px Define (Px: P1–P8 [optional: P9–P11]) | 46                | FWD JOG | -             | -    |
|       |       |                                 |  | 47                | REV JOG |               |      |

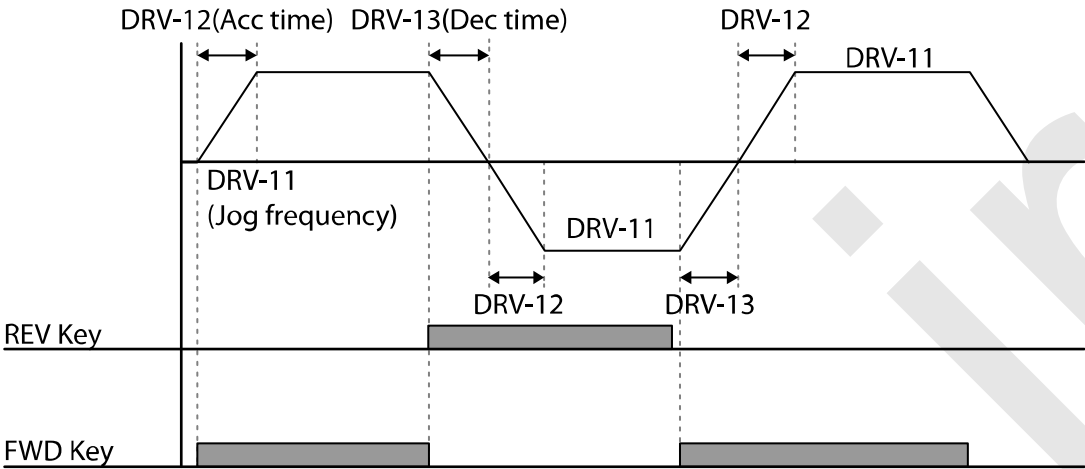

### 8.2.3 Jog Operation via Keypad Input

The jog operation is available using the keypad input as well.

The priorities for the frequency, acc/dec time, and terminal block input during an operation in relation to other operating modes (Dwell, 3-wire, up/down, etc.) are identical to jog operations using the terminal input.

| Group | Code | Name                            | LCD Display   | Parameter setting | Setting Range | Unit |
|-------|------|---------------------------------|---------------|-------------------|---------------|------|
| DRV   | 11   | Jog frequency                   | JOG Frequency | 10.00             | 0.5–Max Freq  | Hz   |
|       | 12   | Jog operation acceleration time | JOG Acc Time  | 20.00             | 0.00–600.00   | sec  |
|       | 13   | Operation deceleration time     | JOG Dec Time  | 30.00             | 0.00–600.00   | sec  |

The table below lists parameter settings for a forward jog operation using the keypad input.

| MODE | Group | Code | LCD Display   | Parameter Setting | Setting Range | Unit |
|------|-------|------|---------------|-------------------|---------------|------|
| CNF  | -     | 42   | Multi-Key Sel | 1   JOG Key       | -             | -    |
| PAR  | DRV   | 06   | Cmd Source    | 0   Keypad        | 0–5           | sec  |

After setting CNF-42 to “1 (JOG Key)” and DRV-06 (in PAR mode) to “0 (Keypad)”, you can start the jog operation using the keypad by pressing the [MULTI] key on the keypad.

When you press the [MULTI] key, “J” is displayed on the keypad indicating that a jog operation via the keypad is available. Press and hold the [FWD] or [REV] key to perform forward or reverse jog operations. Jog operations stop when you lift your finger from the [FWD] or [REV] key on the keypad.

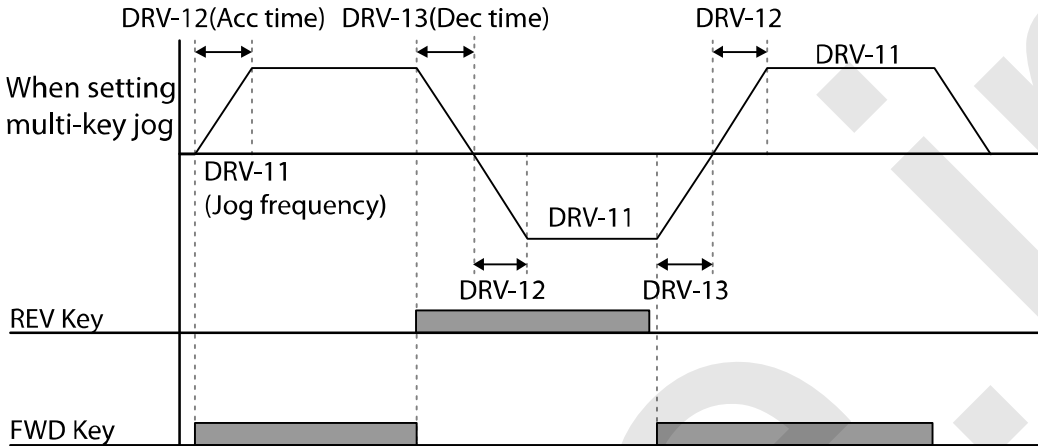

### 8.3 Up/down Operation

The acc/dec time can be controlled via the input at the multi-function terminal block. The up-down operation can be applied easily to a system that uses the upper-lower limit switch signals (such as those of a flow meter) for acc/dec commands.

| Group | Code  | Name                             | LCD Display                              | Parameter Setting |            | Setting Range                                 | Unit |
|-------|-------|----------------------------------|--|-------------------|------------|---|------|
| ADV   | 65    | Up/down operation frequency save | U/D Save Mode                            | 1                 | Yes        | 0–1   | -    |
|       | 85    | Up/down mode Sel                 | U/D Mode Sel                             | 0                 | U/D Normal | 0:U/D Normal<br>1:U/D Step<br>2:U/D Step+Norm | -    |
|       | 86    | Up/down Step frequency           | U/D Step Freq                            | -                 | 0          | 0-maximum frequency                           | Hz   |
| IN    | 65–75 | Px terminal configuration        | Px Define (Px: P1–P8 [optional: P9–P11]) | 17                | Up         | 0–51  | -    |
|       |       |                                  |  | 18                | Down       |   |      |
|       |       |                                  |  | 19                | U/D Save   |   |      |
|       |       |                                  |  | 20                | U/D Clear  |   |      |

Up/down Operation Setting Details

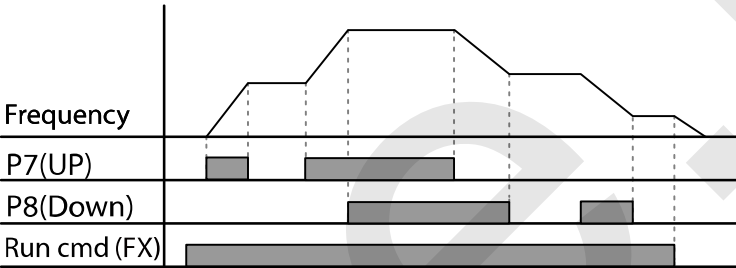
| Code   | Description   |  |  |                 |   |   |          |   |   |          |   |   |          |   |   |          |
|--|---|--|--|-----------------|---|---|----------|---|---|----------|---|---|----------|---|---|----------|
| IN-65-75 Px Define                             | <p>Select two terminals for up/down operation and set them to “19 (Up)” and “20 (Down)”, respectively. With the operation command input, acceleration begins when the Up terminal signal is on. Acceleration stops and constant speed operation begins when the signal is off.</p> <p>During operation, deceleration begins when the Down signal is on. Deceleration stops and a constant speed operation begins when both the Up and Down signals are entered at the same time.</p>  <p>The diagram illustrates the relationship between the Run command (FX) and the resulting frequency profile. When the Run cmd (FX) signal is active, the frequency begins to rise (acceleration). Once the P7(UP) signal is active, the frequency reaches a constant level (constant speed). When the P8(Down) signal becomes active, the frequency begins to fall (deceleration). The frequency returns to zero when the Run cmd (FX) signal is deactivated.</p>  |  |  |                 |   |   |          |   |   |          |   |   |          |   |   |          |
| ADV-65 U/D Save Mode                           | <p>During a constant speed operation, the operating frequency is saved automatically under the following conditions: The operation command (Fx or Rx) is off, a fault trip occurs, or the power is off.</p> <p>You can also save the up/down operation frequency while the inverter is operated at a constant speed by setting one of the multi-function terminals (IN-65-75) to “19 (U/D Save)”, or by setting ADV-65 to “1 (Yes)”.</p> <p>If the up/down frequency saving function is enabled for the terminal and keypad inputs, the operation frequency will be saved as described in the following table:</p> <table border="1" data-bbox="388 1174 1243 1387"> <thead> <tr> <th>Save by keypad input (ADV-65) set to “1 (Yes)”</th> <th>Save by keypad input (IN-65-75) set to “19 (U/D Save)”</th> <th>U/D Save Result</th> </tr> </thead> <tbody> <tr> <td>X</td> <td>X</td> <td><b>X</b></td> </tr> <tr> <td>O</td> <td>X</td> <td><b>O</b></td> </tr> <tr> <td>X</td> <td>O</td> <td><b>O</b></td> </tr> <tr> <td>O</td> <td>O</td> <td><b>O</b></td> </tr> </tbody> </table> | Save by keypad input (ADV-65) set to “1 (Yes)” | Save by keypad input (IN-65-75) set to “19 (U/D Save)” | U/D Save Result | X | X | <b>X</b> | O | X | <b>O</b> | X | O | <b>O</b> | O | O | <b>O</b> |
| Save by keypad input (ADV-65) set to “1 (Yes)” | Save by keypad input (IN-65-75) set to “19 (U/D Save)”  | U/D Save Result                                |  |                 |   |   |          |   |   |          |   |   |          |   |   |          |
| X  | X   | <b>X</b>                                       |  |                 |   |   |          |   |   |          |   |   |          |   |   |          |
| O  | X   | <b>O</b>                                       |  |                 |   |   |          |   |   |          |   |   |          |   |   |          |
| X  | O   | <b>O</b>                                       |  |                 |   |   |          |   |   |          |   |   |          |   |   |          |
| O  | O   | <b>O</b>                                       |  |                 |   |   |          |   |   |          |   |   |          |   |   |          |

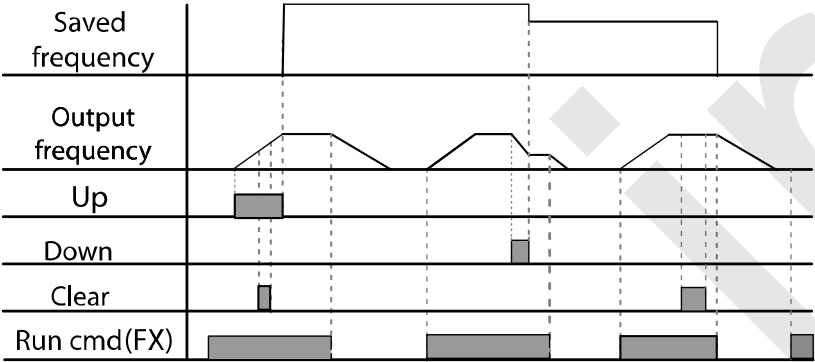
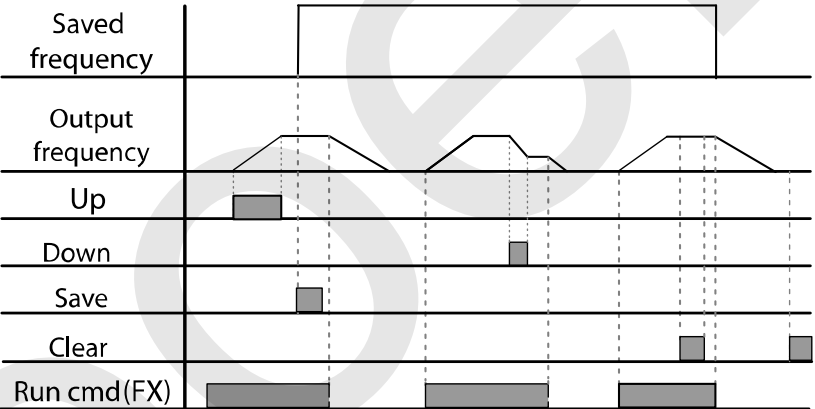
| Code                       | Description   |               |             |                     |   |                   |  |
|----------------------------|---|---------------|-------------|---------------------|---|-------------------|--|
|                            | <p>ADV-65 U/D Save Mode: Yes</p>  <p>ADV-65 U/D Save Mode: No</p>  <p>When the operation command is turned on again, or when the inverter regains the power source or resumes to a normal operation from a fault trip, it resumes operation at the saved frequency.</p> <p>To delete the saved frequency, use the multi-function terminal block. Set one of the multi-function terminals to “20 (U/D Clear)” and apply signals to it during a constant speed operation. The saved frequency and the up/down operation configuration will be deleted.</p> |               |             |                     |   |                   |  |
| <p>ADV-85 U/D Mode Sel</p> | <table border="1"> <thead> <tr> <th data-bbox="388 1450 655 1508">Configuration</th> <th data-bbox="655 1450 1244 1508">Description</th> </tr> </thead> <tbody> <tr> <td data-bbox="388 1508 655 1595"> <p>0 U/D Normal</p> </td> <td data-bbox="655 1508 1244 1595"> <p>Targeted Frequency increase or decrease based on Max/Min Frequency</p> </td> </tr> <tr> <td data-bbox="388 1595 655 1713"> <p>1 U/D Step</p> </td> <td data-bbox="655 1595 1244 1713"> <p>According to Edge input of up/down port, Frequency will be increase or decrease as much as ADV-86 setting date.</p> </td> </tr> </tbody> </table>  | Configuration | Description | <p>0 U/D Normal</p> | <p>Targeted Frequency increase or decrease based on Max/Min Frequency</p> | <p>1 U/D Step</p> | <p>According to Edge input of up/down port, Frequency will be increase or decrease as much as ADV-86 setting date.</p> |
| Configuration              | Description   |               |             |                     |   |                   |  |
| <p>0 U/D Normal</p>        | <p>Targeted Frequency increase or decrease based on Max/Min Frequency</p>   |               |             |                     |   |                   |  |
| <p>1 U/D Step</p>          | <p>According to Edge input of up/down port, Frequency will be increase or decrease as much as ADV-86 setting date.</p>  |               |             |                     |   |                   |  |

| Code  | Description   |   |
|---|---------------|---|
| 2   | U/D Step+Norm | Frequency that will be set by Edge input. |
| 1 : U/D STEP  |               |   |
| <p>Timing diagram for U/D STEP mode. The diagram shows four signals: Output Frequency, Up, Down, and FX. The Output Frequency signal is a trapezoidal wave that ramps up and then ramps down. The Up signal has two pulses, each 3 seconds wide, corresponding to the rising edges of the frequency. The Down signal has two pulses, each 3 seconds wide, corresponding to the falling edges of the frequency. The FX signal is a single long pulse that is active during the entire duration of the frequency change.</p>      |               |   |
| 2 : U/D STEP+Norm   |               |   |
| <p>Timing diagram for U/D STEP+Norm mode. The diagram shows four signals: Output Frequency, Up, Down, and FX. The Output Frequency signal is a trapezoidal wave that ramps up and then ramps down. The Up signal has two pulses, each 3 seconds wide, corresponding to the rising edges of the frequency. The Down signal has two pulses, each 3 seconds wide, corresponding to the falling edges of the frequency. The FX signal is a single long pulse that is active during the entire duration of the frequency change.</p> |               |   |

## 8.4 3-Wire Operation

The 3-wire operation latches the signal input (the signal stays on after the button is released), and is used when operating the inverter with a push button.

| Group | Code  | Name                      | LCD Display                             | Parameter Setting |           | Setting Range | Unit |
|-------|-------|---------------------------|---|-------------------|-----------|---------------|------|
| DRV   | 06    | Command source            | Cmd Source                              | 1                 | Fx/Rx - 1 | 0-5           | -    |
| IN    | 65-75 | Px terminal configuration | Px Define(Px: P1-P8 [optional: P9-P11]) | 14                | 3-Wire    | 0-51          | -    |

To enable the 3-wire operation, the following circuit sequence is necessary. The minimum input time ( $t$ ) for 3-wire operation is 1 ms, and the operation stops when both the forward and reverse operation commands are entered at the same time.

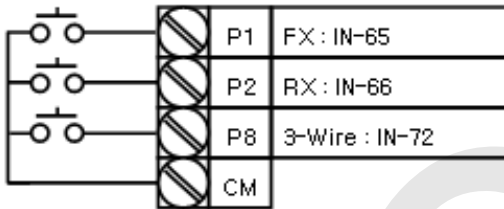

[Terminal connections for 3-wire operation]

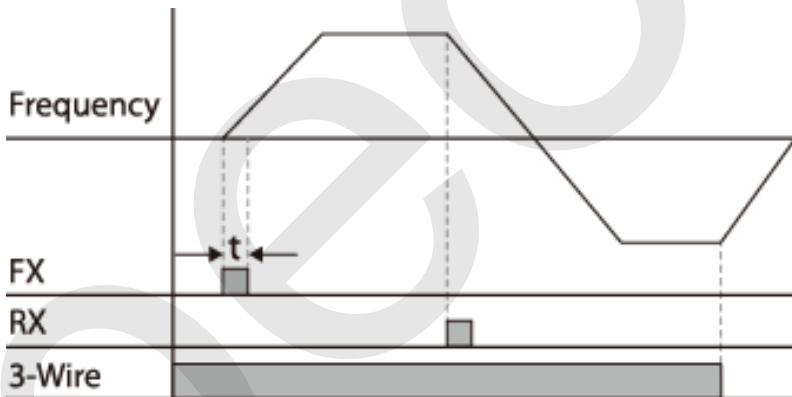

[3-wire operation]

## 8.5 Safe Operation Mode

When the multi-function terminals are configured to operate in Safe mode, operation commands can be entered in Safe mode only. Safe mode is used to safely control the inverter through the multi-function terminals.

| Group | Code  | Name                             | LCD Display                             | Parameter Setting |              | Setting Range                | Unit |
|-------|-------|----------------------------------|---|-------------------|--------------|------------------------------|------|
| ADV   | 70    | Safe operation selection         | Run En Mode                             | 1                 | DI Dependent | Always Enable / DI Dependent | -    |
|       | 71    | Safe operation stop mode         | Run Dis Stop                            | 0                 | Free-Run     | 0-2                          | -    |
|       | 72    | Safe operation deceleration time | Q-Stop Time                             | 5.0               |              | 0.0-600.0                    | sec  |
| IN    | 65-75 | Px terminal configuration        | Px Define(Px: P1-P8 [optional: P9-P11]) | 13                | RUN Enable   | 0-51                         | -    |

### Safe Operation Mode Setting Details

| Code                | Description  |         |          |                 |   |                |  |                 |   |
|---------------------|--|---------|----------|-----------------|---|----------------|--|-----------------|---|
| IN-65-75 Px Define  | From the multi-function terminals, select a terminal to operate in Safe mode and set it to "13 (RUN Enable)".  |         |          |                 |   |                |  |                 |   |
| ADV-70 Run En Mode  | <table border="1"> <thead> <tr> <th>Setting</th> <th>Function</th> </tr> </thead> <tbody> <tr> <td>0 Always Enable</td> <td>Safe operation mode is deactivated.</td> </tr> <tr> <td>1 DI Dependent</td> <td>Recognizes the operation command from a multi-function input terminal.</td> </tr> </tbody> </table>  | Setting | Function | 0 Always Enable | Safe operation mode is deactivated.                                 | 1 DI Dependent | Recognizes the operation command from a multi-function input terminal.   |                 |   |
| Setting             | Function   |         |          |                 |   |                |  |                 |   |
| 0 Always Enable     | Safe operation mode is deactivated.  |         |          |                 |   |                |  |                 |   |
| 1 DI Dependent      | Recognizes the operation command from a multi-function input terminal.   |         |          |                 |   |                |  |                 |   |
| ADV-71 Run Dis Stop | <p>Set the operation of the inverter when the multi-function input terminal configured for Safe mode is off.<br/>When the Safe mode signal is given, the inverter decelerates according to the settings at the Q-Stop time. The inverter decelerates and stops according to the deceleration time (Dec Time) settings if the run command is off.</p> <table border="1"> <thead> <tr> <th>Setting</th> <th>Function</th> </tr> </thead> <tbody> <tr> <td>1 Free-Run</td> <td>Blocks the inverter output when the multi-function terminal is off.</td> </tr> <tr> <td>2 Q-Stop</td> <td>The deceleration time (Q-Stop Time) used in Safe mode. It stops after deceleration and then the operation can resume only when the operation command is entered again. The operation will not begin if only the multi-function terminal is on.</td> </tr> <tr> <td>3 Q-Stop Resume</td> <td>The inverter decelerates to the deceleration time (Q-Stop Time) in Safe operation mode. It stops after deceleration. Then, if the multi-function terminal is on, the operation resumes as soon as the operation</td> </tr> </tbody> </table> | Setting | Function | 1 Free-Run      | Blocks the inverter output when the multi-function terminal is off. | 2 Q-Stop       | The deceleration time (Q-Stop Time) used in Safe mode. It stops after deceleration and then the operation can resume only when the operation command is entered again. The operation will not begin if only the multi-function terminal is on. | 3 Q-Stop Resume | The inverter decelerates to the deceleration time (Q-Stop Time) in Safe operation mode. It stops after deceleration. Then, if the multi-function terminal is on, the operation resumes as soon as the operation |
| Setting             | Function   |         |          |                 |   |                |  |                 |   |
| 1 Free-Run          | Blocks the inverter output when the multi-function terminal is off.  |         |          |                 |   |                |  |                 |   |
| 2 Q-Stop            | The deceleration time (Q-Stop Time) used in Safe mode. It stops after deceleration and then the operation can resume only when the operation command is entered again. The operation will not begin if only the multi-function terminal is on.   |         |          |                 |   |                |  |                 |   |
| 3 Q-Stop Resume     | The inverter decelerates to the deceleration time (Q-Stop Time) in Safe operation mode. It stops after deceleration. Then, if the multi-function terminal is on, the operation resumes as soon as the operation  |         |          |                 |   |                |  |                 |   |



| Code               | Description   |
|--------------------|---|
|                    | command is entered.   |
| ADV-72 Q-Stop Time | Set the deceleration time when ADV-71 (Run Dis Stop) is set to "1 (Q-Stop)" or "2 (Q-Stop Resume)". |

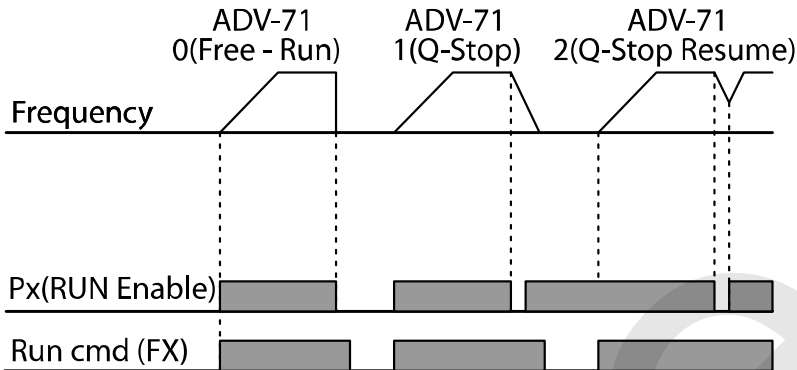

## 8.6 Dwell Operation

When DRV-09 (Control mode) is set to "0 (V/F mode)", a dwell operation may be used to maintain torque during inverter application, such as when enough torque is required before releasing mechanical brakes on lift-type loads. A dwell operation is based on the acc/dec dwell frequency and the dwell time set by the user. The following conditions also affect dwell operations.

- **Acceleration Dwell Operation:** When an operation command is given, acceleration continues until the acceleration dwell frequency and constant speed is reached within the acceleration dwell operation time (Acc Dwell Time). After the Acc Dwell Time has passed, acceleration is carried out based on the set acceleration time and operation speed.
- **Deceleration Dwell Operation:** When a stop command is given, deceleration continues until the deceleration dwell frequency and constant speed are reached within the deceleration dwell operation time (Dec Dwell Freq). After the set time has passed, deceleration is carried out based on the set deceleration time, and then the operation stops.

| Group | Code | Name                                | LCD Display    | Parameter Setting | Setting Range                       | Unit |
|-------|------|-------------------------------------|----------------|-------------------|-------------------------------------|------|
| ADV   | 20   | Dwell frequency during acceleration | Acc Dwell Freq | 5.00              | Start frequency – Maximum frequency | Hz   |
|       | 21   | Operation time during acceleration  | Acc Dwell Time | 0.0               | 0.0–60.0                            | sec  |
|       | 22   | Dwell frequency during deceleration | Dec Dwell Freq | 5.00              | Start frequency – Maximum frequency | Hz   |
|       | 23   | Operation time during deceleration  | Dec Dwell Time | 0.0               | 0.0–60.0                            | sec  |

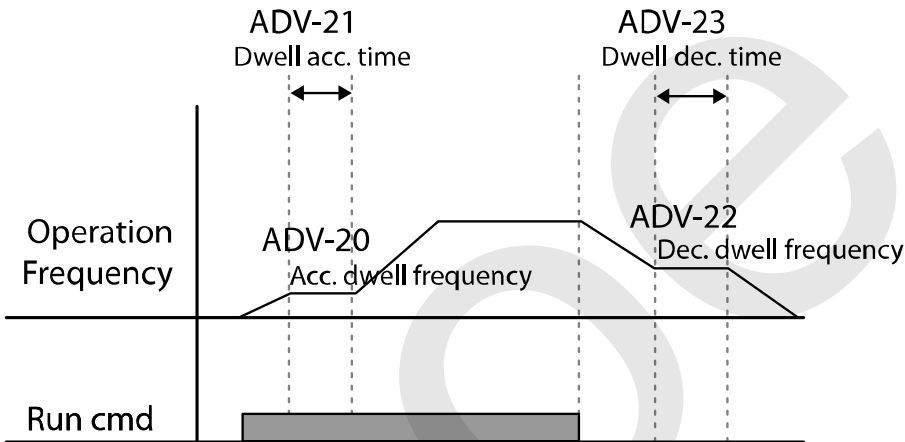

**Note**

**Dwell operations are not performed when:**

- The dwell operation time is set to 0 sec or the dwell frequency is set to 0 Hz.
- Re-acceleration is attempted from a stop or during deceleration, since only the first acceleration dwell operation command is valid.

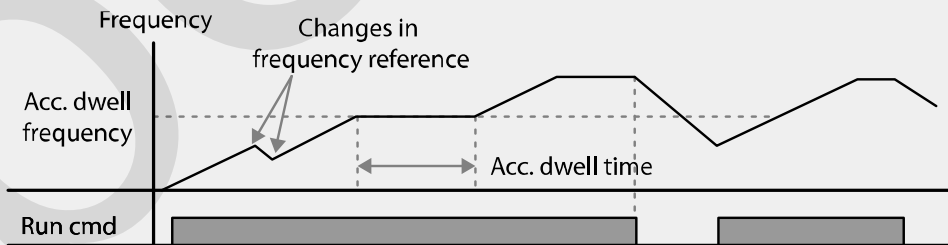

[Acceleration dwell operation]

- Although a deceleration dwell operation is carried out whenever stop commands are entered and the deceleration dwell frequency is passed through, it does not work during a deceleration operation by a simple frequency change (which is not deceleration due to a stop operation), or during external brake control applications.

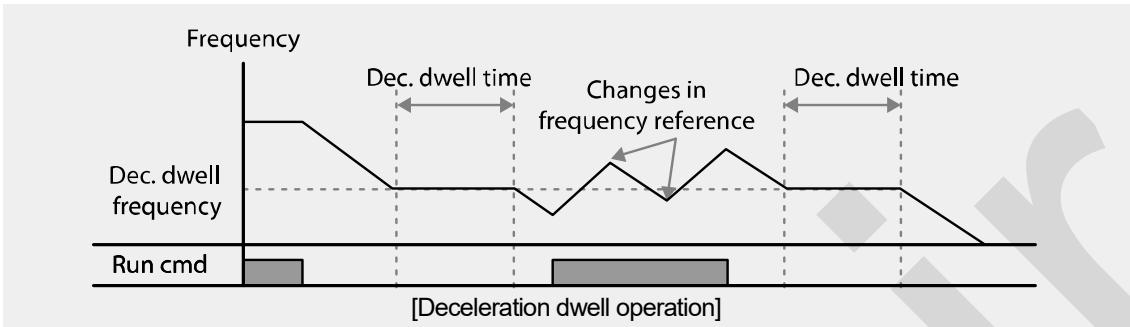

## 8.7 Slip Compensation Operation

Slip refers to the variation between the setting frequency (synchronous speed) and motor rotation speed. As the load increases, there can be variations between the setting frequency and motor rotation speed. Slip compensation is used for loads that require compensation of these speed variations.\*

Motor Rotation

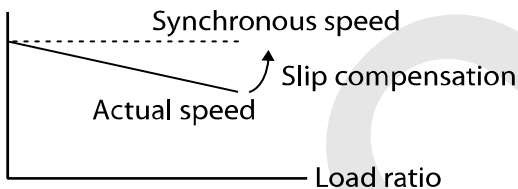

\*If DRV-09 is set to Sensorless, Vector, or V/F PG, the variation (slip) is automatically compensated.

| Group | Code | Name                  | LCD Display    | Parameter Setting            | Setting Range | Unit |
|-------|------|-----------------------|----------------|------------------------------|---------------|------|
| DRV   | 09   | Control mode          | Control Mode   | 2 Slip Compen                | 0-5           | -    |
|       | 14   | Motor Capacity        | Motor Capacity | 2 0.75 kW<br>(0.75 kW based) | 0.2-450       | kW   |
| BAS   | 11   | Number of motor poles | Pole Number    | 4                            | 2-48          | -    |
|       | 12   | Rated slip speed      | Rated Slip     | 90 (0.75 kW based)           | 0-3000        | rpm  |
|       | 13   | Rated motor current   | Rated Curr     | 3.6 (0.75 kW based)          | 1-10000       | A    |
|       | 14   | Motor no-load current | Noload Curr    | 1.6 (0.75 kW based)          | 0.5-1000      | A    |
|       | 16   | Motor efficiency      | Efficiency     | 72 (0.75 kW based)           | 70-100        | %    |
|       | 17   | Load Inertia ratio    | Inertia Rate   | 0 (0.75 kW based)            | 0-8           | -    |
| ADV   | 92   | SlipGain Mot-H        | SlipGain Mot-H | 50                           | 0-200         | %    |

| Group | Code | Name           | LCD Display    | Parameter Setting | Setting Range | Unit |
|-------|------|----------------|----------------|-------------------|---------------|------|
|       | 93   | SlipGain Gen-H | SlipGain Gen-H | 50                | 0-200         | %    |
|       | 94   | SlipGain Mot-L | SlipGain Mot-L | 50                | 0-200         | %    |
|       | 95   | SlipGain Gen-L | SlipGain Gen-L | 50                | 0-200         | %    |
|       | 96   | Slip Filter    | Slip Filter    | 300               | 0-10000       | msec |
|       | 97   | Slip Comp Freq | Slip Comp Freq | 5.00              | 0-60.00       | Hz   |
|       | 98   | Slip Gain Freq | Slip Gain Freq | 9.00              | 0-20.00       | Hz   |

### Slip Compensation Operation–Setting Details

| Code   | Description   |
|--|---|
| DRV-09 Control Mode                              | Sets DRV-09 to “2 (Slip Compen)” to carry out the slip compensation operation.  |
| DRV-14 Motor Capacity                            | Sets the capacity of the motor connected to the inverter.   |
| BAS-11 Pole Number                               | Enters the number of poles from the motor rating plate.   |
| BAS-12 Rated Slip                                | Enters the number of rated rotations from the motor rating plate.   |
| BAS-13 Rated Curr                                | Enters the rated current from the motor rating plate.   |
| BAS-14 Noload Curr                               | Enters the measured current when the load on the motor axis is removed and when the motor is operated at the rated frequency. If the no-load current is difficult to measure, enter a current equivalent to 30-50% of the rated motor current.  |
| BAS-16 Efficiency                                | Enters the efficiency from the motor rating place.  |
| BAS-17 Inertia Rate                              | If inertia rate < 10 x motor inertia, set BAS-16 to “0”.<br>If inertia rate = 10 x motor inertia, set BAS-16 to “1”.<br>If inertia rate > 10 x motor inertia, set BAS-16 to “2–8”.  |
| ADV-92 Slip Gain Mot-H<br>ADV-93 Slip Gain Gen-H | This is the slip compensation gain used in the region where the output frequency is higher than the slip compensation gain switching frequency (ADV-98). You can set the gain values differently for the reverse/regeneration operations.   |
| ADV-94 Slip Gain Mot-L<br>ADV-95 Slip Gain Gen-L | This is the slip compensation gain used in the region where the output frequency is lower than the slip compensation gain switching frequency (ADV-98). You can set the gain values differently for the reverse/regeneration operations.  |
| ADV-96 Slip Filter                               | The filter time constant used when calculating the current required for slip compensation.  |
| ADV-97 Slip Comp Freq                            | You can set the frequency at which slip compensation starts.<br>It is used when load compensation is not performed properly due to a low load compensation amount when stopped.<br>At a constant speed, when it is above this frequency setting value, it calculates the real time slip to compensate the load. If it is below, it compensates the load |

| Code                  | Description  |
|-----------------------|--|
|                       | by using the previously calculated slip. When accelerating, the load is compensated by carrying out the sleep operation regardless of this frequency value. When decelerated, the load is compensated by using the previous calculated slip regardless of this frequency.<br>When this value is set to 0, the slip operation is compensated in real time at all frequencies regardless of acceleration/deceleration and constant speed |
| ADV-98 Slip Gain Freq | Input using the rated speed of the motor nameplate   |

### Note

The following is a formula for calculating the rated slip:

$$f_s = \frac{f_r \times 120}{P} - Rpm$$

$f_s$ = Rated slip frequency,  $f_r$ = Rated frequency

$Rpm$ = Number of rated motor rotations,  $P$ = Number of motor poles

Ex.) If the rated frequency is 60 Hz, the rated revolution is 1740 rpm, and the pole number is 4:

$$f_s = \frac{60 \times 120}{4} - 1740 = 60rpm$$

## 8.8 PID Control

PID control is one of the most common auto-control methods. It uses a combination of proportional, integral, and differential (PID) controls that provide more effective control for automated systems. The functions of PID control that can be applied to the inverter operation are as follows:

| Purpose             | Function   |
|---------------------|--|
| Speed Control       | Controls the speed by monitoring the current speed levels of the equipment or machinery being controlled. This control maintains a consistent speed or operates at the target speed.                         |
| Pressure Control    | Controls the pressure by monitoring the current pressure levels of the equipment or machinery being controlled. This control maintains a consistent pressure or operates at the target pressure.             |
| Flow Control        | Controls the flow by monitoring the current amount of flow in the equipment or machinery being controlled. This control maintains a consistent flow or operates at a target flow.                            |
| Temperature Control | Controls the temperature by monitoring the current temperature levels of the equipment or machinery being controlled. This control maintains a consistent temperature or operates at the target temperature. |

## 8.8.1 PID Basic Operation

PID operates by controlling the output frequency of the inverter, through automated system process control to maintain the speed, pressure, flow, temperature, or tension.

| Group | Code                                    | Name                        | LCD Display    | Parameter Setting |          | Setting Range | Unit                       |    |
|-------|---|-----------------------------|----------------|-------------------|----------|---------------|----------------------------|----|
| APP   | 01                                      | Application mode            | App Mode       | 2                 | Proc PID | 0–4           | -                          |    |
|       | 16                                      | PID output monitor          | PID Output     | -                 |          | -             | -                          |    |
|       | 17                                      | PID reference monitor       | PID Ref Value  | -                 |          | -             | -                          |    |
|       | 18                                      | PID Feedback Value          | PID Fdb Value  | -                 |          | -             | -                          |    |
|       | 19                                      | PID reference setting       | PID Ref Set    | 50.00             |          | -100–100      | %                          |    |
|       | 20                                      | PID reference source        | PID Ref Source | 0                 | Keypad   | 0–10          | -                          |    |
|       | 21                                      | PID feedback source         | PID F/B source | 0                 | V1       | 0–9           | -                          |    |
|       | 22                                      | PID proportional gain       | PID P-Gain     | -                 | 50.0     | 0–1000        | %                          |    |
|       | 23                                      | PID integral time           | PID I-Time     | -                 | 10.0     | 0–200.0       | sec                        |    |
|       | 24                                      | PID differential time       | PID D-Time     | -                 | 0        | 0–1000        | ms                         |    |
|       | 25                                      | PID feed forward gain       | PID F-Gain     | -                 | 0.0      | 0–1000        | %                          |    |
|       | 26                                      | PID proportional gain scale | P Gain Scale   | -                 | 100.0    | 0–100         | %                          |    |
|       | 27                                      | PID output filter           | PID Out LPF    | -                 | 0        | 0–10000       | ms                         |    |
|       | 28                                      | PID mode options            | PID Mode       | 0                 | 0        | Process PID   | 0-1                        | -  |
|       | 29                                      | PID output upper limit      | PID Limit Hi   | -                 | 60.00    |               | APP-30 setting value–300   | Hz |
|       | 30                                      | PID output lower limit      | PID Limit Lo   | -                 | -60.00   |               | -300–APP-029 setting value | Hz |
|       | 31                                      | PID output inversion        | PID Out Inv    | -                 | 0        | No            | 0–1                        | -  |
|       | 32                                      | PID output scale            | PID Out Scale  | -                 | 100.0    |               | 0.1–1000                   | %  |
|       | 34                                      | Pre-PID start frequency     | Pre-PID Freq   | -                 | 0.00     |               | 0–Max. Freq                | Hz |
| 35    | Feedback value to end Pre-PID operation | Pre-PID Exit                | -              | 0.0               |          | 0–100         | %                          |    |

| Group | Code  | Name                        | LCD Display                              | Parameter Setting |              | Setting Range | Unit |
|-------|-------|-----------------------------|--|-------------------|--------------|---------------|------|
|       | 36    | Pre-PID delay time          | Pre-PID Delay                            | -                 | 600          | 0–9999        | sec  |
|       | 37    | PID sleep delay time        | PID Sleep DT                             | -                 | 60.0         | 0–999.9       | sec  |
|       | 38    | PID sleep frequency         | PID Sleep Freq                           | -                 | 0.00         | 0–Max. Freq.  | Hz   |
|       | 39    | PID wakeup level            | PID WakeUp Lev                           | -                 | 35           | 0–100         | %    |
|       | 40    | PID wakeup mode option      | PID WakeUp Mod                           | 0                 | Below Level  | 0–2           | -    |
|       | 41    | PID Rev Run Enable          | PID Rev Run En                           | 0                 | No           | 0-1           | -    |
|       | 42    | PID unit option             | PID Unit Sel                             | 0                 | Hz           | 0–12          | -    |
|       | 43    | PID gain unit               | PID Unit Gain                            | -                 | 100.0        | 0–300         | %    |
|       | 44    | PID scale unit              | PID Unit Scale                           | 2                 | X 1          | 0–2           | -    |
|       | 45    | PID proportional gain 2     | PID P2-Gain                              | -                 | 100.0        | 0–1000        | %    |
| IN    | 65–75 | Px circuit function setting | Px Define (Px: P1–P8 [optional: P9–P11]) | 22                | I-Term Clear | 0–51          | -    |
|       |       |                             |  | 23                | PID Openloop |               |      |
|       |       |                             |  | 24                | P Gain2      |               |      |

## Note

- Normal PID output (PID OUT) is bipolar and is limited by APP-29 (PID Limit Hi) and APP-30 (PID Limit Lo) settings.
- If a PID change operation (changes from PID operation to normal operation) comes into multi-function inputs (P1-P11), the value of [%] is converted to [Hz] and is output.
- DRV-20 (MaxFreq) value equals 100% of PID output.

## PID Basic Operation Setting Details

| Code                 | Description  |
|----------------------|--|
| APP-01 App Mode      | Sets the code to “2 (Proc PID)” to enable process PID.   |
| APP-16 PID Output    | Displays the existing output value of the PID controller. The unit, gain, and scale set at APP-42, APP-43, and APP-44 are applied on the display.                |
| APP-17 PID Ref Value | Displays the existing reference value set for the PID controller. The unit, gain, and scale set at APP-42, APP-43, and APP-44 are applied on the display.        |
| APP-18 PID Fdb Value | Displays the latest feedback value of the PID controller. The unit, gain, and scale set at APP-42, APP-43, and APP-44 are applied on the display.                |
| APP-19 PID Ref Set   | Sets the reference value when APP-20 (PID Ref Source) is set to “0 (Keypad)”. If the reference source is set to any input other than the keypad, this value will |

| Code                                   | Description   |                |          |                |   |        |   |   |    |   |   |    |   |   |    |   |   |    |   |   |          |   |   |         |   |   |          |   |   |     |   |   |         |   |    |             |   |
|--|---|----------------|----------|----------------|---|--------|---|---|----|---|---|----|---|---|----|---|---|----|---|---|----------|---|---|---------|---|---|----------|---|---|-----|---|---|---------|---|----|-------------|---|
| APP-20 PID Ref Source                  | <p>be ignored.</p> <p>Set the reference input source for the PID control. If the V1 terminal is set as the PID feedback source at APP-21 (PID F/B Source), it cannot be set as the PID reference source. To set V1 as a reference source, change the feedback source settings first.</p> <table border="1" data-bbox="412 436 1245 1049"> <thead> <tr> <th>Setting</th> <th>Function</th> <th>PID F/B Source</th> </tr> </thead> <tbody> <tr> <td>0</td> <td>Keypad</td> <td>X</td> </tr> <tr> <td>1</td> <td>V1</td> <td>O</td> </tr> <tr> <td>2</td> <td>I1</td> <td>O</td> </tr> <tr> <td>3</td> <td>V2</td> <td>O</td> </tr> <tr> <td>4</td> <td>I2</td> <td>O</td> </tr> <tr> <td>5</td> <td>Int. 485</td> <td>O</td> </tr> <tr> <td>6</td> <td>Encoder</td> <td>O</td> </tr> <tr> <td>7</td> <td>FieldBus</td> <td>O</td> </tr> <tr> <td>8</td> <td>PLC</td> <td>O</td> </tr> <tr> <td>9</td> <td>Synchro</td> <td>O</td> </tr> <tr> <td>10</td> <td>Binary Type</td> <td>X</td> </tr> </tbody> </table> <p>The PID reference source setting can be monitored at APP-17 (PID Ref Value) according to the information types for monitoring set at CNF-06–08.</p> | Setting        | Function | PID F/B Source | 0 | Keypad | X | 1 | V1 | O | 2 | I1 | O | 3 | V2 | O | 4 | I2 | O | 5 | Int. 485 | O | 6 | Encoder | O | 7 | FieldBus | O | 8 | PLC | O | 9 | Synchro | O | 10 | Binary Type | X |
| Setting                                | Function  | PID F/B Source |          |                |   |        |   |   |    |   |   |    |   |   |    |   |   |    |   |   |          |   |   |         |   |   |          |   |   |     |   |   |         |   |    |             |   |
| 0                                      | Keypad  | X              |          |                |   |        |   |   |    |   |   |    |   |   |    |   |   |    |   |   |          |   |   |         |   |   |          |   |   |     |   |   |         |   |    |             |   |
| 1                                      | V1  | O              |          |                |   |        |   |   |    |   |   |    |   |   |    |   |   |    |   |   |          |   |   |         |   |   |          |   |   |     |   |   |         |   |    |             |   |
| 2                                      | I1  | O              |          |                |   |        |   |   |    |   |   |    |   |   |    |   |   |    |   |   |          |   |   |         |   |   |          |   |   |     |   |   |         |   |    |             |   |
| 3                                      | V2  | O              |          |                |   |        |   |   |    |   |   |    |   |   |    |   |   |    |   |   |          |   |   |         |   |   |          |   |   |     |   |   |         |   |    |             |   |
| 4                                      | I2  | O              |          |                |   |        |   |   |    |   |   |    |   |   |    |   |   |    |   |   |          |   |   |         |   |   |          |   |   |     |   |   |         |   |    |             |   |
| 5                                      | Int. 485  | O              |          |                |   |        |   |   |    |   |   |    |   |   |    |   |   |    |   |   |          |   |   |         |   |   |          |   |   |     |   |   |         |   |    |             |   |
| 6                                      | Encoder   | O              |          |                |   |        |   |   |    |   |   |    |   |   |    |   |   |    |   |   |          |   |   |         |   |   |          |   |   |     |   |   |         |   |    |             |   |
| 7                                      | FieldBus  | O              |          |                |   |        |   |   |    |   |   |    |   |   |    |   |   |    |   |   |          |   |   |         |   |   |          |   |   |     |   |   |         |   |    |             |   |
| 8                                      | PLC   | O              |          |                |   |        |   |   |    |   |   |    |   |   |    |   |   |    |   |   |          |   |   |         |   |   |          |   |   |     |   |   |         |   |    |             |   |
| 9                                      | Synchro   | O              |          |                |   |        |   |   |    |   |   |    |   |   |    |   |   |    |   |   |          |   |   |         |   |   |          |   |   |     |   |   |         |   |    |             |   |
| 10                                     | Binary Type   | X              |          |                |   |        |   |   |    |   |   |    |   |   |    |   |   |    |   |   |          |   |   |         |   |   |          |   |   |     |   |   |         |   |    |             |   |
| APP-21 PID F/B Source                  | <p>Sets a feedback input source for the PID control. Keypad input (keypad-1, keypad-2) cannot be selected as the source of FB input. Also, the input type selected as the PID input source at APP-19 (PID Ref Set) cannot be set as the PID feedback input source.</p> <p>For example, if the V1 terminal is set as the PID reference source at APP-20, you must select input types other than the V1 terminal as the PID feedback source.</p> <p>You can set codes 06–08 in the CNF group to “18 (PID Fdb Value)” to monitor the feedback values.</p>  |                |          |                |   |        |   |   |    |   |   |    |   |   |    |   |   |    |   |   |          |   |   |         |   |   |          |   |   |     |   |   |         |   |    |             |   |
| APP-22 PID P-Gain, APP-26 P Gain Scale | <p>Sets the output ratio for differences (errors) between the reference and feedback. If the P-gain is set to 50%, then 50% of the difference (error) is output.</p> <p>The setting range of P-gain is 0.0–1000.0%. You can set APP-26 (P-Gain Scale) to adjust the input scale if a more accurate control is required.</p>   |                |          |                |   |        |   |   |    |   |   |    |   |   |    |   |   |    |   |   |          |   |   |         |   |   |          |   |   |     |   |   |         |   |    |             |   |
| APP-23 PID I-Time                      | <p>Sets the time to output accumulated errors. When the error is 100%, the time taken for 100% output is set. When the integral time (PID I-Time) is set to 1 second, 100% output occurs after 1 second of the error and remains at 100%. Differences in a normal state can be reduced by PID I Time. When the multi-function terminal block is set to “21 (I-Term Clear)” and is turned on, all of the accumulated errors are deleted.</p>   |                |          |                |   |        |   |   |    |   |   |    |   |   |    |   |   |    |   |   |          |   |   |         |   |   |          |   |   |     |   |   |         |   |    |             |   |



| Code   | Description  |             |                                   |   |             |   |   |   |   |   |     |          |   |   |      |   |    |   |     |   |    |       |  |   |     |   |   |         |   |   |   |         |   |    |                |    |    |             |    |    |             |                                   |    |    |
|--|--|-------------|-----------------------------------|---|-------------|---|---|---|---|---|-----|----------|---|---|------|---|----|---|-----|---|----|-------|--|---|-----|---|---|---------|---|---|---|---------|---|----|----------------|----|----|-------------|----|----|-------------|-----------------------------------|----|----|
| APP-24 PID D-Time                              | Sets the output volume for the rate of change in errors. If the differential time (PID D-Time) is set to 1 ms and the rate of change in errors per sec is 100%, output occurs at 1% per 10 ms.   |             |                                   |   |             |   |   |   |   |   |     |          |   |   |      |   |    |   |     |   |    |       |  |   |     |   |   |         |   |   |   |         |   |    |                |    |    |             |    |    |             |                                   |    |    |
| APP-25 PID F-Gain                              | Sets the ratio that adds the target to the PID output. Adjusting this value leads to a faster response.  |             |                                   |   |             |   |   |   |   |   |     |          |   |   |      |   |    |   |     |   |    |       |  |   |     |   |   |         |   |   |   |         |   |    |                |    |    |             |    |    |             |                                   |    |    |
| APP-27 PID Out LPF                             | Used when the PID controller output changes too quickly or the entire system is unstable, due to severe oscillation. In general, a lower value (default value is 0) is used to speed up response time, but in some cases a higher value increases stability. The higher the value, the more stable the PID controller output is, but the slower the response time.   |             |                                   |   |             |   |   |   |   |   |     |          |   |   |      |   |    |   |     |   |    |       |  |   |     |   |   |         |   |   |   |         |   |    |                |    |    |             |    |    |             |                                   |    |    |
| APP-28 PID Mode                                | Set APP-28 to “0 (Process PID)” to add certain target values to the PID output to produce the final output.<br>Set APP-28 to “1 (Normal PID)” to use the PID output without additional processing (modification).  |             |                                   |   |             |   |   |   |   |   |     |          |   |   |      |   |    |   |     |   |    |       |  |   |     |   |   |         |   |   |   |         |   |    |                |    |    |             |    |    |             |                                   |    |    |
| APP-29 PID Limit Hi,<br>APP-30 PID Limit Lo    | Sets the values to limit the output of the PID controller.   |             |                                   |   |             |   |   |   |   |   |     |          |   |   |      |   |    |   |     |   |    |       |  |   |     |   |   |         |   |   |   |         |   |    |                |    |    |             |    |    |             |                                   |    |    |
| APP-32 PID Out Scale                           | Sets APP-32 to adjust the scale of the controller output.  |             |                                   |   |             |   |   |   |   |   |     |          |   |   |      |   |    |   |     |   |    |       |  |   |     |   |   |         |   |   |   |         |   |    |                |    |    |             |    |    |             |                                   |    |    |
| PID Rev Run En                                 | Default is set to “No”. When set to “No”, the lower limit frequency limit is set to 0 Hz when the frequency is decreased via PID control, so that it does not reverse. If it is set to “Yes”, when the frequency decreases by PID control, it falls below 0 Hz and operates in the reverse direction.  |             |                                   |   |             |   |   |   |   |   |     |          |   |   |      |   |    |   |     |   |    |       |  |   |     |   |   |         |   |   |   |         |   |    |                |    |    |             |    |    |             |                                   |    |    |
| APP-42 PID Unit Sel                            | Set APP-42 to select the unit for the PID control.   |             |                                   |   |             |   |   |   |   |   |     |          |   |   |      |   |    |   |     |   |    |       |  |   |     |   |   |         |   |   |   |         |   |    |                |    |    |             |    |    |             |                                   |    |    |
|  | <table border="1"> <thead> <tr> <th>Setting</th> <th>Unit</th> <th>Application</th> <th>Description</th> </tr> </thead> <tbody> <tr> <td>0</td> <td>%</td> <td>-</td> <td>Displays certain values into as a percentage.</td> </tr> <tr> <td>1</td> <td>Bar</td> <td rowspan="4">Pressure</td> <td rowspan="4">Units for expressing different types of pressure.</td> </tr> <tr> <td>2</td> <td>mBar</td> </tr> <tr> <td>3</td> <td>Pa</td> </tr> <tr> <td>4</td> <td>kPa</td> </tr> <tr> <td>5</td> <td>Hz</td> <td rowspan="2">Speed</td> <td rowspan="2">Units for inverter output frequency or motor revolution.</td> </tr> <tr> <td>6</td> <td>rpm</td> </tr> <tr> <td>7</td> <td>V</td> <td>Voltage</td> <td rowspan="4">Units for electric voltage, current, electrical consumption, or consumed power.</td> </tr> <tr> <td>8</td> <td>I</td> <td>Current</td> </tr> <tr> <td>9</td> <td>kW</td> <td>Electric power</td> </tr> <tr> <td>10</td> <td>HP</td> <td>Horse power</td> </tr> <tr> <td>11</td> <td>°F</td> <td rowspan="2">Temperature</td> <td rowspan="2">Units for expressing temperature.</td> </tr> <tr> <td>12</td> <td>°C</td> </tr> </tbody> </table> | Setting     | Unit                              | Application   | Description | 0 | % | - | Displays certain values into as a percentage. | 1 | Bar | Pressure | Units for expressing different types of pressure. | 2 | mBar | 3 | Pa | 4 | kPa | 5 | Hz | Speed | Units for inverter output frequency or motor revolution. | 6 | rpm | 7 | V | Voltage | Units for electric voltage, current, electrical consumption, or consumed power. | 8 | I | Current | 9 | kW | Electric power | 10 | HP | Horse power | 11 | °F | Temperature | Units for expressing temperature. | 12 | °C |
|  | Setting  | Unit        | Application                       | Description   |             |   |   |   |   |   |     |          |   |   |      |   |    |   |     |   |    |       |  |   |     |   |   |         |   |   |   |         |   |    |                |    |    |             |    |    |             |                                   |    |    |
|  | 0  | %           | -                                 | Displays certain values into as a percentage.                                   |             |   |   |   |   |   |     |          |   |   |      |   |    |   |     |   |    |       |  |   |     |   |   |         |   |   |   |         |   |    |                |    |    |             |    |    |             |                                   |    |    |
|  | 1  | Bar         | Pressure                          | Units for expressing different types of pressure.                               |             |   |   |   |   |   |     |          |   |   |      |   |    |   |     |   |    |       |  |   |     |   |   |         |   |   |   |         |   |    |                |    |    |             |    |    |             |                                   |    |    |
|  | 2  | mBar        |                                   |   |             |   |   |   |   |   |     |          |   |   |      |   |    |   |     |   |    |       |  |   |     |   |   |         |   |   |   |         |   |    |                |    |    |             |    |    |             |                                   |    |    |
|  | 3  | Pa          |                                   |   |             |   |   |   |   |   |     |          |   |   |      |   |    |   |     |   |    |       |  |   |     |   |   |         |   |   |   |         |   |    |                |    |    |             |    |    |             |                                   |    |    |
|  | 4  | kPa         |                                   |   |             |   |   |   |   |   |     |          |   |   |      |   |    |   |     |   |    |       |  |   |     |   |   |         |   |   |   |         |   |    |                |    |    |             |    |    |             |                                   |    |    |
|  | 5  | Hz          | Speed                             | Units for inverter output frequency or motor revolution.                        |             |   |   |   |   |   |     |          |   |   |      |   |    |   |     |   |    |       |  |   |     |   |   |         |   |   |   |         |   |    |                |    |    |             |    |    |             |                                   |    |    |
|  | 6  | rpm         |                                   |   |             |   |   |   |   |   |     |          |   |   |      |   |    |   |     |   |    |       |  |   |     |   |   |         |   |   |   |         |   |    |                |    |    |             |    |    |             |                                   |    |    |
|  | 7  | V           | Voltage                           | Units for electric voltage, current, electrical consumption, or consumed power. |             |   |   |   |   |   |     |          |   |   |      |   |    |   |     |   |    |       |  |   |     |   |   |         |   |   |   |         |   |    |                |    |    |             |    |    |             |                                   |    |    |
|  | 8  | I           | Current                           |   |             |   |   |   |   |   |     |          |   |   |      |   |    |   |     |   |    |       |  |   |     |   |   |         |   |   |   |         |   |    |                |    |    |             |    |    |             |                                   |    |    |
|  | 9  | kW          | Electric power                    |   |             |   |   |   |   |   |     |          |   |   |      |   |    |   |     |   |    |       |  |   |     |   |   |         |   |   |   |         |   |    |                |    |    |             |    |    |             |                                   |    |    |
| 10   | HP   | Horse power |                                   |   |             |   |   |   |   |   |     |          |   |   |      |   |    |   |     |   |    |       |  |   |     |   |   |         |   |   |   |         |   |    |                |    |    |             |    |    |             |                                   |    |    |
| 11   | °F   | Temperature | Units for expressing temperature. |   |             |   |   |   |   |   |     |          |   |   |      |   |    |   |     |   |    |       |  |   |     |   |   |         |   |   |   |         |   |    |                |    |    |             |    |    |             |                                   |    |    |
| 12   | °C   |             |                                   |   |             |   |   |   |   |   |     |          |   |   |      |   |    |   |     |   |    |       |  |   |     |   |   |         |   |   |   |         |   |    |                |    |    |             |    |    |             |                                   |    |    |
| APP-43 PID Unit Gain,<br>APP-44 PID Unit Scale | Adjust the unit value and scale to fit the unit selected at APP-42 (PID Unit Sel).   |             |                                   |   |             |   |   |   |   |   |     |          |   |   |      |   |    |   |     |   |    |       |  |   |     |   |   |         |   |   |   |         |   |    |                |    |    |             |    |    |             |                                   |    |    |
| APP-45 PID P2-Gain                             | Set APP-45 (PID P2-Gain) for an alternative PID controller gain and use the alternative gain via a terminal input.<br>Set IN-65–75 to “23 (P Gain2)”. When the selected terminal is on, the gain set at APP-45 is used instead of the gain set at APP-22 and APP-23.   |             |                                   |   |             |   |   |   |   |   |     |          |   |   |      |   |    |   |     |   |    |       |  |   |     |   |   |         |   |   |   |         |   |    |                |    |    |             |    |    |             |                                   |    |    |

PID Control Block Diagram

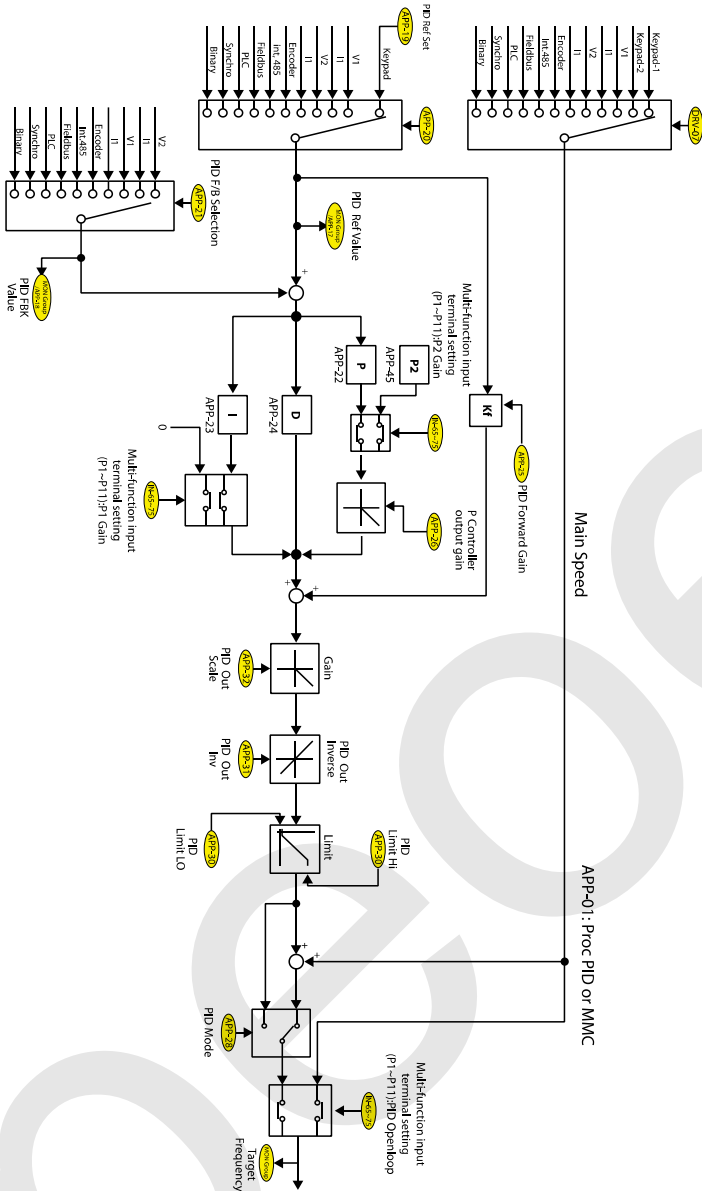

Note

- If the PID switching operation (switching from PID operation to normal operation) is performed at the multi-function inputs (P1-P11), % values are converted into Hz values.
- The polarity of the Normal PID output PID OUT is unipolar, and is limited by APP-29 (PID Limit Hi) and APP-30 (PID Limit Lo).
- 100% is based on the setting at DRV-20 (maxFreq).

## 8.8.2 Pre-PID Operation

Pre-PID operation refers to a section of a PID operation where the inverter runs without PID control. The inverter accelerates to a set frequency and runs without PID control, and then the PID control begins after the PID output exceeds the set value at APP-35 (Pre-PID Exit).

| Code                 | Description  |
|----------------------|--|
| APP-34 Pre-PID Frq   | Sets the target frequency to operate without PID control. The inverter continues running at the set frequency until the PID feedback exceeds the feedback value (%) set at APP-35.   |
| APP-35 Pre-PID Exit  | <p>Sets the feedback value of the PID control (PID reference) to stop pre-PID operation and start PID control.</p> <p>The diagram illustrates the control signals over time. It features four main vertical axes: PID Reference, Feedback, Output Frequency, and FX. At the start of Area 1, the Output Frequency ramps up to a level labeled 'APP-34 Pre-PID freq'. Simultaneously, the Feedback signal ramps up. The PID Reference signal is a step function that jumps to a higher level at the start of Area 1. At the end of Area 1, the Feedback signal crosses the PID Reference signal, and this point is marked as 'APP-35 Pre-PID Exit'. In Area 2, the Feedback signal remains above the PID Reference signal, and the Output Frequency remains constant at the 'APP-34 Pre-PID freq' level. The FX signal is shown as a horizontal line that drops to a lower level at the start of Area 1 and returns to its original level at the start of Area 2.</p> |
| APP-36 Pre-PID Delay | Sets the time until a pre-PID fault trip occurs. If a feedback smaller than the PID reference set at APP-35 is maintained for the set time, a pre-PID fail trip occurs and inverter output is stopped.   |

### 8.8.3 PID Sleep Mode

If an operation continues at a frequency lower than the PID operation conditions at APP-38 (Sleep Freq) for a set duration at APP-37 (PID Sleep DT), the inverter enters PID sleep mode. In PID sleep mode, the inverter resumes PID operation when the PID Wakeup level conditions set at APP-39 (PID WakeUp Lev) are met.

| Code  | Description   |
|---|---|
| APP-37 PID Sleep DT,<br>APP-38 PID Sleep Freq   | Sets the PID sleep frequency and delay time. The inverter stops operation and enters sleep mode if an operation is maintained at a frequency lower than the sleep frequency set at APP-38 for the time set at APP-37.   |
| APP-39 PID WakeUp Lev,<br>APP-40 PID WakeUp Mod | <p>Sets the reference for PID wakeup at APP-39. If APP-40 is set to "0 (Below Level)", PID operation is resumed when the feedback volume is lower than the reference.</p> <p>If APP-40 is set to "0 (Below level)", PID operation will resume when the feedback volume is lower than the reference.</p> <p>If APP-40 is set to "1 (Above Level)", PID operation will resume when the feedback volume is higher than the reference.</p> <p>If APP-40 is set to "2 (Beyond level)", PID operation will resume when the difference between the speed reference and the feedback is larger than the wakeup reference set at APP-39.</p> |

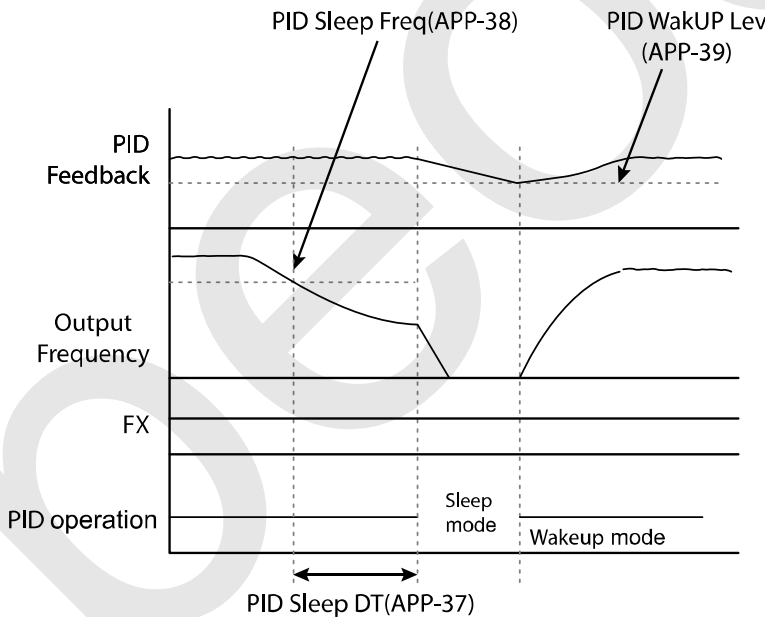

### 8.8.4 PID Switching (PID Openloop)

When one of the multi-function terminals (IN-65–75) is set to “22 (PID Openloop)” and is turned on, the PID operation stops and is switched to general operation. When the terminal turns off, the PID operation starts again.

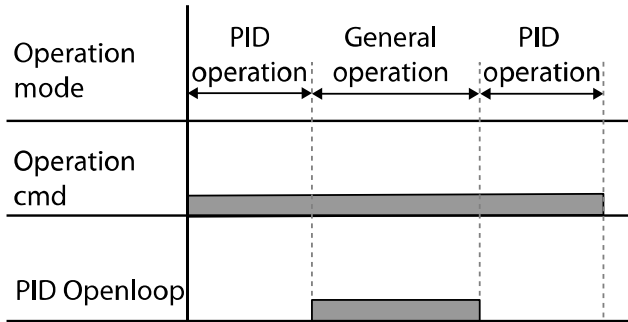

### 8.9 Auto Tuning

The motor parameters can be measured automatically and can be used for an auto torque boost or sensorless vector control.

#### Example - Auto Tuning Based on 0.75 kW, 220 V Motor

| Group | Code | Name                  | LCD Display    | Parameter Setting |         | Unit |
|-------|------|-----------------------|----------------|-------------------|---------|------|
| DRV   | 14   | Motor capacity        | Motor Capacity | 2                 | 0.75 kW | kW   |
| BAS   | 11   | Motor pole number     | Pole Number    | 4                 |         | -    |
|       | 12   | Rated slip speed      | Rated Slip     | 40                |         | Rpm  |
|       | 13   | Rated motor current   | Rated Curr     | 3.6               |         | A    |
|       | 14   | Motor no-load current | Noload curr    | 1.6               |         | A    |
|       | 15   | Motor rated voltage   | Rated Volt     | 220               |         | V    |
|       | 16   | Motor efficiency      | Efficiency     | 72                |         | %    |
|       | 20   | Auto tuning           | Auto Tuning    | 0                 | None    | -    |
|       | 21   | Stator resistance     | Rs             | 2.600             |         | Ω    |
|       | 22   | Leakage inductance    | Lsigma         | 17.94             |         | mH   |
|       | 23   | Stator inductance     | Ls             | 15.44             |         | mH   |
|       | 24   | Rotor time constant   | Tr             | 145               |         | ms   |
| APO   | 01   | Encoder option mode   | Enc Opt Mode   | 0                 | None    |      |

## Auto Tuning Default Parameter Setting

| Motor Capacity (kW) | Rated Current (A) | No-load Current (A) | Rated Slip Frequency (Hz) | Stator Resistance ( $\Omega$ ) | Leakage Inductance (mH) | Stator Inductance [mH] | Rotator Time constant [ms] |     |
|---------------------|-------------------|---------------------|---------------------------|--------------------------------|-------------------------|------------------------|----------------------------|-----|
| 200 V               | 0.2               | 1.1                 | 0.8                       | 3.33                           | 14.0                    | 40.4                   | 385                        | 93  |
|                     | 0.4               | 2.4                 | 1.4                       | 3.33                           | 6.70                    | 26.9                   | 206                        | 116 |
|                     | 0.75              | 3.4                 | 1.7                       | 3.00                           | 2.600                   | 17.94                  | 174.4                      | 145 |
|                     | 1.5               | 6.4                 | 2.6                       | 2.67                           | 1.170                   | 9.29                   | 115.8                      | 162 |
|                     | 2.2               | 8.6                 | 3.3                       | 2.33                           | 0.840                   | 6.63                   | 90.7                       | 183 |
|                     | 3.7               | 13.8                | 5.0                       | 2.33                           | 0.500                   | 4.48                   | 59.7                       | 211 |
|                     | 5.5               | 21.0                | 7.1                       | 1.50                           | 0.314                   | 3.19                   | 41.5                       | 250 |
|                     | 7.5               | 28.2                | 9.3                       | 1.33                           | 0.169                   | 2.844                  | 31.86                      | 271 |
|                     | 11                | 40.0                | 12.4                      | 1.00                           | 0.120                   | 1.488                  | 23.91                      | 310 |
|                     | 15                | 53.6                | 15.5                      | 1.00                           | 0.084                   | 1.118                  | 19.07                      | 350 |
|                     | 18.5              | 65.6                | 19.0                      | 1.00                           | 0.068                   | 0.819                  | 15.59                      | 390 |
|                     | 22                | 76.8                | 21.5                      | 1.00                           | 0.056                   | 0.948                  | 13.79                      | 435 |
|                     | 30                | 104.6               | 29.3                      | 1.00                           | 0.042                   | 0.711                  | 10.12                      | 530 |
|                     | 37                | 128.6               | 34.7                      | 1.00                           | 0.033                   | 0.568                  | 8.54                       | 600 |
|                     | 45                | 156.0               | 42.1                      | 1.00                           | 0.028                   | 0.474                  | 7.04                       | 630 |
|                     | 55                | 184.1               | 49.7                      | 1.00                           | 0.023                   | 0.389                  | 5.96                       | 670 |
| 75                  | 244.5             | 61.1                | 1.00                      | 0.016                          | 0.284                   | 4.85                   | 800                        |     |
| 90                  | 289.5             | 72.3                | 1.00                      | 0.014                          | 0.250                   | 4.09                   | 900                        |     |
| 400 V               | 0.2               | 0.7                 | 0.5                       | 3.33                           | 28.00                   | 121.2                  | 1045                       | 93  |
|                     | 0.4               | 1.4                 | 0.8                       | 3.33                           | 14.0                    | 80.8                   | 610                        | 116 |
|                     | 0.75              | 2.0                 | 1.0                       | 3.00                           | 7.81                    | 53.9                   | 512                        | 145 |
|                     | 1.5               | 3.7                 | 1.5                       | 2.67                           | 3.52                    | 27.9                   | 346                        | 162 |
|                     | 2.2               | 5.0                 | 1.9                       | 2.33                           | 2.520                   | 19.95                  | 269.5                      | 183 |
|                     | 3.7               | 8.0                 | 2.9                       | 2.33                           | 1.500                   | 13.45                  | 177.8                      | 211 |
|                     | 5.5               | 12.1                | 4.1                       | 1.50                           | 0.940                   | 9.62                   | 124.5                      | 250 |
|                     | 7.5               | 16.3                | 5.4                       | 1.33                           | 0.520                   | 8.53                   | 95.2                       | 271 |
|                     | 11                | 23.2                | 7.2                       | 1.00                           | 0.360                   | 4.48                   | 71.2                       | 310 |
|                     | 15                | 31.0                | 9.0                       | 1.00                           | 0.250                   | 3.38                   | 57                         | 350 |
|                     | 18.5              | 38.0                | 11.0                      | 1.00                           | 0.168                   | 2.457                  | 46.47                      | 390 |
|                     | 22                | 44.5                | 12.5                      | 1.00                           | 0.168                   | 2.844                  | 41.1                       | 435 |
|                     | 30                | 60.5                | 16.9                      | 1.00                           | 0.126                   | 2.133                  | 30.23                      | 530 |
| 37                  | 74.4              | 20.1                | 1.00                      | 0.101                          | 1.704                   | 25.49                  | 600                        |     |

| Motor Capacity (kW) | Rated Current (A) | No-load Current (A) | Rated Slip Frequency (Hz) | Stator Resistance ( $\Omega$ ) | Leakage Inductance (mH) | Stator Inductance [mH] | Rotator Time constant [ms] |
|---------------------|-------------------|---------------------|---------------------------|--------------------------------|-------------------------|------------------------|----------------------------|
| 45                  | 90.3              | 24.4                | 1.00                      | 0.084                          | 1.422                   | 21.01                  | 630                        |
| 55                  | 106.6             | 28.8                | 1.00                      | 0.069                          | 1.167                   | 17.79                  | 670                        |
| 75                  | 141.6             | 35.4                | 1.00                      | 0.050                          | 0.852                   | 14.46                  | 800                        |
| 90                  | 167.6             | 41.9                | 1.00                      | 0.039                          | 0.715                   | 12.22                  | 900                        |
| 110                 | 203.5             | 48.8                | 1.00                      | 0.032                          | 0.585                   | 10.48                  | 1000                       |
| 132                 | 242.3             | 58.1                | 1.00                      | 0.027                          | 0.488                   | 8.8                    | 1100                       |
| 160                 | 290.5             | 69.7                | 1.00                      | 0.022                          | 0.403                   | 7.34                   | 1200                       |
| 185                 | 335.0             | 77.0                | 1.00                      | 0.021                          | 0.380                   | 6.64                   | 1250                       |
| 220                 | 405               | 93.1                | 30                        | 0.0163                         | 0.293                   | 5.467                  | 1350                       |
| 280                 | 530.7             | 116.7               | 30                        | 0.0128                         | 0.23                    | 4.386                  | 1400                       |
| 315                 | 604               | 132.8               | 30                        | 0.0114                         | 0.204                   | 3.854                  | 1430                       |
| 375                 | 729.7             | 153.2               | 30                        | 0.0096                         | 0.171                   | 3.342                  | 1470                       |

## Auto Tuning Parameter Setting Details

| Code                  | Description   |          |          |        |  |       |   |                     |   |
|-----------------------|---|----------|----------|--------|--|-------|---|---------------------|---|
| DRV-14 Motor Capacity | Set the motor capacity. The maximum motor capacity is limited by the inverter's capacity.   |          |          |        |  |       |   |                     |   |
| BAS-20 Auto Tuning    | Select an auto tuning type and run it. Select one of the options and then press the [PROG/ENT] key to run auto tuning.  |          |          |        |  |       |   |                     |   |
|                       | <table border="1"> <thead> <tr> <th>Setting</th> <th>Function</th> </tr> </thead> <tbody> <tr> <td>0 None</td> <td>The auto tuning function is disabled. Also, if you select one of the auto tuning options and run it, the parameter value will revert back to 0 when auto tuning is complete.</td> </tr> <tr> <td>1 All</td> <td>Measures all motor parameters while the motor is rotating, including stator resistance (Rs), stator inductance (Lsigma), no-load current (Noload Curr), rotor time constant (Tr), etc.<br/>If an optional encoder module is installed, the inverter state is also measured (requires appropriate settings for encoder-related functions).<br/>Use this setting when DRV-09 (Control mode) is set to "5 (Vector)". Since the motor is rotating while the parameters are being measured, if the load is connected to the motor spindle, the parameters may not be measured accurately. For accurate measurements, remove the load attached to the motor spindle.<br/>If DRV-09 (Control mode) is set to "4 (Sensorless-2)", the rotor time constant (Tr) must be measured in a stopped position.</td> </tr> <tr> <td>2 All (static type)</td> <td>Measures all parameters while the motor is in the stopped position, including stator resistance (Rs), stator inductance (Lsigma), no-load</td> </tr> </tbody> </table> | Setting  | Function | 0 None | The auto tuning function is disabled. Also, if you select one of the auto tuning options and run it, the parameter value will revert back to 0 when auto tuning is complete. | 1 All | Measures all motor parameters while the motor is rotating, including stator resistance (Rs), stator inductance (Lsigma), no-load current (Noload Curr), rotor time constant (Tr), etc.<br>If an optional encoder module is installed, the inverter state is also measured (requires appropriate settings for encoder-related functions).<br>Use this setting when DRV-09 (Control mode) is set to "5 (Vector)". Since the motor is rotating while the parameters are being measured, if the load is connected to the motor spindle, the parameters may not be measured accurately. For accurate measurements, remove the load attached to the motor spindle.<br>If DRV-09 (Control mode) is set to "4 (Sensorless-2)", the rotor time constant (Tr) must be measured in a stopped position. | 2 All (static type) | Measures all parameters while the motor is in the stopped position, including stator resistance (Rs), stator inductance (Lsigma), no-load |
|                       | Setting   | Function |          |        |  |       |   |                     |   |
| 0 None                | The auto tuning function is disabled. Also, if you select one of the auto tuning options and run it, the parameter value will revert back to 0 when auto tuning is complete.  |          |          |        |  |       |   |                     |   |
| 1 All                 | Measures all motor parameters while the motor is rotating, including stator resistance (Rs), stator inductance (Lsigma), no-load current (Noload Curr), rotor time constant (Tr), etc.<br>If an optional encoder module is installed, the inverter state is also measured (requires appropriate settings for encoder-related functions).<br>Use this setting when DRV-09 (Control mode) is set to "5 (Vector)". Since the motor is rotating while the parameters are being measured, if the load is connected to the motor spindle, the parameters may not be measured accurately. For accurate measurements, remove the load attached to the motor spindle.<br>If DRV-09 (Control mode) is set to "4 (Sensorless-2)", the rotor time constant (Tr) must be measured in a stopped position.   |          |          |        |  |       |   |                     |   |
| 2 All (static type)   | Measures all parameters while the motor is in the stopped position, including stator resistance (Rs), stator inductance (Lsigma), no-load   |          |          |        |  |       |   |                     |   |

| Code   | Description   |   |
|--|---|---|
|  |   | current (Noload Curr), rotor time constant (Tr), etc.<br>Use this setting when DRV-09 (Control mode) is set to "4 (Sensorless-2)".<br>Since the motor is not rotating while the parameters are measured, the measurements are not affected when the load is connected to the motor spindle.   |
| 3  | Rs+Lsigma   | Measures the stator resistance (Rs) and stator inductance (Lsigma) while the motor is not rotating. The measured values are used for auto torque boost and sensorless vector control. Since the motor is not rotating while the parameters are measured, the measurements are not affected when the load is connected to the motor spindle. |
| 4  | Enc. Test   | Runs auto tuning after installing the optional encoder to the inverter and connecting the encoder cables to the motor. Auto tuning checks the cable connection. Ensure that the encoder related parameters are correctly set before auto tuning.  |
| 5  | Tr  | Uses this setting to measure the rotor time constant (Tr) when DRV-09 (Control mode) is set to "5 (Vector)". The motor rotates during auto tuning.  |
| 6  | Tr (Stdstl)   | Uses this setting to measure the rotor time constant (Tr) when DRV-09 (Control mode) is set to "4 (Sensorless-2)". The motor does not rotate during auto tuning.  |
| BAS-14<br>Noload Curr,<br>BAS-21<br>Rs-BAS-24 Tr | Displays motor parameters measured by auto tuning. For parameters that are not included in the auto tuning measurement list, the default setting will be displayed. |   |

### ⚠ Caution

- Perform auto tuning **ONLY** after the motor has completely stopped running.
- Before you run auto tuning, check the motor pole number, rated slip, rated current, rated voltage, and efficiency on the motor's rating plate and enter the data. The default parameter setting is used for values that are not entered.

### Note

Before checking the encoder status using auto tuning, ensure that the following parameters are correctly set.

| Group | Code | Name                    | LCD Display   | Parameter Setting |             | Unit    |
|-------|------|-------------------------|---------------|-------------------|-------------|---------|
| BAS   | 20   | Auto tuning             | Auto Tuning   | 3                 | Enc Test    | 0-6     |
| APO   | 01   | Encoder option mode     | Enc Opt Mode  | 1                 | Feedback    | 0-2     |
|       | 04   | Encoder type selection  | Enc Type Sel  | 0                 | Line Driver | 0-2     |
|       | 05   | Encoder pulse direction | Enc Pulse Sel | 0                 | (A+B)       | 0-2     |
|       | 06   | Encoder pulse number    | Enc Pulse Num | -                 | 1024        | 10-5000 |



|    |                          |             |   |   |   |
|----|--------------------------|-------------|---|---|---|
| 08 | Encoder feedback monitor | Enc Monitor | - | 0 | - |
|----|--------------------------|-------------|---|---|---|

**Encoder status checking details**

| Code                 | Description   |                                  |                |               |                                  |                |                                 |                  |                                     |
|----------------------|---|----------------------------------|----------------|---------------|----------------------------------|----------------|---------------------------------|------------------|-------------------------------------|
| BAS-20 Auto Tuning   | <p>Sets the auto tuning type to “3 (Enc Test)” to check the encoder connection. The inverter operates in the Fx direction and accelerates to +20 Hz until it decelerates to 0 Hz and continues operating in the Rx direction, accelerating to -20 Hz.</p> <p>BAS-20 parameter value is automatically changed to “None” if a connection error is not detected.</p> <p>The “Enc reverse” message is displayed if the encoder connection is not correct. If this happens, you can change the APO-05 (ENC Pulse Sel) parameter setting to match the actual direction, or swap the two encoder cables that are connected to the motor.</p> |                                  |                |               |                                  |                |                                 |                  |                                     |
| APO-01 ENC Opt Mode  | Sets the encoder option mode to “1 (Feed-back)”.  |                                  |                |               |                                  |                |                                 |                  |                                     |
| APO-04 Enc Type Sel  | <p>Select an encoder type.</p> <table border="1"> <thead> <tr> <th>Setting</th> <th>Output details</th> </tr> </thead> <tbody> <tr> <td>0 Line Driver</td> <td> <p><b>Line driver output</b></p> </td> </tr> <tr> <td>1 Totem or Com</td> <td> <p><b>Totem pole output</b></p> </td> </tr> <tr> <td>2 Open Collector</td> <td> <p><b>Open collector output</b></p> </td> </tr> </tbody> </table>  | Setting                          | Output details | 0 Line Driver | <p><b>Line driver output</b></p> | 1 Totem or Com | <p><b>Totem pole output</b></p> | 2 Open Collector | <p><b>Open collector output</b></p> |
|                      | Setting   | Output details                   |                |               |                                  |                |                                 |                  |                                     |
|                      | 0 Line Driver   | <p><b>Line driver output</b></p> |                |               |                                  |                |                                 |                  |                                     |
| 1 Totem or Com       | <p><b>Totem pole output</b></p>   |                                  |                |               |                                  |                |                                 |                  |                                     |
| 2 Open Collector     | <p><b>Open collector output</b></p>   |                                  |                |               |                                  |                |                                 |                  |                                     |
| APO-05 Enc Pulse Sel | <p>Sets the direction of the encoder output pulse.</p> <p>0: A+B (Fx, for frequency reference) / 1: -(A+B) (Rx)</p>   |                                  |                |               |                                  |                |                                 |                  |                                     |
| APO-06 Enc Pulse Num | Sets the number of output pulses per one motor revolution.  |                                  |                |               |                                  |                |                                 |                  |                                     |
| APO-08 Enc Monitor   | Converts the encoder output into motor speed (Hz or RPM) for monitoring.  |                                  |                |               |                                  |                |                                 |                  |                                     |

## 8.10 V/F Operation Using Speed Sensor

You can install an optional encoder module to the inverter to enhance the accuracy of V/F control. Before operating the inverter, check the encoder connection by running an auto tuning operation.

| Group | Code | Name                           | LCD Display   | Parameter Setting |           | Setting Range | Unit |
|-------|------|--------------------------------|---------------|-------------------|-----------|---------------|------|
| DRV   | 09   | Control mode                   | Control Mode  | 1                 | V/F PG    | 0–5           | -    |
| CON   | 45   | PG operation proportional gain | PG P-Gain     | -                 | 3000      | 0–9999        | -    |
|       | 46   | PG operation integral gain     | PG I-Gain     | -                 | 50        | 0–9999        | -    |
|       | 47   | PG operation maximum slip      | PG Slip Max % | -                 | 100       | 0–200         | %    |
| APO   | 01   | Encoder option mode            | Enc Opt Mode  | 1                 | Feed-back | 0–2           | -    |

### V/F Operation Using Speed Sensor–Details

| Code                               | Description  |
|------------------------------------|--|
| DRV-09 Control Mode                | Sets the control mode to “1 (V/F PG)”. This mode adds a speed controller to a regular V/F mode. The command frequency becomes the speed reference of the speed controller, and the feedback is used as the encoder input.  |
| CON-45 PG P-Gain, CON-46 PG I-Gain | Sets the proportional and integral gain (P-Gain/I-gain) of the speed controller. Higher P-gain results in a faster response. However, excessively high P-gain may lead to unstable operation. Lower I-gain results in a faster response. However, excessively low P-gain may lead to unstable operation. |
| CON-47 PG Slip Max %               | Sets the maximum slip for the speed controller as a percentage (%) based on the rated slip set at BAS-12 (Rated Slip). For example, if CON-47 is set to 90% when the rated slip set at BAS-12 is 30 rpm, the maximum slip for the speed controller becomes 27 rpm, (90% of 30 rpm,).                     |

## 8.11 Sensorless-1 Vector Control

Sensorless-1 vector control mode provides high performance operation without requiring a speed sensor. Motor parameter information is required for sensorless-1 vector control mode. Before operating the inverter in sensorless-1 mode, run auto tuning first.

| Group | Code | Name                  | LCD Display    | Parameter Setting |              | Unit |
|-------|------|-----------------------|----------------|-------------------|--------------|------|
| DRV   | 09   | Control mode          | Control Mode   | 3                 | Sensorless-1 | -    |
|       | 10   | Torque control option | Torque Control | 0                 | No           | -    |

| Group | Code | Name  | LCD Display    | Parameter Setting |           | Unit |
|-------|------|---|----------------|-------------------|-----------|------|
|       | 14   | Motor-rated capacity                            | Motor Capacity | x                 | x.xx      | kW   |
| BAS   | 11   | Motor pole number                               | Pole Number    | -                 | 4         | -    |
|       | 12   | Motor-rated slip                                | Rated Slip     | -                 | 2.00      | Hz   |
|       | 13   | Motor-rated current                             | Rated Curr     | -                 | 3.6       | A    |
|       | 14   | Motor No-load current                           | Noload curr    | -                 | 0.7       | A    |
|       | 15   | Motor-rated voltage                             | Rated Volt     | -                 | 220       | V    |
|       | 16   | Motor efficiency                                | Efficiency     | -                 | 83        | %    |
|       | 20   | Auto tuning options                             | Auto Tuning    | 2                 | Rs+Lsigma | -    |
| CON   | 21   | Sensorless speed controller proportional gain 1 | ASR-SL P Gain1 | -                 | 100.0     | %    |
|       | 22   | Sensorless speed controller integral gain 1     | ASR-SL I Gain1 | -                 | 150       | ms   |

## ⚠ Caution

- For sensorless-1 mode operation, the motor's rated capacity must match the inverter's rated capacity. If the inverter capacity is too large for the installed motor, run the motor in V/F mode.
- Sensorless-1 mode operation does not support multiple motor control (MMC) features. Do not connect multiple motors to one inverter that is operating in sensorless-1 mode.

## Sensorless-1 Vector Control—Details

| Code  | Description  |
|---|--|
| DRV-14 Motor Capacity, BAS-11 Pole Number, BAS-12 Rated Slip, BAS-13 Rated Curr, BAS-15 Rated Volt, BAS-16 Efficiency | Motor parameter information is required for sensorless-1 vector control mode.<br>Check the motor's rating plate for the motor capacity and other performance-related information, set the relevant parameters, and then run auto tuning at BAS-20.   |
| BAS-20 Auto Tuning  | After setting all the parameter values (DRV-14 Motor Capacity, BAS-11 Pole Number, BAS-12 Rated Slip, BAS-13 Rated Curr, BAS-15 Rated Volt, and BAS-16 Efficiency), perform auto tuning.<br><br><b>To perform astatic auto tuning</b> when the motor does not rotate, set BAS-20 to 2 (Rs+Lsigma). The default motor no-load current is used, and the motor stator resistance (Rs) and leakage inductance (Lsigma) values are saved at BAS-21 and BAS-22.<br><br><b>To perform rotating auto tuning</b> , separate the load from the motor axis, if possible, and set BAS-20 to "1 (ALL)". The motor no-load current, motor stator resistance (Rs), and motor leakage inductance (Lsigma) values are |

| Code   | Description   |
|--|---|
|  | saved at BAS-14, BAS-21, and BAS-22 respectively.   |
| CON-21 ASR-SL P Gain1, CON-22 ASR-SL I Gain1 | <p>Set the speed controller proportionately and integral gains for sensorless-1 vector control according to the default motor parameters and acc/dec time.</p> <p><b>⚠ Caution</b><br/>Appropriate controller gain values must be set based on the load characteristics. Motor overheating or an unstable system may result if the gain values are not properly set.</p>  |
| DRV-10 Torque Control                        | <p>Selects the speed control and torque control modes. If you set DRV-10 (Torque control) to “1 (Yes)”, the operation switches into torque control mode. Refer to <a href="#">8.14 Torque Control</a> on page <a href="#">236</a> for details.</p> <p><b>⚠ Caution</b></p> <ul style="list-style-type: none"> <li>• Torque control is not available during low-speed regeneration and low-speed operation under a light load. Select vector control mode instead.</li> <li>• When the inverter is operated in torque control mode, do not switch between forward and reverse rotations. Overcurrent or Rx deceleration fault trips may result.</li> <li>• When the inverter is operated in sensorless vector control mode, enable accelerating speed search by setting the CON-71 (Speed search) bits to “0001” if the inverter is expected to start or restart while the motor is free-running.</li> </ul> |

## 8.12 Sensorless-2 Vector Control

Similar to sensorless-1 vector control mode, sensorless-2 vector control mode provides high-performance inverter operation without requiring a speed sensor. It utilizes various gain values for more precise vector control.

Motor parameter information is required for sensorless-2 vector control mode. Before operating the inverter in sensorless-2 mode, run auto tuning first.

| Group | Code | Name                  | LCD Display    | Parameter Setting                       | Unit |
|-------|------|-----------------------|----------------|---|------|
| DRV   | 09   | Control mode          | Control Mode   | 4   Sensorless-2                        | -    |
|       | 10   | Torque control option | Torque Control | 0   No                                  | -    |
|       | 14   | Motor-rated capacity  | Motor Capacity | x   Varies depending on motor capacity. | kW   |
| BAS   | 11   | Motor pole number     | Pole Number    | -   4                                   | -    |
|       | 12   | Motor-rated slip      | Rated Slip     | -   Varies depending on motor capacity. | Hz   |

| Group | Code | Name  | LCD Display    | Parameter Setting | Unit                                |    |
|-------|------|---|----------------|-------------------|-------------------------------------|----|
|       | 13   | Motor-rated current                             | Rated Curr     | -                 | Varies depending on motor capacity. | A  |
|       | 14   | Motor No-load current                           | Noload curr    | -                 | Varies depending on motor capacity. | A  |
|       | 15   | Motor-rated voltage                             | Rated Volt     | -                 | 220/380/440/480                     | V  |
|       | 16   | Motor efficiency                                | Efficiency     | -                 | Varies depending on motor capacity. | %  |
|       | 20   | Auto tuning options                             | Auto Tuning    | 1                 | All                                 | -  |
| CON   | 20   | Sensorless 2nd gain display setting             | SL2 G View Sel | 1                 | Yes                                 | -  |
|       | 21   | Sensorless speed controller proportional gain 1 | ASR-SL P Gain1 | -                 | Varies depending on motor capacity. | %  |
|       | 22   | Sensorless speed controller integral gain 1     | ASR-SL I Gain1 | -                 | Varies depending on motor capacity. | ms |
|       | 23   | Sensorless speed controller proportional gain 2 | ASR-SL P Gain2 | -                 | Varies depending on motor capacity. | %  |
|       | 24   | Sensorless2 speed controller integral gain 2    | ASR-SL I Gain2 | -                 | Varies depending on motor capacity. | %  |
|       | 26   | Sensorless2 measurer gain 1                     | Observer Gain1 | -                 | 10500                               | -  |
|       | 27   | Sensorless2 measurer gain 2                     | Observer Gain2 | -                 | 100.0                               | %  |
|       | 28   | Sensorless2 measurer gain 3                     | Observer Gain3 | -                 | 13000                               | -  |
|       | 29   | Sensorless2 speed estimator proportional gain 1 | S-Est P Gain 1 | -                 | Varies depending on motor capacity. | -  |
|       | 30   | Sensorless2 speed estimator integral gain 1     | S-Est I Gain 1 | -                 | Varies depending on motor capacity. | -  |
|       | 31   | Sensorless2 speed estimator proportional gain 2 | S-Est P Gain 2 | -                 | Varies depending on motor capacity. | %  |
|       | 32   | Sensorless2 speed estimator integral gain 2     | S-Est I Gain 2 | -                 | Varies depending on motor capacity. | %  |
|       | 48   | Current controller P gain                       | ACR P-Gain     | -                 | 1200                                | -  |
|       | 49   | Current controller I gain                       | ACR I-Gain     | -                 | 120                                 | -  |

### ⓘ Caution

- For sensorless-2 mode operation, the motor-rated capacity must match the inverter's rated capacity. If the inverter capacity is too large for the installed motor, run the motor in V/F mode.
- Sensorless-2 mode does not support multiple motor control (MMC) features. Do not connect multiple motors to one inverter that is operating in sensorless-1 mode.

## Sensorless-2 Vector Control–Details

| Code   | Description  |
|--|--|
| DRV-14 Motor Capacity,<br>BAS-11 Pole Number,<br>BAS-12 Rated Slip,<br>BAS-13 Rated Curr,<br>BAS-15 Rated Volt,<br>BAS-16 Efficiency | <p>Motor parameter information is required for sensorless-2 vector control mode.</p> <p>Check the motor's rating plate for the motor capacity and other performance related information, set the relevant parameters, and then run auto tuning at BAS-20.</p>  |
| BAS-20 Auto Tuning   | <p>After setting all the parameter values (DRV-14 Motor Capacity, BAS-11 Pole Number, BAS-12 Rated Slip, BAS-13 Rated Curr, BAS-15 Rated Volt, and BAS-16 Efficiency), perform a rotating auto tuning.</p> <p><b>To perform rotating auto tuning</b>, separate the load from the motor axis, and set BAS-20 to "1 (ALL)". The motor stator resistance (Rs), leakage inductance (Lsigma), stator inductance (Ls), no-load current (Noload Curr), and rotor time constant (Tr) are saved in BAS-21, BAS-22, BAS-23, BAS-14, and BAS-24, respectively.</p>  |
| CON-20 SL2 G View Sel  | <p>Set CON-20 to "1 (Yes)" to view various medium speed* gains (CON-23 ASR-SL P Gain2, CON-24 ASR-SL I Gain2, CON-27 Observer Gain2, CON-28 Observer Gain3, CON-31 S-Est P Gain2, and CON-32 S-Est I Gain2) for user configuration. These parameters are not visible if CON-20 is set to "0 (No)".</p> <p>*Medium speed: A speed range that is approximately 50% of the base frequency.</p>  |
| CON-21 ASR-SL P Gain1,<br>CON-22 ASR-SL I Gain1  | <p>Sets the speed controller proportionately and integral gain values for sensorless-2 vector control.</p> <p>The P-gain is proportionate to speed deviation. Increasing the P-gain increases torque output and immediately eliminates speed deviation.</p> <p>The I-gain is an integral gain which represents the time (ms) until the torque output is made under a steady speed deviation. Decreasing the I-gain can eliminate the speed deviation faster.</p> <p>After setting the speed controller gain values, observe the changes and fine-tune the values to improve the speed control waveforms. Note that vibration may result if the set P-gain value is too large or the set I-gain value is too small. If oscillation is observed in the waveform, first increase the I-gain, and then increase the P-gain to find the optimal values.</p> |
| CON-23 ASR-SL P Gain2,<br>CON-24 ASR-SL I Gain2  | <p>These codes are visible only when CON-20 is set to "1 (yes)".</p> <p>Set the speed controller proportionately and integral gain values for sensorless-2 vector control for operation speeds greater than 50% of the base frequency.</p> <p>CON-23 (ASR-SL P Gain2) and CON-24 (ASR-SL I Gain2) are set as percentage values (%) based on the proportionately set speed controller and integral gain1 values set at CON-21 (ASR-SL P Gain1) and CON-22 (ASR-SL I Gain1).</p>   |

| Code   | Description   |
|--|---|
|  | <p>Therefore, P-gain2 and I-gain2 values of less than 100% result in decreased responsiveness when the inverter is operating above medium speed.* For example, if both P-gain1 and P-gain2 are set to 50%, the actual P-gain2 value is 25% of the reference. Likewise, if I-gain1 is set to 100 ms and I-gain2 is set to 50%, the resulting I-gain 2 value becomes 200 ms. By default, the speed controller gain values are set according to the motor parameters and acceleration and deceleration times.</p> <p>*Medium speed: A speed range that is approximately 50% of the base frequency.</p>   |
| <p>CON-26 Observer Gain1,<br/>CON-27 Observer Gain2,<br/>CON-28 Observer Gain3</p> | <p>These codes are visible only when CON-20 is set to “1 (yes)”. The observer gain values may be adjusted by system engineers only. Sensorless-2 vector control mode requires the observers to estimate the motor’s stator current and rotor magnetic flux. While observer gain1 (CON-26) is applied when the inverter operates at low to medium speeds, observer gain2 (CON-27) is applied when the inverter operates at medium to high speeds. Observer gain3 (CON-28) is applied in torque control mode.</p>   |
| <p>CON-29 S-Est P Gain1,<br/>CON-30 S-Est I Gain1</p>                              | <p>Sets the speed estimator gain values for sensorless-2 vector control mode. Increase or decrease the speed estimator P-gain or I-gain by small increments if the displayed speed does not match the speed reference. You can also adjust the speed estimator gain values if the motor vibrates severely, or a high current ripple occurs at power on. Decrease the speed estimator P-gain or I-gain gradually to reduce the vibration or current ripple. By default, the speed estimator gains are set according to the default motor parameters and acceleration and deceleration times.</p>   |
| <p>CON-31 S-Est P Gain2,<br/>CON-32 S-Est I Gain2</p>                              | <p>These codes are visible only when CON-20 is set to “1 (yes)”. You can set the speed estimator gains to a frequency higher than the medium speed* in sensorless-2 vector control mode. CON-31 and CON-32 are set as percentage values of low-speed gain values set at CON-29 and CON-30. For example, if CON-29 S-Est P-Gain1 is 300 and CON-31 S-Est P-Gain2 is 40.0%, the speed estimator P-gain at higher than the actual medium speed is 120. By default, the speed estimator gains are set according to the default motor parameters and acceleration and deceleration times.</p> <p>*Medium speed: A speed range that is approximately 50% of the base frequency.</p> |
| <p>CON-34 SL2 OVM Perc</p>   | <p>When the output voltage/input voltage ratio is below 100% (when the output voltage is not over modulated), the output voltage bears linear characteristics to the input voltage. In sensorless-2 control mode, you can set CON-34 (SL2 OVM Perc) to define a voltage range to be limited in the over modulated zone. By default, CON-34 (SL2 OVM Perc) is set as 120%. However, for a high-impact load where the load often exceeds the torque limit, such as a</p>  |

| Code                                    | Description   |
|---|---|
|   | <p>press load, you can increase the limit value to avoid frequent over current fault trips.</p> <p>Also, in areas where the power supply is unstable, the input voltage tends to be lower than the rated input voltage, which results in more frequent overcurrent (OC1) fault trips with aforementioned high-impact load applications. If this is the case, you can set CON-34 (SL2 OVM Perc) as 140–150% to avoid frequent fault trips.</p>   |
| CON-48 ACR P-Gain,<br>CON-49 ACR I Gain | Sets the current PI controller P-gain and I-gain values.  |
| DRV-10 Torque Control                   | <p>Selects the speed control and torque control modes. If you set DRV-10 (Torque control) to “1 (Yes)”, the operation switches to torque control mode. Refer to <a href="#">8.14 Torque Control</a> on page <a href="#">236</a> for details.</p> <p><b>⚠ Caution</b></p> <ul style="list-style-type: none"> <li>• Torque control is not available during low-speed regeneration and low-speed operation under a light load. Select vector control mode instead.</li> <li>• When the inverter is operated in torque control mode, do not switch between forward and reverse rotations. Overcurrent or Rx deceleration fault trips may occur.</li> <li>• When the inverter is operated in sensorless vector control mode, enable accelerating speed search by setting the CON-71 (Speed search) bits to “0001,” if the inverter is expected to start or restart while the motor is free-running.</li> </ul> |

### ⚠ Caution

In sensorless-2 control mode, the motor may overheat or the system may become unstable if the gain values are not properly set.

### Note

Sensorless-2 vector control mode is greatly affected by the motor and load characteristics. Therefore, it is sometimes necessary to adjust the controller gain values.

When a sensorless-2 vector control is operated in speed mode [DRV-10 (torque control) is set to “0 (No)”. If the operation is unstable at extremely low speeds (below 2–3 Hz), or if the speed bounces during startup, increase the CON-22 (ASR-SL I Gain1) value to 200% of the default value. With a regenerative load, motor torque ripples may occur frequently. In this case, decrease the CON-21 (ASR-SL P Gain1) value to 50% of the default value. If this does not solve the problem, increase the CON-21 (ASR-SL P Gain1) value back to the default, and decrease the CON-30 (S-Est I Gain1) value to 50% of the default value.

## 8.13 Vector Control Mode Operation



With an optional encoder module installed to the inverter, vector control mode provides highly precise operation abilities.

Similar to sensorless-1 and sensorless-2 vector control modes, vector control mode requires motor parameter values for operation. Before operating the inverter in sensorless-2 mode, run auto tuning first.

| Group | Code | Name                                 | LCD Display    | Parameter Setting |             | Unit |
|-------|------|--------------------------------------|----------------|-------------------|-------------|------|
| DRV   | 09   | Control mode                         | Control Mode   | 5                 | Vector      | -    |
|       | 21   | Speed unit selection                 | Hz / rpm Sel   | 1                 | Rpm Display | -    |
| BAS   | 20   | Auto tuning                          | Auto Tuning    | 1                 | All         | -    |
| CON   | 09   | Initial excitation time              | PreExTime      | -                 | 1.0         | sec  |
|       | 10   | Initial excitation power supply      | Flux Force     | -                 | 100.0       | %    |
|       | 11   | Continued operation duration         | Hold Time      | -                 | 1.0         | sec  |
|       | 12   | Speed controller proportional gain 1 | ASR P Gain 1   | -                 | 50.0        | %    |
|       | 13   | Speed controller integral gain 1     | ASR I Gain 1   | -                 | 300         | ms   |
|       | 15   | Speed controller proportional gain 2 | ASR P Gain 2   | -                 | 50.0        | %    |
|       | 16   | Speed controller integral gain 2     | ASR I Gain 2   | -                 | 300         | ms   |
|       | 18   | Gain exchange frequency              | Gain Sw Freq   | -                 | 0.00        | Hz   |
|       | 19   | Gain exchange time                   | Gain Sw Delay  | -                 | 0.10        | sec  |
|       | 51   | Speed controller reference filter    | ASR Ref LPF    | -                 | 0           | ms   |
|       | 52   | Torque controller output filter      | Torque Out LPF | -                 | 0           | ms   |
|       | 53   | Torque limit setting options         | Torque Lmt Src | 0                 | Keypad-1    | -    |
|       | 54   | Forward offsetting torque limit      | FWD +Trq Lmt   | -                 | 180         | %    |
|       | 55   | Forward regenerative torque limit    | FWD -Trq Lmt   | -                 | 180         | %    |
|       | 56   | Reverse offsetting torque limit      | REV +Trq Lmt   | -                 | 180         | %    |
|       | 57   | Reverse regenerative torque limit    | REV -Trq Lmt   | -                 | 180         | %    |
|       | 58   | Torque bias setting options          | Trq Bias Src   | 0                 | Keypad-1    | -    |
|       | 59   | Torque bias                          | Torque Bias    | -                 | 0.0         | %    |
|       | 60   | Torque bias                          | Trq BiasFF     | -                 | 0.0         | %    |

| Group | Code  | Name                         | LCD Display | Parameter Setting | Unit |
|-------|-------|------------------------------|-------------|-------------------|------|
|       |       | compensation                 |             |                   |      |
| IN    | 65–75 | PX terminal function setting | Px Define   | 36 Asr Gain 2     | -    |
|       | 65–75 | PX terminal function setting | Px Define   | 37 ASR P/PI       | -    |

### ⚠ Caution

- For vector control mode operation, the motor-rated capacity must match the inverter's rated capacity. If the inverter capacity is too large for the installed motor, run the motor in V/F mode.
- Vector control mode does not support multiple motor control (MMC) features. Do not connect multiple motors to one inverter that is operating in vector control mode.

### Vector Control Mode–Details

| Code  | Description  |         |             |   |                    |   |                    |   |                       |
|---|--|---------|-------------|---|--------------------|---|--------------------|---|-----------------------|
| DRV-14 Motor Capacity, BAS-11 Pole Number, BAS-12 Rated Slip, BAS-13 Rated Curr, BAS-15 Rated Volt, BAS-16 Efficiency | Motor parameter information is required for vector control mode operation. Check the motor's rating plate for the motor capacity and other performance-related information, set the relevant parameters, and then run auto tuning at BAS-20.   |         |             |   |                    |   |                    |   |                       |
| APO-01 Enc Opt Mode   | Sets the encoder option mode to "1 (feedback)".  |         |             |   |                    |   |                    |   |                       |
| APO-04 Enc Type Sel   | Sets the encoder's signal delivery options. Refer to the instruction manual supplied with the encoder and select one of the following options:<br>0: Line Driver / 1: Totem or Com / 2: Open Collect   |         |             |   |                    |   |                    |   |                       |
| APO-05 Enc Pulse Sel  | Sets the encoder output pulse options. <table border="1" data-bbox="440 1219 1222 1340"> <thead> <tr> <th>Setting</th> <th>Description</th> </tr> </thead> <tbody> <tr> <td>0</td> <td>(A+B) Fx operation</td> </tr> <tr> <td>1</td> <td>(A+B) Rx operation</td> </tr> <tr> <td>2</td> <td>A Frequency reference</td> </tr> </tbody> </table>  | Setting | Description | 0 | (A+B) Fx operation | 1 | (A+B) Rx operation | 2 | A Frequency reference |
| Setting   | Description  |         |             |   |                    |   |                    |   |                       |
| 0   | (A+B) Fx operation   |         |             |   |                    |   |                    |   |                       |
| 1   | (A+B) Rx operation   |         |             |   |                    |   |                    |   |                       |
| 2   | A Frequency reference  |         |             |   |                    |   |                    |   |                       |
| APO-06 Enc Pulse Num  | Sets the number of pulses per rotation.  |         |             |   |                    |   |                    |   |                       |
| APO-08 Enc Monitor  | Converts the encoder output into motor rotation and displays in Hz or rpm units.   |         |             |   |                    |   |                    |   |                       |
| BAS-20 Auto Tuning  | <p><b>To test the encoder:</b><br/>Sets the auto tuning type to "3 (Enc Test)" to check the encoder connection. The inverter operates in the Fx direction and accelerates to 20 Hz until it decelerates to 0 Hz and continues operating in the Rx direction, accelerating to 20 Hz.<br/>The BAS-20 parameter value is automatically changed to "None" if a connection error is not detected.<br/>The "Enc reverse" message is displayed if the encoder connection is not</p> |         |             |   |                    |   |                    |   |                       |

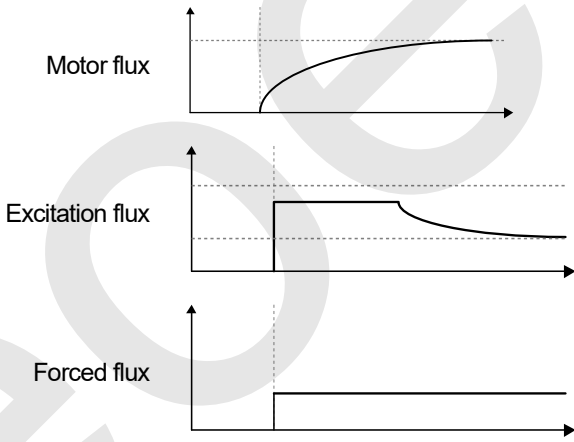
| Code                                      | Description   |
|---|---|
|   | <p>correct. If this happens, you can change the APO-05 (ENC Pulse Sel) parameter setting to match the actual direction, or swap the two encoder cables that are connected to the motor.</p> <p><b>To perform rotating auto tuning</b>, separate the load from the motor axis, and set BAS-20 to "1 (ALL)". The motor stator resistance (<math>R_s</math>), leakage inductance (<math>L_{\sigma}</math>), stator inductance (<math>L_s</math>), no-load current (Noload Curr) and rotor time constant (<math>T_r</math>) are saved in BAS-21, BAS-22, BAS-23, BAS-14, and BAS-24 respectively.</p> |
| CON-09 PreExTime                          | Sets the initial excitation time. Operation begins after the motor is excited to the rated speed.   |
| CON-10 Flux Force                         | <p>Flux force may be used to reduce the initial excitation time. The motor flux increases based on a time constant. To reduce the time to reach the rated flux, you can supply a flux larger than the rating at first, and then reduce the amount of flux when the motor is excited close to the rated flux.</p>   |
| CON-12 ASR P Gain1,<br>CON-13 ASR I Gain1 | Sets the speed controller proportional and integral gain values. Increasing the P-gain increases responsiveness and torque output, while decreasing the I-gain increases responsiveness. However, note that excessively high P-gain or low I-gain settings may result in motor speed oscillation.   |
| CON-15 ASR P Gain2,<br>CON-16 ASR I Gain2 | These codes are used to configure the gains that are applied based on the load characteristics and motor speed. The switching of gain values is performed based on the switching frequency set at CON-18 and the switching time set at CON-19.  |
| CON-51 ASR Ref LPF                        | Sets the filter time constant that is used in vector speed mode for the speed controller.   |
| CON-52 Torque Out LPF                     | Sets the filter time constant that can be used in vector speed or vector torque mode. In vector speed mode, it is applied to the speed controller. In vector torque mode, it is applied to the torque reference.  |

| Code   | Description   |   |  |
|--|---|---|--|
| CON-48 ACR P-Gain,<br>CON-49 ACR I Gain  | Sets the P-and I-gain values for the current PI controller. These gains are used in sensorless speed/torque modes and vector speed/torque modes.  |   |  |
| IN-65–75 Px Define   | Sets the multi-function terminals to control the gains and controllers.   |   |  |
|  | Setting   | Description   |  |
|  | 36  | ASR Gain2   | When the terminal is on, gain switching takes place after the time set at CON-19 has passed. |
|  | 37  | ASR P/PI  | When the terminal is on, the integral controller stops operating.                            |
| CON-53 Torque Lmt Src  | Sets the input source for the torque limit function. The torque limit function is used to limit the output to adjust the torque reference.  |   |  |
|  | Setting   | Description   |  |
|  | 0   | Keypad-1  | Sets the torque limit using the keypad (up to 200% of the motor rated torque).               |
|  | 1   | Keypad-2  |  |
|  | 2   | V1  | Sets the torque limit using the analog terminals.  |
| 3  | I1  |   |  |
| 6  | Int 485   | Sets the torque limit using the built-in 485 communication device.  |  |
| IN-02 Torque at 100%   | Sets the torque limit values for the analog input. If CON-53 is set to “2 (V1)” and IN-02 is set to “200%”, the torque limit becomes 200% when 10 V input is supplied to V1.*<br>(*Applies only if all V1 function parameters use default setting values.)<br>When any device other than the keypad is selected as the torque limit input source, set CNF-21–23 to “21 (Torque Limit)”. |   |  |
| CON-33 FWD +Trq Lmt<br>CON-34 FWD –Trq Lmt<br>CON-35 REV +Trq Lmt<br>CON-36 REV –Trq Lmt | Sets the direction of the torque limit when CON-53 is set to “0 (Keypad-1)” or “1 (Keypad-2)”. The torque limit can be set up to 200% of the motor rated torque.  |   |  |
|  | Setting   | Description   |  |
|  | FWD +Trq Lmt  | Sets the torque limit for FX motoring operation.  |  |
|  | FWD –Trq Lmt  | Sets the torque limit for FX regenerating operation.  |  |
|  | REV +Trq Lmt  | Sets the torque limit for RX motoring operation.  |  |
| REV –Trq Lmt   | Sets the torque limit for RX regenerating operation.  |   |  |
| CON-58 Trq Bias Src  | Selects the input source for the offset setting to be added to the torque reference.  |   |  |
|  | Setting   | Description   |  |
|  | 0   | Keypad-1  | Sets the torque bias using the keypad (-120% – +120%, set at CON-59).                        |
|  | 1   | Keypad-2  |  |
| 2  | V1  | Sets the torque bias using the analog terminals. (-120% – +120%, set at CON-59).<br>The setting can be viewed in monitor mode. Set CFG-06–08 to “21 (Torque bias)”. |  |
| 3  | I1  |   |  |
| CON-59 Torque Bias   | Sets the torque bias value between -120%– +120%.  |   |  |
| IN-65–75 Px Define   | Sets one of the multi-function terminals to “48 (Trq Bias)”. Torque bias input via the keypad or analog input is applied only when this multi-function terminal is on.  |   |  |

| Code              | Description   |
|-------------------|---|
| CON-60 Trq BiasFF | Sets the compensation volume to add to the bias to make up for the loss caused by motor rotation. Negative (-) values diminish the torque bias. |
| CON-11 Hold Time  | <p>When a run command stops, the inverter holds the zero speed output for the set time before the motor decelerates to a complete stop.</p>     |

## 8.14 Torque Control

You can use torque control to operate the inverter to produce a certain amount of torque as indicated by the torque reference. In torque control mode, the motor speed is decided by the amount of load because a motor can run at a constant speed when the output torque and torque load are equal. The motor speed increases when the output torque becomes greater than the torque load. You can set a speed limit to maintain the motor speed within a certain range. Note that torque control is not available during the speed control operations.

| Group | Code  | Name  | LCD Display    | Parameter Setting |              | Unit |
|-------|-------|---|----------------|-------------------|--------------|------|
| DRV   | 02    | Torque command                                | Cmd Torque     | -                 | 0.0          | %    |
|       | 08    | Torque reference source                       | Trq Ref Src    | 0                 | Keypad-1     | -    |
|       | 09    | Control mode                                  | Control Mode   | 5                 | Vector       | -    |
|       | 10    | Torque control                                | Torque Control | 1                 | Yes          | -    |
| BAS   | 20    | Auto tuning                                   | Auto Tuning    | 1                 | Yes          | -    |
| CON   | 35    | SL2 L-ExcitLmt                                | SL2 L-ExcitLmt | -                 | 10           | %    |
|       | 62    | Speed limit setting options                   | Speed Lmt Src  | 0                 | Keypad-1     | -    |
|       | 63    | Forward speed limit                           | FWD Speed Lmt  | -                 | 60.00        | Hz   |
|       | 64    | Reverse speed limit                           | REV Speed Lmt  | -                 | 60.00        | Hz   |
|       | 65    | Speed limit operation gain                    | Speed Lmt Gain | -                 | 500          | %    |
| IN    | 65–75 | PX terminal function setting                  | Px Define      | 35                | Speed/Torque | -    |
| OUT   | 31–33 | Multi-function relay, Multi-function output 1 | Relay x or Q1  | 27                | Torque Dect  | -    |
|       | 59    | Detected torque amount                        | TD Level       | -                 | 100          | %    |
|       | 60    | Detected torque width                         | TD Band        | -                 | 5.0          | %    |

### Note

- Basic parameters for inverter operation must be correctly set before you can operate the inverter in torque control mode.
- Torque control is not available during low speed regeneration and light load operation. Operate the inverter in vector control mode instead.
- Do not switch between Fx and Rx operations while the inverter is operating in torque control mode. An overcurrent or reverse deceleration fault trip may occur as a result.

### Torque Control–Details

| Code  | Description  |             |             |   |          |   |          |   |    |   |    |   |        |
|---|--|-------------|-------------|---|----------|---|----------|---|----|---|----|---|--------|
| DRV-08 Trq Ref Src  | Select the input source for the torque reference.  |             |             |   |          |   |          |   |    |   |    |   |        |
|   | <table border="1"> <thead> <tr> <th>Setting</th> <th>Description</th> </tr> </thead> <tbody> <tr> <td>0</td> <td>Keypad-1</td> </tr> <tr> <td>1</td> <td>Keypad-2</td> </tr> <tr> <td>2</td> <td>V1</td> </tr> <tr> <td>3</td> <td>I1</td> </tr> <tr> <td>6</td> <td>Int485</td> </tr> </tbody> </table> | Setting     | Description | 0 | Keypad-1 | 1 | Keypad-2 | 2 | V1 | 3 | I1 | 6 | Int485 |
|   | Setting  | Description |             |   |          |   |          |   |    |   |    |   |        |
|   | 0  | Keypad-1    |             |   |          |   |          |   |    |   |    |   |        |
|   | 1  | Keypad-2    |             |   |          |   |          |   |    |   |    |   |        |
|   | 2  | V1          |             |   |          |   |          |   |    |   |    |   |        |
| 3   | I1   |             |             |   |          |   |          |   |    |   |    |   |        |
| 6   | Int485   |             |             |   |          |   |          |   |    |   |    |   |        |
| Sets the torque reference using the keypad (up to 180% of rated motor torque, set at CON-02).   |  |             |             |   |          |   |          |   |    |   |    |   |        |
| Sets the torque reference using the analog terminals. The torque reference changes based on the set value at IN-02 (Torque at 100%). For example, if IN-02 is set to 200%, the torque reference becomes 200% when 20 mA current is supplied. The setting can be viewed in monitor mode. Set CFG-06–08 to “19 (Torque Ref)”. |  |             |             |   |          |   |          |   |    |   |    |   |        |
| Sets the torque reference using the built-in RS485 communication device.  |  |             |             |   |          |   |          |   |    |   |    |   |        |
| CON-02 CMD Torque   | Sets the torque reference for keypad input.  |             |             |   |          |   |          |   |    |   |    |   |        |
| IN-02 Torque at 100%  | Sets the torque reference for analog terminal input.   |             |             |   |          |   |          |   |    |   |    |   |        |
| CON-35 SL2 L-ExcitLmt   | This is the ratio to improve the operating characteristics in the low torque/low speed range by lowering the magnetic flux current. However, if the value is set too low, stable sensorless control may not be possible.   |             |             |   |          |   |          |   |    |   |    |   |        |
| CON-62 Speed Lmt Src  | Select the input source for the speed limit.   |             |             |   |          |   |          |   |    |   |    |   |        |
|   | <table border="1"> <thead> <tr> <th>Setting</th> <th>Description</th> </tr> </thead> <tbody> <tr> <td>0</td> <td>Keypad-1</td> </tr> <tr> <td>1</td> <td>Keypad-2</td> </tr> <tr> <td>2</td> <td>V1</td> </tr> <tr> <td>3</td> <td>I1</td> </tr> <tr> <td>6</td> <td>Int485</td> </tr> </tbody> </table> | Setting     | Description | 0 | Keypad-1 | 1 | Keypad-2 | 2 | V1 | 3 | I1 | 6 | Int485 |
|   | Setting  | Description |             |   |          |   |          |   |    |   |    |   |        |
|   | 0  | Keypad-1    |             |   |          |   |          |   |    |   |    |   |        |
|   | 1  | Keypad-2    |             |   |          |   |          |   |    |   |    |   |        |
|   | 2  | V1          |             |   |          |   |          |   |    |   |    |   |        |
| 3   | I1   |             |             |   |          |   |          |   |    |   |    |   |        |
| 6   | Int485   |             |             |   |          |   |          |   |    |   |    |   |        |
| Sets the speed limit using the keypad (CON-63 FWD Speed Lmt / CON-64 REV Speed Lmt).  |  |             |             |   |          |   |          |   |    |   |    |   |        |
| Set the torque reference using the analog terminals, in the same manner as setting a frequency reference.   |  |             |             |   |          |   |          |   |    |   |    |   |        |
| The setting can be viewed in monitor mode. Set CNF-21–23 to “23 (Speed Limit)”.   |  |             |             |   |          |   |          |   |    |   |    |   |        |
| CON-65 Speed Lmt Gain   | Set the torque reference decrement rate between 100%–5000% for when the speed limit is exceeded.   |             |             |   |          |   |          |   |    |   |    |   |        |
| IN-65–75 Px Define  | Sets one of the multi-function inputs to “35 (Speed/Torque)”. Switching between torque control mode and speed (vector) control mode takes place when the terminal  |             |             |   |          |   |          |   |    |   |    |   |        |

| Code | Description |
|------|-------------|
|      | is on.      |

## 8.15 Droop Control

Droop control is used to balance the load when operating multiple motors for a single load, or to prevent speed controller saturation in vector control mode.

| Group | Code | Name                   | LCD Display     | Parameter Setting |       | Unit |
|-------|------|------------------------|-----------------|-------------------|-------|------|
| CON   | 66   | Droop operation amount | Droop Perc      | -                 | 0.0   | %    |
|       | 67   | Droop start torque     | Droop St Torque | -                 | 100.0 | %    |

### Droop Control—Details

| Code                      | Description  |
|---------------------------|--|
| CON-66 Droop Perc         | Sets the percentage rate for the droop operation based on the rated torque.  |
| CON-67 Droop start torque | <p>Sets the torque to start droop operation. Based on the set value, the motor speed can be calculated as follows:</p> $\text{Droop speed} = \text{Maximum frequency} \times \text{DroopPerc} \times \frac{\text{Torque reference} - \text{DroopStTorque}}{100\% \text{ torque} - \text{DroopStTorque}}$ |

## 8.16 Speed / Torque Control Switching

Set one of the multi-function terminals to switch between speed and torque control modes. This function is only available in vector control mode.

| Group | Code  | Name   | LCD Display    | Parameter Setting |              | Unit |
|-------|-------|--|----------------|-------------------|--------------|------|
| CON   | 68    | Torque mode—speed mode switching acceleration time | SPD/TRQAcc T   | -                 | 20.0         | sec  |
|       | 69    | Torque mode—speed mode switching deceleration time | SPD/TRQDec T   | -                 | 30.0         | sec  |
| IN    | 65–75 | PX terminal setting option                         | Px Define      | 35                | Speed/Torque | -    |
| DRV   | 09    | Control mode                                       | Control Mode   | 5                 | Vector       | -    |
|       | 10    | Torque control                                     | Torque Control | 0                 | No           | -    |
| 1     |       |  |                | Yes               | -            |      |

Set a multi-function input Px to “35 (Speed/Torque)”.

If the terminal is on during a vector torque operation, where DRV-09 (Control Mode) is set to “5 (Vector)” and DRV-10 (Torque Control) is set to “1 (Yes)”, the operation switches from torque to speed mode based on the acceleration and deceleration times set at CON-68 (SPD/TRQAcc T) and CON-69 (SPD/TRQDec T).

If the terminal is on during a vector speed operation, where DRV-09 (Control Mode) is set to “5 (Vector)” and DRV-10 (Torque Control) is set to “0 (No)”, the operation switches from speed to torque mode.

## 8.17 Kinetic Energy Buffering

When the input power supply is disconnected, the inverter’s DC link voltage decreases, and a low voltage trip occurs, blocking the output. A kinetic energy buffering operation uses regenerative energy generated by the motor during the blackout to maintain the DC link voltage. This extends the time for a low voltage trip to occur after an instantaneous power interruption.

| Group | Code                                       | Name                                 | LCD Display   | Parameter Setting |              | Setting range | Unit |
|-------|--|--------------------------------------|---------------|-------------------|--------------|---------------|------|
| CON   | 77   | Kinetic energy buffering selection   | KEB Select    | 0                 | None         | 0–2           | -    |
|       |  |                                      |               | 1                 | KEB-1        |               |      |
|       |  |                                      |               | 2                 | KEB-2        |               |      |
|       | 78   | Kinetic energy buffering start level | KEB Start Lev | 130               |              | 110–200       | %    |
|       | 79   | Kinetic energy buffering stop level  | KEB Stop Lev  | 135               |              | 130–210       | %    |
|       | 86   | Kinetic energy buffering P-Gain      | KEB P Gain    | 1500              |              | 0–20000       | %    |
|       | 87   | Kinetic energy buffering I gain      | KEB I Gain    | 500               |              | 1–20000       | %    |
| 88    | Kinetic energy buffering slip gain         | KEB Slip Gain                        | 30.0          |                   | 0–2000.0     | %             |      |
| 89    | Kinetic energy buffering acceleration time | KEB Acc Time                         | 10.0          |                   | 0.0–600.0    | Sec           |      |
| IN    | 65–75                                      | PX terminal setting option           | Px Define     | 50                | KEB-1 Select | 0–51          |      |

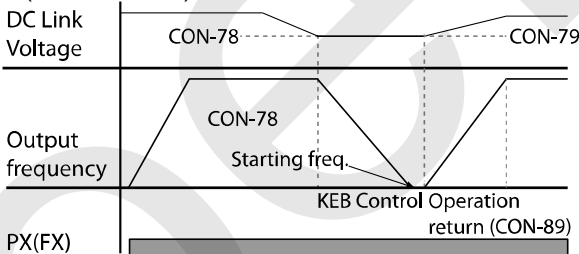
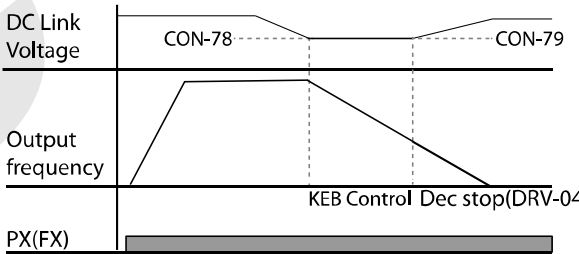
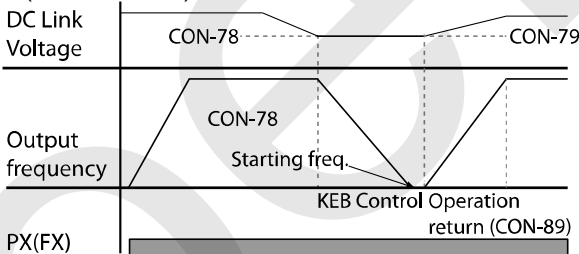
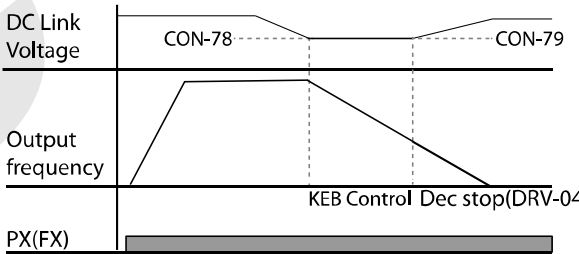
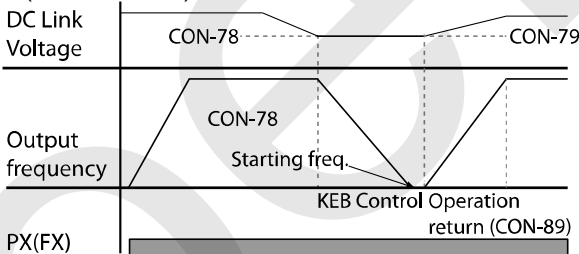
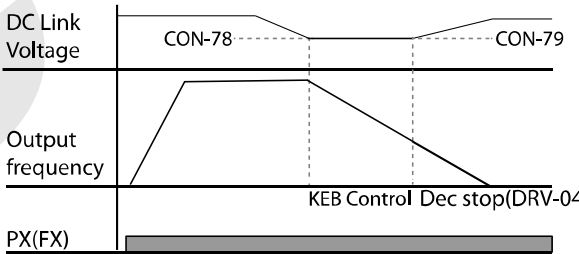

**Kinetic Energy Buffering Operation Setting Details**

| Code   | Description   |         |          |        |  |         |  |         |   |
|--|---|---------|----------|--------|--|---------|--|---------|---|
|  | <p>Select the kinetic energy buffering operation when the input power is disconnected.</p> <p><b>Note</b></p> <p>If a multi-function terminal is set to "50 (KEB-1 Select)", KEB operation is available via terminal input only. Set CON-77 to "0 (none)" in this case.</p>   |         |          |        |  |         |  |         |   |
|  | <table border="1"> <thead> <tr> <th>Setting</th> <th>Function</th> </tr> </thead> <tbody> <tr> <td>0 None</td> <td>General deceleration is carried out until a low voltage trip occurs.</td> </tr> <tr> <td>1 KEB-1</td> <td> <p>If input power failure occurs, the inverter output frequency is controlled and the regeneration energy from the motor is charged by the inverter. Normal operation is resumed when the power is supplied again, using the acceleration time set at CON-89 (KEB Acc Time).</p>  </td> </tr> <tr> <td>2 KEB-2</td> <td> <p>If input power failure occurs, the inverter output frequency is controlled and the regeneration energy from the motor is charged by the inverter. The motor decelerates and stops when the power is supplied again, using the deceleration time set at DRV-04 (Dec Time).</p>  </td> </tr> </tbody> </table> | Setting | Function | 0 None | General deceleration is carried out until a low voltage trip occurs. | 1 KEB-1 | <p>If input power failure occurs, the inverter output frequency is controlled and the regeneration energy from the motor is charged by the inverter. Normal operation is resumed when the power is supplied again, using the acceleration time set at CON-89 (KEB Acc Time).</p>  | 2 KEB-2 | <p>If input power failure occurs, the inverter output frequency is controlled and the regeneration energy from the motor is charged by the inverter. The motor decelerates and stops when the power is supplied again, using the deceleration time set at DRV-04 (Dec Time).</p>  |
| Setting  | Function  |         |          |        |  |         |  |         |   |
| 0 None   | General deceleration is carried out until a low voltage trip occurs.  |         |          |        |  |         |  |         |   |
| 1 KEB-1  | <p>If input power failure occurs, the inverter output frequency is controlled and the regeneration energy from the motor is charged by the inverter. Normal operation is resumed when the power is supplied again, using the acceleration time set at CON-89 (KEB Acc Time).</p>   |         |          |        |  |         |  |         |   |
| 2 KEB-2  | <p>If input power failure occurs, the inverter output frequency is controlled and the regeneration energy from the motor is charged by the inverter. The motor decelerates and stops when the power is supplied again, using the deceleration time set at DRV-04 (Dec Time).</p>    |         |          |        |  |         |  |         |   |
| CON-78<br>KEB Start Lev,<br>CON-79<br>KEB Stop Lev | Sets the start and stop points of the kinetic energy buffering operation. The set values must be based on the low voltage trip level at 100%, and the stop level (CON-79) must be set higher than the start level (CON-78).   |         |          |        |  |         |  |         |   |
| CON-86<br>KEB P Gain                               | Used to maintain the voltage during the kinetic energy buffering operation. It operates the inverter by modifying the set value to prevent malfunctions caused by low voltage after power interruptions.  |         |          |        |  |         |  |         |   |

| Code                    | Description   |
|-------------------------|---|
| CON-87<br>KEB I Gain    | Used to maintain the voltage during the kinetic energy buffering operation. Sets the gain value to maintain the operation until the frequency stops during the kinetic energy buffering operation.  |
| CON-88<br>KEB Slip Gain | Used to prevent malfunctions caused by low voltage from initial kinetic energy buffering occurring due to power interruptions.  |
| CON-89<br>KEB Acc Time  | Sets the acceleration time for the frequency reference when the inverter's operation becomes normal after the kinetic energy buffering operation.   |
| IN-65–75 Px Define      | <p>Sets a multi-function input Px to "50 (KEB-1 Select)". If the terminal is on during an operation, the inverter operates in KEB-1 mode. The inverter output frequency is controlled to the output level set at CON-78 and the regeneration energy from the motor is charged by the inverter. Normal operation is resumed when the power is supplied again, using the acceleration time set at CON-89 (KEB Acc Time). If the terminal is not on, KEB operation does not start when the input power failure occurs.</p> <p>If a multi-function terminal is set to "50 (KEB-1 Select)", KEB operation is available via terminal input only. Set CON-77 to "0 (none)" in this case.</p> <p>The diagram illustrates the interaction between three signals during a power interruption and recovery. The top signal, DC Link Voltage, shows a step-down during the power interruption. The middle signal, Output frequency, ramps down from its normal operating level to a lower 'KEB Control' level during the interruption and then ramps back up during the 'Operation return' phase. The bottom signal, PX (KEB-1 Select), is a pulse that is active during the KEB Control period, indicating that the inverter is in KEB-1 mode.</p> |

**⚠ Caution**

- Depending on the duration of instantaneous power interruptions and the amount of load inertia, a low voltage trip may occur even during a kinetic energy buffering operation.
- Motors may vibrate during kinetic energy buffering operation for some loads, except for variable torque loads (for example, fan or pump loads).

## 8.18 Energy Saving Operation

### 8.18.1 Manual Energy Saving Operation

If the inverter output current is lower than the current set at BAS-14 (Noload Curr), the output voltage must be reduced as low as the level set at ADV-51 (Energy Save). The voltage before the energy saving operation starts will become the base value of the percentage. The manual energy saving operation will not be carried out during acceleration and deceleration.

| Group | Code | Name                    | LCD Display | Parameter Setting |        | Setting Range |        | Unit |
|-------|------|-------------------------|-------------|-------------------|--------|---------------|--------|------|
| ADV   | 50   | Energy saving operation | E-Save Mode | 1                 | Manual | 0             | None   | -    |
|       |      |                         |             |                   |        | 1             | Manual |      |
|       |      |                         |             |                   |        | 2             | Auto   |      |
|       | 51   | Energy saving amount    | Energy Save | 30                |        | 0–30          | %      |      |

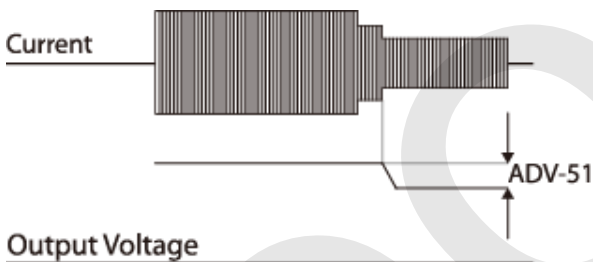

### 8.18.2 Automatic Energy Saving Operation

The inverter automatically finds the optimal energy saving point based on the motor rated current (BAS-13) and the no-load current (BAS-14).

| Group | Code | Name                    | LCD Display | Setting                      |      | Setting Range | Unit |
|-------|------|-------------------------|-------------|------------------------------|------|---------------|------|
| ADV   | 50   | Energy saving operation | E-Save Mode | 2                            | Auto | 0–2           | -    |
| BAS   | 13   | Motor-rated current     | Rated Curr  | Depends on inverter capacity |      | 1–1000        | A    |
|       | 14   | Motor no-load current   | Noload Curr | Depends on inverter capacity |      | 0.5–1000      | A    |

⚠ Caution

If the operation frequency is changed, or acceleration or deceleration is carried out during an energy saving operation, the actual acc/dec time may take longer than the set time due to the time required to return to general operations from the energy saving operation.







## 8.19 Speed Search Operation

Speed search operation is used to prevent fault trips that can occur when the inverter voltage output is disconnected and the motor is idling. Since this feature estimates the motor rotation speed based on the inverter output current, it does not give the exact speed.

| Group | Code                                  | Name                             | LCD Display    | Parameter Setting |                | Setting Range | Unit |
|-------|---------------------------------------|----------------------------------|----------------|-------------------|----------------|---------------|------|
| CON   | 70                                    | Speed search mode selection      | SS Mode        | 0                 | Flying Start-1 | -             | -    |
|       | 71                                    | Speed search operation selection | Speed Search   | 0000              |                | -             | bit  |
|       | 72                                    | Speed search reference current   | SS Sup-Current | Up to 75 kW       | 150            | 80–200        | %    |
|       |                                       |                                  |                | Over 75 kW        | 100            |               |      |
|       | 73                                    | Speed search proportional gain   | SS P-Gain      | 100               |                | 0–9999        | -    |
|       | 74                                    | Speed search integral gain       | SS I-Gain      | 200               |                | 0–9999        | -    |
| 75    | Output block time before speed search | SS Block Time                    | 1.0            |                   | 0–60           | sec           |      |
| OUT   | 31–32                                 | Multi-function relay 1–2         | Relay 1–2      | 19                | Speed Search   | -             | -    |
|       | 33                                    | Multi-function output 1          | Q1 Define      |                   |                |               |      |

### Speed Search Operation Setting Details

| Code             | Description   |   |
|------------------|---|---|
| CON-70 SS Mode   | Select a speed search type.                           |   |
|                  | Setting   | Function  |
|                  | 0 Flying Start-1                                      | The speed search is carried out as it controls the inverter output current during idling below the CON-72 (SS Sup-Current) parameter setting. If the direction of the idling motor and the direction of the operation command at restart are the same, a stable speed search function can be performed at about 10 Hz or lower. However, if the direction of the idling motor and the direction of the operation command at restart are different, the speed search does not produce a satisfactory result because the direction of idling cannot be established. |
| 1 Flying Start-2 | The speed search is carried out by the PI controller, |   |

| Code                       | Description   |   |                       |  |        |   |   |         |  |  |  |          |      |      |      |      |  |  |  |  |   |                                       |  |  |   |  |                                   |  |   |  |  |  |   |  |  |  |                     |
|----------------------------|---|---|-----------------------|--|--------|---|---|---------|--|--|--|----------|------|------|------|------|--|--|--|--|---|---------------------------------------|--|--|---|--|-----------------------------------|--|---|--|--|--|---|--|--|--|---------------------|
|                            | <p>which controls the ripple current generated by the counter electromotive force during no-load rotation. As this mode establishes the direction of the idling motor (forward/reverse), the speed search function is stable regardless of the direction of the idling motor and direction of the operation command. However, because the ripple current is used, which is generated by the counter electromotive force while idling (the counter electromotive force is proportional to the idle speed), the idle frequency is not determined accurately and re-acceleration may start from zero speed when the speed search is performed for the idling motor at a low speed (about 10 - 15 Hz, though it depends on motor characteristics).</p>  |   |                       |  |        |   |   |         |  |  |  |          |      |      |      |      |  |  |  |  |   |                                       |  |  |   |  |                                   |  |   |  |  |  |   |  |  |  |                     |
| <p>CON-71 Speed Search</p> | <p>Speed search can be selected from the following four options. If the top display segment is on, it is enabled (On). If the bottom segment is on, it is disabled (Off).</p> <table border="1" data-bbox="385 795 1237 929"> <thead> <tr> <th data-bbox="385 795 577 832">Item</th> <th data-bbox="577 795 906 832">Bit Setting On Status</th> <th data-bbox="906 795 1237 832">Bit Setting Off Status</th> </tr> </thead> <tbody> <tr> <td data-bbox="385 832 577 929">Keypad</td> <td data-bbox="577 832 906 929"></td> <td data-bbox="906 832 1237 929"></td> </tr> </tbody> </table> <p><b>Type and Functions of Speed Search Setting</b></p> <table border="1" data-bbox="385 1014 1237 1226"> <thead> <tr> <th colspan="4" data-bbox="385 1014 803 1051">Setting</th> <th data-bbox="803 1014 1237 1051">Function</th> </tr> <tr> <th data-bbox="385 1051 485 1087">bit4</th> <th data-bbox="485 1051 585 1087">bit3</th> <th data-bbox="585 1051 686 1087">bit2</th> <th data-bbox="686 1051 803 1087">bit1</th> <th data-bbox="803 1051 1237 1087"></th> </tr> </thead> <tbody> <tr> <td data-bbox="385 1087 485 1124"></td> <td data-bbox="485 1087 585 1124"></td> <td data-bbox="585 1087 686 1124"></td> <td data-bbox="686 1087 803 1124">✓</td> <td data-bbox="803 1087 1237 1124">Speed search for general acceleration</td> </tr> <tr> <td data-bbox="385 1124 485 1161"></td> <td data-bbox="485 1124 585 1161"></td> <td data-bbox="585 1124 686 1161">✓</td> <td data-bbox="686 1124 803 1161"></td> <td data-bbox="803 1124 1237 1161">Initialization after a fault trip</td> </tr> <tr> <td data-bbox="385 1161 485 1197"></td> <td data-bbox="485 1161 585 1197">✓</td> <td data-bbox="585 1161 686 1197"></td> <td data-bbox="686 1161 803 1197"></td> <td data-bbox="803 1161 1237 1197">Restart after instantaneous power interruption</td> </tr> <tr> <td data-bbox="385 1197 485 1226">✓</td> <td data-bbox="485 1197 585 1226"></td> <td data-bbox="585 1197 686 1226"></td> <td data-bbox="686 1197 803 1226"></td> <td data-bbox="803 1197 1237 1226">Start with power-on</td> </tr> </tbody> </table> <p><b>Speed search for general acceleration:</b> If bit 1 is set to “1” and the inverter operation command runs, acceleration starts with the speed search operation. When the motor is rotating under load, a fault trip may occur if the operation command is run for the inverter to provide voltage output. The speed search function prevents such fault trips from occurring.</p> <p><b>Initialization after a fault trip other than an LV trip:</b> If bit 2 is set to “1” and PRT-08 (RST Restart) is set to “1 (Yes)”, the speed search operation automatically accelerates the motor to the operation frequency used before the fault trip when the [STOP/RESET] key is pressed (or the terminal block input is on) after a fault trip.</p> <p><b>Automatic restart after an instantaneous power interruption:</b> If bit 3 is set to “1”, and if a low voltage trip occurs due to a power interruption but the power is restored before the internal power shuts down, the speed search operation accelerates the motor back to its frequency reference before the low voltage trip.</p> | Item  | Bit Setting On Status | Bit Setting Off Status                         | Keypad |  |  | Setting |  |  |  | Function | bit4 | bit3 | bit2 | bit1 |  |  |  |  | ✓ | Speed search for general acceleration |  |  | ✓ |  | Initialization after a fault trip |  | ✓ |  |  | Restart after instantaneous power interruption | ✓ |  |  |  | Start with power-on |
| Item                       | Bit Setting On Status   | Bit Setting Off Status  |                       |  |        |   |   |         |  |  |  |          |      |      |      |      |  |  |  |  |   |                                       |  |  |   |  |                                   |  |   |  |  |  |   |  |  |  |                     |
| Keypad                     |    |  |                       |  |        |   |   |         |  |  |  |          |      |      |      |      |  |  |  |  |   |                                       |  |  |   |  |                                   |  |   |  |  |  |   |  |  |  |                     |
| Setting                    |   |   |                       | Function                                       |        |   |   |         |  |  |  |          |      |      |      |      |  |  |  |  |   |                                       |  |  |   |  |                                   |  |   |  |  |  |   |  |  |  |                     |
| bit4                       | bit3  | bit2  | bit1                  |  |        |   |   |         |  |  |  |          |      |      |      |      |  |  |  |  |   |                                       |  |  |   |  |                                   |  |   |  |  |  |   |  |  |  |                     |
|                            |   |   | ✓                     | Speed search for general acceleration          |        |   |   |         |  |  |  |          |      |      |      |      |  |  |  |  |   |                                       |  |  |   |  |                                   |  |   |  |  |  |   |  |  |  |                     |
|                            |   | ✓   |                       | Initialization after a fault trip              |        |   |   |         |  |  |  |          |      |      |      |      |  |  |  |  |   |                                       |  |  |   |  |                                   |  |   |  |  |  |   |  |  |  |                     |
|                            | ✓   |   |                       | Restart after instantaneous power interruption |        |   |   |         |  |  |  |          |      |      |      |      |  |  |  |  |   |                                       |  |  |   |  |                                   |  |   |  |  |  |   |  |  |  |                     |
| ✓                          |   |   |                       | Start with power-on                            |        |   |   |         |  |  |  |          |      |      |      |      |  |  |  |  |   |                                       |  |  |   |  |                                   |  |   |  |  |  |   |  |  |  |                     |

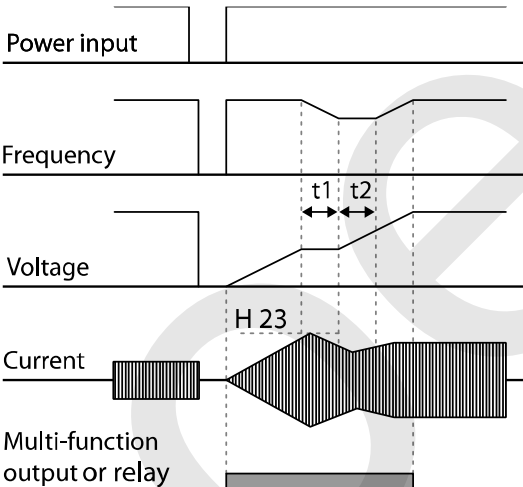
| Code                               | Description  |
|------------------------------------|--|
|                                    | <p>If an instantaneous power interruption occurs and the input power is disconnected, the inverter generates a low voltage trip and blocks the output. When the input power returns, the operation frequency before the low voltage trip and the voltage is increased by the inverter's inner PI controller.</p> <p>If the current increases above the value set at CON-72, the voltage stops increasing and the frequency decreases (t1 zone). If the current decreases below the value set at CON-72, the voltage increases again and the frequency stops decelerating (t2 zone). When the normal frequency and voltage are resumed, the speed search operation accelerates the motor back to its frequency reference before the fault trip.</p>  <p><b>Starting with power-on:</b> Set bit 4 to "1" and ADV-10 (Power-on Run) to "1 (Yes)". If inverter input power is supplied while the inverter operation command is on, the speed search operation will accelerate the motor up to the frequency reference.</p> |
| CON-72 SS Sup-Current              | The amount of current flow is controlled during speed search operation based on the motor's rated current. If CON-70 (SS mode) is set to "1 (Flying Start-2)", this code is not visible.   |
| CON-73 SS P-Gain, CON-74 SS I-Gain | The P/I gain of the speed search controller can be adjusted. If CON-70 (SS Mode) is set to "1"(Flying Start-2), different factory defaults based on motor capacity [at DRV-14 (Motor Capacity)] are used.  |
| CON-75 SS Block Time               | The block time parameter prevents overvoltage trips due to counter electromotive force by cutting off the inverter output for the set time before carrying out a speed search.   |

**Note**

- If operated within the rated output, the iS7 series inverter is designed to withstand instantaneous power interruptions of up to 15 ms and maintain normal operation [when 200–230 V AC input voltage

is supplied to 200 V class model types, and 380–460 V AC input voltage is supplied to 400 V class model types, and when the inverter is operating with static load current (CT load)].

- The DC voltage inside the inverter changes depending on the load. Low voltage fault trips may result if the power interruption lasts longer than 15 ms, or the output voltage exceeds the rated input voltage.

## 8.20 Auto Restart Settings

When inverter operation stops due to a fault and a fault trip is activated, the inverter automatically restarts based on the parameter settings.

| Group | Code                                  | Name                           | LCD Display    | Parameter Setting |          | Setting Range | Unit |
|-------|---------------------------------------|--------------------------------|----------------|-------------------|----------|---------------|------|
| PRT   | 08                                    | Select start at trip reset     | RST Restart    | 0                 | No       | -             | -    |
|       |                                       |                                |                | 1                 | Yes      |               |      |
|       | 09                                    | Auto restart count             | Retry Number   | 6                 |          | 0–10          | -    |
|       | 10                                    | Auto restart delay time        | Retry Delay    | 1.0               |          | 0.1–60.0      | sec  |
| CON   | 71                                    | Select speed search operation  | Speed Search   | -                 |          | 0000–1111     | bit  |
|       | 72                                    | Speed search startup current   | SS Sup-Current | Up to 75 kW       | 150      | 80–200        | %    |
|       |                                       |                                |                | Over 75 kW        | 100      |               |      |
|       | 73                                    | Speed search proportional gain | SS P-Gain      | 100               |          | 0–9999        |      |
|       | 74                                    | Speed search integral gain     | SS I-Gain      | 200               |          | 0–9999        |      |
| 75    | Output block time before speed search | SS Block Time                  | 1.0            |                   | 0.0–60.0 | sec           |      |

### Auto Restart Setting Details

| Code   | Description  |
|--|--|
| PRT-08<br>RST Restart                            | Set PRT-08 to “1 (Yes)” to enable reset restart.   |
| PRT-09<br>Retry Number,<br>PRT-10<br>Retry Delay | The number of available auto restarts can be set at PRT-09. If a fault trip occurs during an operation, the inverter restarts after the time set at PRT-10 (Retry Delay). At each restart, the inverter counts the number of tries and subtracts it from the number set at PRT-09 until the retry number count reaches 0. After an auto restart, if a fault trip does not occur within 60 sec, it will increase the restart count number. The maximum count number is limited by the number set at PRT-09. |



| Code | Description  |
|------|--|
|      | <p>If the inverter stops due to low voltage, an emergency stop, an inverter overheating, or a hardware malfunction, auto restart is not activated.</p> <p>At auto restart, the acceleration options are identical to those of the speed search operation. Codes CON-72–75 can be set based on the load. For the speed search function details, refer to <a href="#">8.19 Speed Search Operation</a> on page 244.</p> |

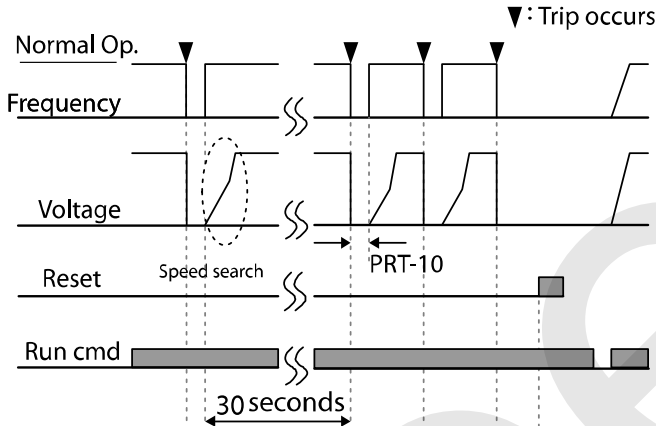

|                    |   |   |   |   |   |   |
|--------------------|---|---|---|---|---|---|
| Auto restart trial | 2 | 1 | 2 | 1 | 0 | 2 |
|--------------------|---|---|---|---|---|---|

[Example of auto restart with a setting of 2]

**⚠ Caution**

If the auto restart number is set, be careful when the inverter resets from a fault trip. The motor may automatically start to rotate.

## 8.21 Operational Noise Settings (Carrier Frequency Settings)

| Group | Code | Name              | LCD Display  | Parameter Setting | Setting Range                | Unit |
|-------|------|-------------------|--------------|-------------------|------------------------------|------|
| CON   | 04   | Carrier Frequency | Carrier Freq | 5.0               | 0.7–15.0                     | kHz  |
|       | 05   | Switching Mode    | PWM* Mode    | 0                 | Normal PWM / Low Leakage PWM | -    |

\* PWM: Pulse width modulation

**Operational Noise Setting Details**

| Code                              | Description  |            |                   |  |         |        |                |            |             |   |   |                   |   |   |                    |   |   |                |   |   |                                   |     |      |                |   |   |                          |   |   |
|-----------------------------------|--|------------|-------------------|--|---------|--------|----------------|------------|-------------|---|---|-------------------|---|---|--------------------|---|---|----------------|---|---|-----------------------------------|-----|------|----------------|---|---|--------------------------|---|---|
| CON-04<br>Carrier Freq            | Adjusts motor operational noise by changing carrier frequency settings. Power transistors (IGBT) in the inverter generate and supply high frequency switching voltage to the motor. The carrier frequency refers to the switching speed in this process. If the carrier frequency is set high, it reduces operational noise from the motor. If the carrier frequency is set low, it increases operational noise from the motor.  |            |                   |  |         |        |                |            |             |   |   |                   |   |   |                    |   |   |                |   |   |                                   |     |      |                |   |   |                          |   |   |
| CON-05 PWM Mode                   | <p>The heat loss and leakage current from the inverter can be reduced by changing the load rate option at CON-05 (PWM Mode). Selecting "1 (LowLeakage PWM)" reduces heat loss and leakage current, compared to when "0 (Normal PWM)" is selected. However, it increases the motor noise. Low leakage PWM uses a two-phase PWM modulation mode, which helps minimize degradation and reduces switching loss by approximately 30%.</p> <table border="1"> <thead> <tr> <th rowspan="3">Item</th> <th colspan="2">Carrier Frequency</th> </tr> <tr> <th>0.7 kHz</th> <th>15 kHz</th> </tr> <tr> <th>LowLeakage PWM</th> <th>Normal PWM</th> </tr> </thead> <tbody> <tr> <td>Motor noise</td> <td>↑</td> <td>↓</td> </tr> <tr> <td>Motor temperature</td> <td>↑</td> <td>↓</td> </tr> <tr> <td>Inverter heat Loss</td> <td>↓</td> <td>↑</td> </tr> <tr> <td>High frequency</td> <td>↑</td> <td>↓</td> </tr> <tr> <td>Inverter output current wave form</td> <td>Bad</td> <td>Good</td> </tr> <tr> <td>Inverter noise</td> <td>↓</td> <td>↑</td> </tr> <tr> <td>Inverter leakage current</td> <td>↓</td> <td>↑</td> </tr> </tbody> </table> | Item       | Carrier Frequency |  | 0.7 kHz | 15 kHz | LowLeakage PWM | Normal PWM | Motor noise | ↑ | ↓ | Motor temperature | ↑ | ↓ | Inverter heat Loss | ↓ | ↑ | High frequency | ↑ | ↓ | Inverter output current wave form | Bad | Good | Inverter noise | ↓ | ↑ | Inverter leakage current | ↓ | ↑ |
| Item                              | Carrier Frequency  |            |                   |  |         |        |                |            |             |   |   |                   |   |   |                    |   |   |                |   |   |                                   |     |      |                |   |   |                          |   |   |
|                                   | 0.7 kHz  |            | 15 kHz            |  |         |        |                |            |             |   |   |                   |   |   |                    |   |   |                |   |   |                                   |     |      |                |   |   |                          |   |   |
|                                   | LowLeakage PWM   | Normal PWM |                   |  |         |        |                |            |             |   |   |                   |   |   |                    |   |   |                |   |   |                                   |     |      |                |   |   |                          |   |   |
| Motor noise                       | ↑  | ↓          |                   |  |         |        |                |            |             |   |   |                   |   |   |                    |   |   |                |   |   |                                   |     |      |                |   |   |                          |   |   |
| Motor temperature                 | ↑  | ↓          |                   |  |         |        |                |            |             |   |   |                   |   |   |                    |   |   |                |   |   |                                   |     |      |                |   |   |                          |   |   |
| Inverter heat Loss                | ↓  | ↑          |                   |  |         |        |                |            |             |   |   |                   |   |   |                    |   |   |                |   |   |                                   |     |      |                |   |   |                          |   |   |
| High frequency                    | ↑  | ↓          |                   |  |         |        |                |            |             |   |   |                   |   |   |                    |   |   |                |   |   |                                   |     |      |                |   |   |                          |   |   |
| Inverter output current wave form | Bad  | Good       |                   |  |         |        |                |            |             |   |   |                   |   |   |                    |   |   |                |   |   |                                   |     |      |                |   |   |                          |   |   |
| Inverter noise                    | ↓  | ↑          |                   |  |         |        |                |            |             |   |   |                   |   |   |                    |   |   |                |   |   |                                   |     |      |                |   |   |                          |   |   |
| Inverter leakage current          | ↓  | ↑          |                   |  |         |        |                |            |             |   |   |                   |   |   |                    |   |   |                |   |   |                                   |     |      |                |   |   |                          |   |   |

**⚠ Caution**

- The factory default carrier frequency for 90–160 kW model types is **3 kHz**. The figure in the red box (D: 5.0) is a factory default carrier frequency for models types up to 75 kW, provided for your reference only.

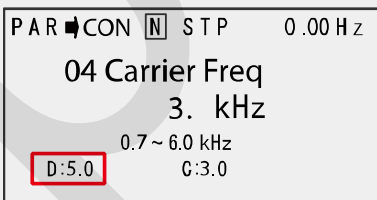

- Since low carrier frequencies can transmit a much higher frequency than the capacity of the output current, an increase in motor loss will occur. Some motors may stall due to increased high

frequency current and lack of torque may cause the inverter to stop.

## Note

- **Factory default carrier frequency by model types**

|                     |                     |                    |                    |                    |
|---------------------|---------------------|--------------------|--------------------|--------------------|
| 0.75–22 kW          | 30–45 kW            | 55–75 kW           | 90–110 kW          | 132–160 kW         |
| 5 kHz (15 kHz max.) | 5 kHz (10 kHz max.) | 5 kHz (7 kHz max.) | 3 kHz (6 kHz max.) | 3 kHz (5 kHz max.) |

- **iS7 Series Inverter Derating Standard (Derating):** The overload rate represents an acceptable load amount that exceeds the rated load, and is expressed as a ratio based on the rated load and the duration. The overload capacity on the iS7 series inverter is 110%/1 min for normal loads.
- The current rating differs by load types, and it also has an ambient temperature limit.
- **Current derating for ambient temperature at variable torque (VT) load operation:**

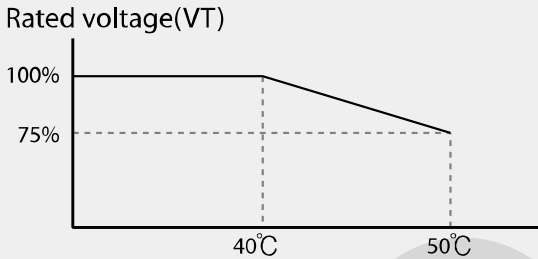

- **Current derating table by ambient temperature and carrier frequency:**

| Inverter Capacity |                     | 0.75–7.5kW | 11–22kW | 30–75kW |
|-------------------|---------------------|------------|---------|---------|
| CT Load           | Normal Temp. (25°C) | 10 kHz     | 10 kHz  | 5 kHz   |
|                   | High Temp. (40°C)   | 7 kHz      | 7 kHz   | 4 kHz   |
|                   | High Temp. (50°C)   | 5 kHz      | 5 kHz   | 4 kHz   |
| VT Load           | Normal Temp. (25°C) | 7 kHz      | 7 kHz   | 3 kHz   |
|                   | High Temp. (40°C)   | 2 kHz      | 2 kHz   | 2 kHz   |

## 8.22 2nd Motor Operation

The 2<sup>nd</sup> motor operation is used when a single inverter switch operates two motors. Using the 2<sup>nd</sup> motor operation, a parameter for the second motor is set. The second motor operates when a multi-function terminal input defined as a second motor function is turned on.

| Group | Code  | Name                        | LCD Display                             | Parameter Setting |           | Setting Range | Unit |
|-------|-------|-----------------------------|---|-------------------|-----------|---------------|------|
| IN    | 65–75 | Px terminal configuration   | Px Define(Px: P1–P8 [optional: P9–P11]) | 26                | 2nd Motor | -             | -    |
| M2    | 04    | 2nd motor acceleration time | M2-Acc Time                             | -                 | 5.0       | 0–600         | sec  |

### 2<sup>nd</sup> Motor Operation Setting Details

| Code               | Description  |
|--------------------|--|
| IN-65–75 Px Define | <p>Set one of the multi-function input terminals (P1–P11) to “26 (2nd Motor)” to display the M2 (2nd motor group) group. An input signal sent to a multi-function terminal set as the second motor will operate the motor according to the code settings listed below. However, if the inverter is in operation, input signals to the multi-function terminals will not read as a second motor parameter.</p> <ul style="list-style-type: none"> <li>You can set the 2nd motor control mode at M2-08 (M2-Ctrl Mode). V/F PG and Vector control modes are not supported with the 2nd motor operation.</li> <li>PRT-50 (Stall Prevent) must be set first, before M2-28 (M2-Stall Lev) settings can be used.</li> <li>PRT-40 (ETH Trip Sel) must be set first, before M2-29 (M2-ETH 1 min) and M2-30 (M2-ETH Cont) settings can be used.</li> </ul> |

### Parameter Setting at Multi-function Terminal Input on a Second Motor

| Code                 | Description          | Code                | Description                        |
|----------------------|----------------------|---------------------|------------------------------------|
| M2-04 Acc Time       | Acceleration time    | M2-15 M2-Efficiency | Motor efficiency                   |
| M2-05 M2-Dec Time    | Deceleration time    | M2-17 M2-Rs         | Stator resistance                  |
| M2-06 M2-Capacity    | Motor capacity       | M2-18 M2-Lsigma     | Leakage inductance                 |
| M2-07 M2-Base Freq   | Motor base frequency | M2-25 M2-V/F Patt   | V/F pattern                        |
| M2-08 M2-Ctrl Mode   | Control mode         | M2-26 M2-Fwd Boost  | Forward torque boost               |
| M2-10 M2-Pole Num    | Pole number          | M2-27 M2-Rev Boost  | Reverse torque boost               |
| M2-11 M2-Rate Slip   | Rated slip           | M2-28 M2-Stall Lev  | Stall prevention level             |
| M2-12 M2-Rated Curr  | Rated current        | M2-29 M2-ETH 1 min  | Motor heat protection 1 min rating |
| M2-13 M2-Noload Curr | No-load current      | M2-30 M2-ETH Cont   | Motor heat protection              |

| Code                | Description         | Code | Description       |
|---------------------|---------------------|------|-------------------|
|                     |                     |      | continuous rating |
| M2-14 M2-Rated Volt | Motor-rated voltage |      |                   |

**Example - 2nd Motor Operation**

Use the 2nd motor operation when switching operations between a 7.5 kW motor and a secondary 3.7 kW motor using terminal P3. Refer to the following settings.

| Group | Code | Name                      | LCD Display  | Parameter Setting |           | Setting Range | Unit |
|-------|------|---------------------------|--------------|-------------------|-----------|---------------|------|
| IN    | 67   | Terminal P3 configuration | P3 Define    | 26                | 2nd Motor | -             | -    |
| M2    | 06   | Motor capacity            | M2-Capacity  | -                 | 3.7 kW    | -             | -    |
|       | 08   | Control mode              | M2-Ctrl Mode | 0                 | V/F       | -             | -    |

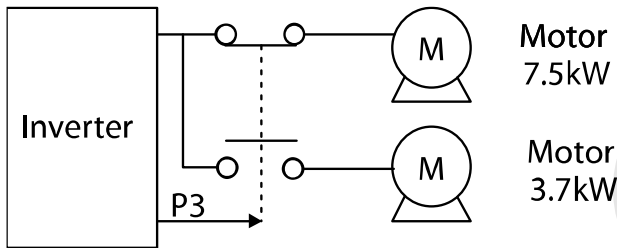

### 8.23 Supply Power Transition

A supply power transition is used to switch the power source for the motor connected to the inverter from the inverter output power to the main supply power source (commercial power source), or vice versa.

| Group | Code  | Name                      | LCD Display                                       | Parameter Setting |               | Setting Range | Unit |
|-------|-------|---------------------------|---|-------------------|---------------|---------------|------|
| IN    | 65–75 | Px terminal configuration | Px Define<br>(Px: P1–P8<br>[optional:<br>P9–P11]) | 16                | Exchange      | -             | -    |
| OUT   | 31–32 | Multi-function relay 1–2  | Relay1–2  | 17                | Inverter Line | -             | -    |
|       | 33    | Multi-function output 1   | Q1 Define   | 18                | Comm Line     | -             | -    |

**Supply Power Transition Setting Details**

| Code   | Description   |
|--|---|
| IN-65-75<br>Px Define                                  | When the motor power source changes from the inverter output to the main power supply, select a terminal to use and set the code value to "16 (Exchange)". Power will be switched when the selected terminal is on. To reverse the transition, switch off the terminal. |
| OUT-31 Relay 1,<br>OUT-32 Relay 2,<br>OUT-33 Q1 Define | <p>Set the multi-function relay or multi-function output to "17 (Inverter Line)" or "18 (Comm Line)". The relay operation sequence is as follows.</p>   |

## 8.24 Cooling Fan Control

This function turns the inverter’s heatsink cooling fan on and off. It is used in situations where the load stops and starts frequently or when a noise-free environment is required. The correct use of cooling fan controls can extend the cooling fan’s life.

| Group | Code | Name                | LCD Display | Parameter Setting | Setting Range | Unit |   |
|-------|------|---------------------|-------------|-------------------|---------------|------|---|
| ADV   | 64   | Cooling fan control | Fan Control | 0                 | During Run    | 0-2  | - |
|       |      |                     |             | 1                 | Always On     |      |   |
|       |      |                     |             | 2                 | Temp Control  |      |   |

**Cooling Fan Control Detail Settings**

| Code               | Description  |   |  |
|--------------------|--------------|---|--|
| ADV-64 Fan Control | Settings     |   |  |
|                    | Description  |   |  |
|                    | 0            | During Run  | The cooling fan runs when the power is supplied to the inverter and the operation command is on. The cooling fan stops when the power is supplied to the inverter and the operation command is off. When the inverter heat sink temperature is higher than its set value, the cooling fan operates automatically regardless of its operation status. |
|                    | 1            | Always On   | The cooling fan runs constantly if power is supplied to the inverter.  |
| 2                  | Temp Control | With power connected and the run operation command on: if the setting is in Temp Control, the cooling fan will not operate unless the temperature in the heat sink reaches the set temperature. |  |

**Note**

In 11–75 kW model types, if the heat sink temperature reaches a set level by input current harmonic waves or noise, the cooling fan may run to protect the inverter even when ADV-64 is set to “0 (During Run)”.

**8.25 Input Power Frequency Settings**

Select the frequency for inverter input power. If the frequency changes from 60 Hz to 50 Hz, all other frequency (or RPM) settings, including the maximum frequency, base frequency, etc., will change to 50 Hz. Likewise, changing the input power frequency setting from 50 Hz to 60 Hz will change all related function item settings from 50 Hz to 60 Hz.

| Group | Code | Name                  | LCD Display  | Parameter Setting | Setting Range | Unit |
|-------|------|-----------------------|--------------|-------------------|---------------|------|
| BAS   | 10   | Input power frequency | 60/50 Hz Sel | 0 60 Hz           | 0–1           | -    |



## 8.26 Input Power Voltage Settings

Set the inverter input power voltage. The low voltage fault trip level changes automatically according to the set voltage standard.

| Group | Code | Name                | LCD Display   | Parameter Setting |     | Setting Range | Unit |
|-------|------|---------------------|---------------|-------------------|-----|---------------|------|
| BAS   | 19   | Input power voltage | AC Input Volt | 200 Type          | 220 | 170–230       | V    |
|       |      |                     |               | 400 Type          | 380 | 380–480       |      |

## 8.27 Read, Write, and Save Parameters

Use read, write, and save parameter functions to copy parameters from the inverter to the keypad or from the keypad to the inverter.

| Group | Code | Name            | LCD Display     | Parameter Setting |     | Setting Range | Unit |
|-------|------|-----------------|-----------------|-------------------|-----|---------------|------|
| CNF   | 46   | Parameter read  | Parameter Read  | 1                 | Yes | -             | -    |
|       | 47   | Parameter write | Parameter Write | 1                 | Yes | -             | -    |
|       | 48   | Parameter save  | Parameter Save  | 1                 | Yes | -             | -    |

### Read, Write, and Save Parameter Setting Details

| Code                   | Description   |
|------------------------|---|
| CNF-46 Parameter Read  | Copies saved parameters from the inverter to the keypad. Saved parameters on the keypad will be deleted and replaced with the copied parameters.  |
| CNF-47 Parameter Write | Copies saved parameters from the keypad to the inverter. Saved parameters on the inverter will be deleted and replaced with the copied parameters. If an error occurs during parameter writing, the previously saved data will be used. If there is no saved data on the keypad, “EEP Rom Empty” will be displayed. |
| CNF-48 Parameter Save  | As parameters set during communication transmission are saved in RAM, the setting values will be lost if the power turns off and on. When setting parameters during communication transmission, select “1 (Yes)” at CNF-48 to save the set parameters.  |

**Caution** 

When utilizing the optional communication module, note the following information if you need to read or write the parameter values set at COM-10-25 (Opt Parameter).

1. Because the "Opt Parameter" (COM-10-25) values are stored in the optional add-on module, you must run "Comm Update" (COM-94) to apply the changes after making changes to the parameter settings.
2. You must save the parameter values set at COM-10-25 (Opt Parameter) by running "Parameter Save" before you can read or write the "Opt Parameter" parameters.

## 8.28 Parameter Initialization

User changes to parameters can be initialized (reset) to factory default settings on all or selected groups. Parameters cannot be reset during operation or a fault trip condition.

| Group | Code | Name                     | LCD Display    | Parameter Setting |    | Setting Range | Unit |
|-------|------|--------------------------|----------------|-------------------|----|---------------|------|
| CNF   | 40   | Parameter initialization | Parameter Init | 0                 | No | 0–15          |      |

### Parameter Initialization Setting Details

| Code                  | Description         |                       |             |   |
|-----------------------|---------------------|-----------------------|-------------|---|
| CNF-40 Parameter Init | Setting             |                       | LCD Display | Function  |
|                       | 0                   | No                    | No          | -   |
|                       | 1                   | Initialize all groups | All Grp     | Initialize all data. Select "1 (All Grp)" and press the [PROG/ENT] key to start initialization. On completion, "0 (No)" will be displayed.          |
|                       | 2                   | Initialize DRV group  | DRV Grp     | Initialize data by groups. Select Initialize group and press the [PROG/ENT] key to start initialization. On completion, "0 (No)" will be displayed. |
|                       | 3                   | Initialize BAS group  | BAS Grp     |   |
|                       | 4                   | Initialize ADV group  | ADV Grp     |   |
|                       | 5                   | Initialize CON group  | CON Grp     |   |
|                       | 6                   | Initialize IN group   | IN Grp      |   |
|                       | 7                   | Initialize OUT group  | OUT Grp     |   |
|                       | 8                   | Initialize COM group  | COM Grp     |   |
|                       | 9                   | Initialize APP group  | APP Grp     |   |
|                       | 10                  | Initialize AUT group  | AUT Grp     |   |
|                       | 11                  | Initialize APO group  | APO Grp     |   |
|                       | 12                  | Initialize PRT group  | PRT Grp     |   |
| 13                    | Initialize M2 group | M2 Grp                |             |   |

## 8.29 Parameter Viewing and Lock Options

### 8.29.1 Parameter View Lock

Use parameter view lock to hide parameter mode (PAR mode) after registering and entering a user password. Other modes (CNF, U&M, MAC and TRP modes) will still be visible when the parameter view lock is enabled.

| Group | Code | Name                         | LCD Display   | Parameter Setting | Setting Range | Unit |
|-------|------|------------------------------|---------------|-------------------|---------------|------|
| CNF   | 50   | Parameter view lock          | View Lock Set | Unlocked          | 0-9999        | -    |
|       | 51   | Parameter view lock password | View Lock Pw  | Password          | 0-9999        | -    |

#### Parameter View Lock Setting Details

| Code                 | Description   |   |           |   |   |   |   |   |   |   |                          |   |   |
|----------------------|---|---|-----------|---|---|---|---|---|---|---|--------------------------|---|---|
| CNF-51 View Lock Pw  | Register a password to allow access to parameter view lock. Follow the steps below to register a password.  |   |           |   |   |   |   |   |   |   |                          |   |   |
|                      | <table border="1"> <thead> <tr> <th>No</th> <th>Procedure</th> </tr> </thead> <tbody> <tr> <td>1</td> <td>Press the [PROG/ENT] key on code CNF-51 to show the previous password input window. If a password is being registered for the first time, enter "0". It is the factory default.</td> </tr> <tr> <td>2</td> <td>If a password had been set, enter the saved password.</td> </tr> <tr> <td>3</td> <td>If the entered password matches the saved password, a new window prompting the user to enter a new password will be displayed (the process will not progress to the next stage until the user enters a valid password).</td> </tr> <tr> <td>4</td> <td>Register a new password.</td> </tr> <tr> <td>5</td> <td>After registration, code CNF-51 (View Lock PW) will be displayed.</td> </tr> </tbody> </table> | No  | Procedure | 1 | Press the [PROG/ENT] key on code CNF-51 to show the previous password input window. If a password is being registered for the first time, enter "0". It is the factory default. | 2 | If a password had been set, enter the saved password. | 3 | If the entered password matches the saved password, a new window prompting the user to enter a new password will be displayed (the process will not progress to the next stage until the user enters a valid password). | 4 | Register a new password. | 5 | After registration, code CNF-51 (View Lock PW) will be displayed. |
|                      | No  | Procedure   |           |   |   |   |   |   |   |   |                          |   |   |
|                      | 1   | Press the [PROG/ENT] key on code CNF-51 to show the previous password input window. If a password is being registered for the first time, enter "0". It is the factory default.   |           |   |   |   |   |   |   |   |                          |   |   |
|                      | 2   | If a password had been set, enter the saved password.   |           |   |   |   |   |   |   |   |                          |   |   |
|                      | 3   | If the entered password matches the saved password, a new window prompting the user to enter a new password will be displayed (the process will not progress to the next stage until the user enters a valid password). |           |   |   |   |   |   |   |   |                          |   |   |
| 4                    | Register a new password.  |   |           |   |   |   |   |   |   |   |                          |   |   |
| 5                    | After registration, code CNF-51 (View Lock PW) will be displayed.   |   |           |   |   |   |   |   |   |   |                          |   |   |
| CNF-50 View Lock Set | To enable parameter view lock, enter a registered password. The [Locked] sign will be displayed on the screen to indicate that parameter view lock is enabled. To disable parameter view lock, re-enter the password. The [locked] sign will disappear, and PAR mode becomes visible again.   |   |           |   |   |   |   |   |   |   |                          |   |   |
|                      |   |   |           |   |   |   |   |   |   |   |                          |   |   |

### 8.29.2 Parameter Lock

Use parameter lock to prevent unauthorized modification of parameter settings. To enable parameter lock, register and enter a user password first.

| Group | Code | Name                    | LCD Display  | Parameter Setting | Setting Range | Unit |
|-------|------|-------------------------|--------------|-------------------|---------------|------|
| CNF   | 52   | Parameter lock          | Key Lock Set | Unlocked          | 0-9999        | -    |
|       | 53   | Parameter lock password | Key Lock Pw  | Password          | 0-9999        | -    |

#### Parameter Lock Setting Details

| Code   | Description  |
|--|--|
| CNF-53 Key Lock PW                                     | Register a password to prohibit parameter modifications. Follow the procedures below to register a password.   |
|  | No   Procedures  |
|  | 1   Press the [PROG/ENT] key on code CNF-53 to display the saved password input window. If a password is being registered for the first time, enter "0". It is the factory default.  |
|  | 2   If a saved password has been set, enter the saved password.  |
|  | 3   If the entered password matches the saved password, then a new window to enter a new password will be displayed. (The process will not progress to the next stage until the user enters a valid password).   |
|  | 4   Register a new password.   |
| 5   After registration, code CNF-53 will be displayed. |  |
| CNF-52 Key Lock Set                                    | To enable parameter lock, enter the registered password. The [Locked] sign will be displayed on the screen to indicate that prohibition is enabled. Once enabled, pressing the [PROG/ENT] key will not allow the edit mode to run. To disable parameter lock, re-enter the password. The [Locked] sign will disappear. |

#### ⚠ Caution

If parameter view lock and parameter lock functions are enabled, no inverter operation related function changes can be made. It is very important that you memorize the password.

### 8.29.3 Changed Parameter Display

This feature displays all the parameters that are different from the factory defaults. Use this feature to track changed parameters.

| Group | Code | Name                      | LCD Display  | Parameter Setting |              | Setting Range | Unit |
|-------|------|---------------------------|--------------|-------------------|--------------|---------------|------|
| CNF   | 41   | Changed parameter display | Changed Para | 1                 | View Changed | -             | -    |

#### Changed Parameter Display Setting Details



| Code                   | Description |              |                                 |
|------------------------|-------------|--------------|---------------------------------|
| CNF-41<br>Changed Para | Setting     |              | Function                        |
|                        | 0           | View All     | Display all parameters          |
|                        | 1           | View Changed | Display changed parameters only |

## 8.30 User Group

Create a user-defined group and register user-selected parameters from the existing function groups. The user group can carry up to a maximum of 64 parameter registrations.

| Group | Code | Name                             | LCD Display    | Parameter Setting |                | Setting Range | Unit |
|-------|------|----------------------------------|----------------|-------------------|----------------|---------------|------|
| CNF   | 42   | Multi-function key settings      | Multi Key Sel  | 3                 | UserGrp SelKey | -             | -    |
|       | 45   | Delete all user registered codes | UserGrp AllDel | 0                 | No             | -             | -    |

#### User Group Setting Details

| Code                 | Description   |    |           |   |  |   |
|----------------------|---|----|-----------|---|--|---|
| CNF-42 Multi Key Sel | Selects "3 (UserGrp SelKey)" from the multi-function key setting options. If user group parameters are not registered, setting the multi-function key to the user group select key (UserGrp SelKey) will not display user group (USR Grp) items on the keypad.  |    |           |   |  |   |
|                      | Follow the procedures below to register parameters to a user group.   |    |           |   |  |   |
|                      | <table border="1"> <thead> <tr> <th>No</th> <th>Procedure</th> </tr> </thead> <tbody> <tr> <td>1</td> <td>Set CNF- 42 to "3 (UserGrp SelKey)". The  icon will be displayed at the top of the LCD display.</td> </tr> <tr> <td>2</td> <td>In the parameter mode (PAR Mode), move to the parameter you need</td> </tr> </tbody> </table> | No | Procedure | 1 | Set CNF- 42 to "3 (UserGrp SelKey)". The  icon will be displayed at the top of the LCD display. | 2 |
| No                   | Procedure   |    |           |   |  |   |
| 1                    | Set CNF- 42 to "3 (UserGrp SelKey)". The  icon will be displayed at the top of the LCD display.  |    |           |   |  |   |
| 2                    | In the parameter mode (PAR Mode), move to the parameter you need  |    |           |   |  |   |

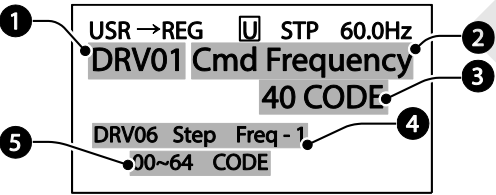
| Code   | Description  |
|--|--|
|  | <p>to register and press the [MULTI] key. For example, if the [MULTI] key is pressed in the frequency reference in DRV-01 (Cmd Frequency), the screen below will be displayed.</p>  <ol style="list-style-type: none"> <li>① Group name and code number of the parameter.</li> <li>② Name of the parameter.</li> <li>③ Code number to be used in the user group. Pressing the [PROG/ENT] key on the code number (40 Code) will register DRV-01 as code 40 in the user group.</li> <li>④ Existing parameter registered as the user group code 40.</li> <li>⑤ Setting range of the user group code. Entering “0” cancels the settings.</li> </ol> |
| 3  | <p>③ Set a code number to use to register the parameter in the user group. Select the code number and press the [PROG/ENT] key.</p>  |
| 4  | <p>Changing the value in ③ will also change the value in ④. If no code is registered, “Empty Code” will be displayed. Entering “0” cancels the settings.</p>   |
| 5  | <p>The registered parameters are listed in the user group in U&amp;M mode. You can register one parameter multiple times if necessary. For example, a parameter can be registered as code 2, code 11, etc. in the user group.</p>  |
| <p>Follow the procedures below to delete parameters in the user group.</p> |  |
| No.  | Settings   |
| 1  | Set CNF- 42 to “3 (UserGrp SelKey)”. The <input type="checkbox"/> icon will be displayed at the top of the LCD display.  |
| 2  | In the USR group in U&M mode, move the cursor to the code that is to be deleted.   |
| 3  | Press the [MULTI] key.   |
| 4  | Select “YES” on the deletion confirmation screen, and press the [PROG/ENT] key.  |
| 5  | The parameter is deleted.  |
| CNF-25 UserGrp AllDel  | Set to “1 (Yes)” to delete all registered parameters in the user group.  |

### 8.31 Macro Selection

The macro selection function is used to put various application functions together in a group. For applications with the iS7 series inverters, two basic macro configurations for “Draw”\* and “Traverse” applications (MC1 and MC2) are currently available in U&M mode. Macro functions cannot be added by the user, but the data can be modified.

| Group | Code | Name            | LCD Display  | Parameter Setting |          | Setting Range | Unit |
|-------|------|-----------------|--------------|-------------------|----------|---------------|------|
| CNF   | 43   | Macro selection | Macro Select | 0                 | None     | 0–2           | -    |
|       |      |                 |              | 1                 | Draw     |               |      |
|       |      |                 |              | 2                 | Traverse |               |      |

\*The draw application is an open loop tension control which maintains a stable tension load applied to the material by utilizing the difference between the main reference and the auxiliary reference (Refer to [8.1 Operating with Auxiliary References](#) on page [194](#) for details).

#### Macro Selection Details

| Code                | Description   |
|---------------------|---|
| CNF-43 Macro Select | A list of macro settings is displayed for user selection. When a macro function is selected, all the related parameters are automatically changed based on the inverter’s macro settings. |

## 8.32 Easy Start

Run Easy Start to easily set up the basic motor parameters required to operate a motor in a batch. Set CNF-61 (Easy Start On) to “1 (Yes)” to activate the feature, initialize all parameters by setting CNF-40 (Parameter Init) to “1 (All Grp)”, and restart the inverter to activate Easy Start.

| Group | Code | Name                          | LCD Display   | Parameter Setting |     | Setting Range | Unit |
|-------|------|-------------------------------|---------------|-------------------|-----|---------------|------|
| CNF   | 61   | Parameter easy start settings | Easy Start On | 1                 | Yes | -             | -    |

### Easy Start Setting Details

| Code                 | Description  |  |            |   |  |   |  |
|----------------------|--|--|------------|---|--|---|--|
| CNF-61 Easy Start On | Follow the procedures listed below to set the Easy Start parameters.   |  |            |   |  |   |  |
|                      | <table border="1"> <thead> <tr> <th>No</th> <th>Procedures</th> </tr> </thead> <tbody> <tr> <td>1</td> <td>Set CNF-61 (Easy Start On) to “1 (Yes)”.</td> </tr> <tr> <td>2</td> <td>Set CNF-40 (Parameter Init) to “1 (All Grp)” to initialize all parameters in the inverter.</td> </tr> </tbody> </table>   | No                                       | Procedures | 1 | Set CNF-61 (Easy Start On) to “1 (Yes)”. | 2 | Set CNF-40 (Parameter Init) to “1 (All Grp)” to initialize all parameters in the inverter. |
|                      | No   | Procedures                               |            |   |  |   |  |
|                      | 1  | Set CNF-61 (Easy Start On) to “1 (Yes)”. |            |   |  |   |  |
| 2                    | Set CNF-40 (Parameter Init) to “1 (All Grp)” to initialize all parameters in the inverter.   |  |            |   |  |   |  |
| 3                    | <p>Restarting the inverter will activate Easy Start. Set the values in the following screens on the keypad. To exit Easy Start, press the [ESC] key.</p> <p>Start Easy Set: Select “Yes”.</p> <p>CNF-01 Language Sel: Select a language.</p> <p>DRV-30 kW/HP Select : select the capacity of the unit.</p> <p>DRV-14 Motor Capacity: Set motor capacity.</p> <p>BAS-11 Pole Number: Set motor pole number.</p> <p>BAS-15 Rated Volt: Set motor rated voltage.</p> <p>BAS-10 60/50 Hz Sel: Set motor rated frequency.</p> <p>BAS-19 AC Input Volt: Set input voltage.</p> <p>DRV-06 Cmd Source: Set command source.</p> <p>DRV-01 Cmd Frequency: Set frequency reference.</p> <p>When the settings are complete, the minimum parameter settings on the motor have been made. The keypad will return to a monitoring display. Now the motor can be operated with the command source set at DRV-06.</p> |  |            |   |  |   |  |



### 8.33 Config (CNF) Mode

The config mode parameters are used to configure keypad-related features.

| Group | Code  | Name  | LCD Display       | Parameter Setting |          | Setting Range | Unit |
|-------|-------|---|-------------------|-------------------|----------|---------------|------|
| CNF*  | 2     | LCD brightness/<br>contrast adjustment                      | LCD Contrast      | -                 |          | -             |      |
|       | 10    | Inverter S/W version  | Inv S/W Ver       | x.xx              |          | -             |      |
|       | 11    | Keypad S/W version  | Keypad S/W Ver    | x.xx              |          | -             | -    |
|       | 12    | Keypad title version  | KPD Title Ver     | x.xx              |          | -             | -    |
|       | 30–32 | Power slot type   | Option-x Type     | None              |          | -             | -    |
|       | 41    | Display changed<br>parameters                               | Changed Para      | 0                 | View All | 0–1           | -    |
|       | 44    | Erase trip history  | Erase All Trip    | No                |          | -             | -    |
|       | 60    | Add title update  | Add Title Up      | No                |          | -             | -    |
|       | 62    | Initialize accumulated<br>electrical energy                 | WH Count<br>Reset | No                |          | -             | -    |
|       | 74    | Accumulated cooling<br>fan operation time                   | Fan Time          | 0000DAY 00:00     |          |               |      |
|       | 75    | Accumulated cooling<br>fan operation time<br>initialization | Fan Time Rst      | 0                 | No       |               |      |

#### Config Mode Parameter Setting Details

| Code   | Description  |
|--|--|
| CNF-2 LCD Contrast                           | Adjusts LCD brightness/contrast on the keypad.   |
| CNF-10 Inv S/W Ver,<br>CNF-11 Keypad S/W Ver | Checks the OS version in the inverter and on the keypad.   |
| CNF-12 KPD Title Ver                         | Checks the title version on the keypad.  |
| CNF-30–32 Option-x Type                      | Checks the type of option board installed in the option slot.  |
| CNF-41 Changed Para                          | Displays all the parameters that are different from the factory defaults.  |
| CNF-44 Erase All Trip                        | Deletes the stored trip history.   |
| CNF-60 Add Title UP                          | When the inverter SW version is updated and more code is added, CNF-60 settings will add, display, and operate the added codes. Set CNF-60 to “1 (Yes)” and disconnect the keypad from the inverter. Reconnecting the keypad to the inverter updates titles. |
| CNF-62 WH Count Reset                        | Initialize the accumulated electrical energy consumption count.  |

| Code                | Description  |
|---------------------|--|
| CNF-74 Fan Time     | Displays the accumulated cooling fan operation time.             |
| CNF-75 Fan Time Rst | Initialize the accumulated cooling fan operation time at CNF-74. |

### 8.34 Timer Settings

Set a multi-function input terminal to a timer and set the On/Off controls to the multi-function outputs and relays according to the timer settings.

| Group | Code  | Name                      | LCD Display                              | Parameter Setting |             | Setting Range | Unit |
|-------|-------|---------------------------|--|-------------------|-------------|---------------|------|
| IN    | 65–75 | Px terminal configuration | Px Define (Px: P1–P8 [optional: P9–P11]) | 38                | Timer In    | -             | -    |
| OUT   | 31    | Multi-function relay 1    | Relay 1                                  | 28                | Timer Out   | -             | sec  |
|       | 33    | Multi-function output 1   | Q1 Define                                |                   |             |               |      |
|       | 55    | Timer on delay            | TimerOn Delay                            | 0.00              | 0.00–100.00 | sec           |      |
|       | 56    | Timer off delay           | TimerOff Delay                           | 0.00              | 0.00–100.00 | sec           |      |

#### Timer Setting Details

| Code  | Description   |
|---|---|
| IN-65–75 Px Define                          | Selects one of the multi-function input terminals and change it to a timer terminal by setting it to “38 (Timer In)”.   |
| OUT-31 Relay 1, OUT-36 Q1 Define            | Sets the multi-function output terminal or relay to be used as a timer to “28 (Timer out)”.   |
| OUT-55 TimerOn Delay, OUT-56 TimerOff Delay | Inputs a signal (On) to the timer terminal to operate a timer output (Timer out) after the time set at OUT-55 has passed. When the multi-function input terminal is off, the multi-function output or relay turns off after the time set at OUT-56. |

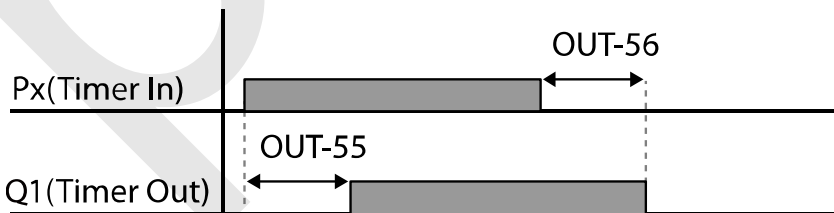

## 8.35 Traverse Operation

The traverse operation is used to periodically change the motor rotation. In its application as a winder, the traverse operation ensures that the thread or wire is evenly wound on a spindle without tangles.

| Group | Code  | Name                        | LCD Display                              | Parameter Setting |               | Setting Range | Unit |
|-------|-------|-----------------------------|--|-------------------|---------------|---------------|------|
| APP   | 01    | Applied function selection  | App Mode                                 | 1                 | Traverse      | 0–4           | -    |
|       | 08    | Traverse operating range    | Trv Amplit %                             | -                 | 0.0           | 0–20          | %    |
|       | 09    | Traverse scramble magnitude | Trv Scramb %                             | -                 | 0.0           | 0–50          | %    |
|       | 10    | Traverse acceleration time  | Trv Acc Time                             | -                 | 2.0           | 0.1–600.0     | Sec  |
|       | 11    | Traverse deceleration time  | Trv Dec Time                             | -                 | 3.0           | 0.1–600.0     | Sec  |
|       | 12    | Traverse offset upper limit | Trv Offset Hi                            | -                 | 0.0           | 0–20.0        | %    |
|       | 13    | Traverse offset lower limit | Trv Offset Lo                            | -                 | 0.0           | 0–20.0        | %    |
| IN    | 65–75 | Px terminal configuration   | Px Define (Px: P1–P8 [optional: P9–P11]) | 27                | Trv Offset Lo | -             | -    |
|       |       |                             |  | 28                | Trv Offset Hi | -             | -    |

### Traverse Operation Details

| Code                | Description  |         |               |   |      |   |          |   |          |   |          |   |               |
|---------------------|--|---------|---------------|---|------|---|----------|---|----------|---|----------|---|---------------|
| APP-01 APP Mode     | <p>Set APP-01 to “1 (Traverse)”. Parameters for the traverse operation become visible.</p> <table border="1"> <thead> <tr> <th>Setting</th> <th>Function mode</th> </tr> </thead> <tbody> <tr> <td>0</td> <td>None</td> </tr> <tr> <td>1</td> <td>Traverse</td> </tr> <tr> <td>2</td> <td>Proc PID</td> </tr> <tr> <td>3</td> <td>Reserved</td> </tr> <tr> <td>4</td> <td>Auto Sequence</td> </tr> </tbody> </table> | Setting | Function mode | 0 | None | 1 | Traverse | 2 | Proc PID | 3 | Reserved | 4 | Auto Sequence |
| Setting             | Function mode  |         |               |   |      |   |          |   |          |   |          |   |               |
| 0                   | None   |         |               |   |      |   |          |   |          |   |          |   |               |
| 1                   | Traverse   |         |               |   |      |   |          |   |          |   |          |   |               |
| 2                   | Proc PID   |         |               |   |      |   |          |   |          |   |          |   |               |
| 3                   | Reserved   |         |               |   |      |   |          |   |          |   |          |   |               |
| 4                   | Auto Sequence  |         |               |   |      |   |          |   |          |   |          |   |               |
| APP-08 Trv Amplit % | Sets the operation frequency for the scramble operation as a percentage of the inverter’s frequency reference.   |         |               |   |      |   |          |   |          |   |          |   |               |
| APP-09 Trv Scramb % | Sets the scramble frequency (frequency jump volume at the beginning of a deceleration) for traverse operation as a percentage of the traverse operation frequency.   |         |               |   |      |   |          |   |          |   |          |   |               |

| Code  | Description  |
|---|--|
| APP-10 Trv Acc Time,<br>APP-11 Trv Dec Time | Sets the acceleration and deceleration time for the traverse operation.  |
| APP-12 Trv Offset Hi                        | Sets the high offset amount for the traverse operation as a percentage of the inverter's frequency reference.<br>After setting one of the multi-function terminals to "28 (Trv Offset Hi)", the offset value is added to the traverse operation frequency when the terminal input is on. |
| APP-13 Trv Offset Lo                        | Sets the low offset amount for traverse operation as a percentage of the inverter's frequency reference.<br>After setting one of the multi-function terminals to "27 (Trv Offset Lo)", the offset value is deducted from the traverse operation frequency when the terminal input is on. |

## 8.36 Brake Control

Brake control is used to control the On/Off operation of the electronic brake load system. Check the inverter's control mode set at DRV-09 before configuring the brake control sequence as the operation sequence varies by the control mode.

| Group | Code  | Name                            | LCD Display   | Parameter Setting |              | Setting Range | Unit |
|-------|-------|---------------------------------|---------------|-------------------|--------------|---------------|------|
| DRV   | 09    | Control mode                    | Control Mode  | 0                 | V/F          | -             | -    |
|       |       |                                 |               | 1                 | V/F PG       |               |      |
|       |       |                                 |               | 2                 | Slip Compen  |               |      |
|       |       |                                 |               | 3                 | Sensorless-1 |               |      |
|       |       |                                 |               | 4                 | Sensorless-2 |               |      |
|       |       |                                 |               | 5                 | Vector       |               |      |
| ADV   | 41    | Brake release current           | BR Rls Curr   | 50.0              |              | 0.0–180.0%    | %    |
|       | 42    | Brake release delay time        | BR Rls Dly    | 1.00              |              | 0–10.00       | sec  |
|       | 44    | Brake release forward frequency | BR Rls Fwd Fr | 1.00              |              | 0–400         | Hz   |
|       | 45    | Brake release reverse frequency | BR Rls Rev Fr | 1.00              |              | 0–400         | Hz   |
|       | 46    | Brake engage delay time         | BR Eng Dly    | 1.00              |              | 0–10          | sec  |
|       | 47    | Brake engage frequency          | BR Eng Fr     | 2.00              |              | 0–400         | Hz   |
| OUT   | 31–32 | Multi-function relay1–2         | Relay 1–2     | 35                | BR Control:  | -             | -    |
|       | 33    | Multi-function output1 item     | Q1 Define     |                   |              |               |      |

**Brake Control Details**

| Code   | Description  |
|--|--|
| <p>ADV-12 Dc-Start Time</p> <p>ADV-15 Dc Brake Time<br/>ADV-16 Dc Brake Level</p> <p>ADV-20 Acc Dwell Freq,<br/>ADV-21 Acc Dwell Time,<br/>ADV-22 Dec Dwell Freq,<br/>ADV-23 Dec Dwell Time</p> <p>ADV-42 BR Rls Dly<br/>ADV-44 BR Rls Fwd Fr<br/>ADV-45 BR Rls Rev Fr<br/>ADV-46 BR Eng Dly<br/>ADV-47 BR Eng Dly</p> | <p>When the brake control is activated, DC braking (ADV-12) at inverter start and dwell operation (ADV-20–23) do not operate.</p> <p><b>Brake Operation Sequence in Control Modes Other than “Vector”</b></p> <p><b>&lt;Brake release sequence&gt;</b><br/>During the motor stop state, if an operation command is entered, the inverter accelerates up to the brake release frequency (ADV-44–45) in a forward or reverse direction.<br/>After reaching the brake release frequency, if the motor current reaches the brake release current (BR Rls Curr), the output relay or multi-function output terminal for brake control sends a release signal.<br/>Once the signal has been sent, acceleration will begin after maintaining the frequency for the brake release delay time (ADV-42 BR Rls Dly).</p> <p><b>&lt;Brake engage sequence&gt;</b><br/>If a stop command is sent during operation, the motor decelerates. Once the output frequency reaches the brake engage frequency (ADV-47 BR Eng Fr), the motor stops decelerating and sends out a brake engage signal to a preset output terminal.<br/>The frequency is maintained for the brake engage delay time (ADV-47 BR Eng Dly) and it becomes “0” afterwards. If the DC braking time (ADV-15) and DC braking resistance (ADV-16) are set, the inverter output is blocked after DC braking. For more details on DC braking, refer to <u>7.17.2 Stop after DC Braking</u> on page 184.</p> <p><b>Brake Operation Sequence in “Vector” control Mode</b></p> <p><b>&lt;Brake release sequence&gt;</b><br/>When an operational command is entered, the output relay or multi-function output terminal for brake control sends a brake release signal after the pre-excitation time is passed. Once the signal has been sent, acceleration will begin after the brake release delay time (ADV-42 BR Rls Dly) has passed.</p> <p><b>&lt;Brake engage sequence&gt;</b><br/>If a stop command is sent during operation, the inverter decelerates to “0 Hz” and sends out a brake engage signal. Then, the output is cut off after the brake engage delay time (ADV-46 BR Eng Dly) has passed. The brake engage sequence does not operate in torque control mode.</p> |

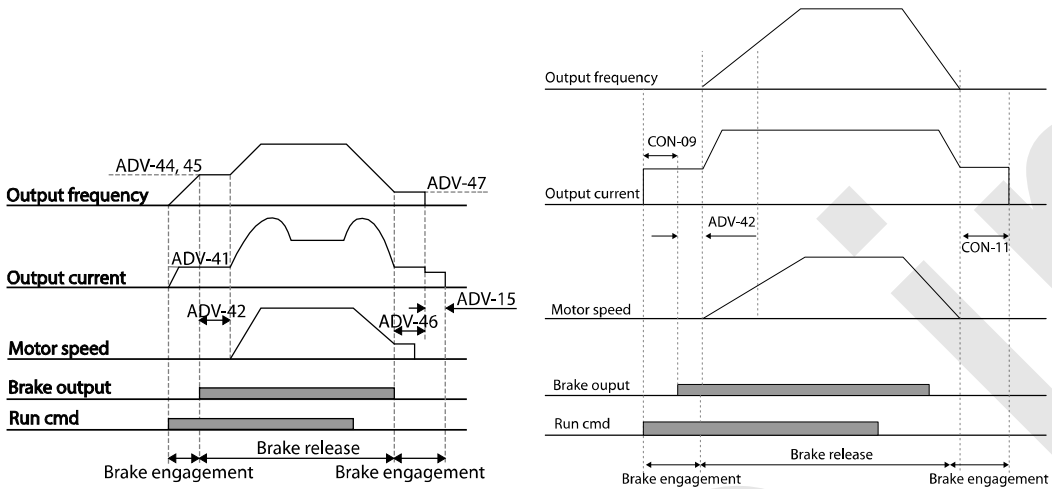

### 8.37 Multi-function Output On/Off Control

| Group | Code  | Name  | LCD Display     | Parameter Setting | Setting Range             | Unit |
|-------|-------|---|-----------------|-------------------|---------------------------|------|
| ADV   | 66    | Output contact On/Off control options         | On/Off Ctrl Src | 1 V1              | 0-4                       | -    |
|       | 67    | Output contact point On level                 | On-C Level      | - 90.00           | 10-100                    | %    |
|       | 68    | Output contact point Off level                | Off-C Level     | - 10.00           | 0-Output contact on level | %    |
| OUT   | 31-33 | Multi-function relay, Multi-function output 1 | Relay x or Q1   | 34 On/Off Control | -                         | -    |

#### Multi-function Output On/Off Control Details

| Code  | Description   |
|---|---|
| ADV-66 On/Off Ctrl Src<br>ADV-67 On-C Level<br>ADV-68 Off-C Level | <p>If the analog input value exceeds the set value, the output relay or multi-function output terminal can be turned on or off. Select the analog input to use for On/Off control at ADV-66 and set the levels at which the output terminal is on and off at ADV-67 and 68 respectively.</p> <p>If the analog input value exceeds the value set at ADV-67, the output terminal is on. If the analog input is below the value set at ADV-68, the output terminal is off.</p> |

## 8.38 MMC function

The MMC (Multiple Motor Control) function is used to control multiple motors of a pump system. The main motor connected with the inverter output is controlled by the PID controller. The auxiliary motors are connected with the supply power and turned on and off by the relay within the inverter.

The relay for controlling auxiliary motors uses Relay 1 and 2 in the standard I/O module embedded in the inverter and multi-function output terminal Q1. If the I/O expansion option module is connected to the inverter option slot, up to 3 relay outputs can be used.

| Group | Code                      | Name                             | LCD Display   | Parameter Setting |          | Setting Range | Unit |
|-------|---------------------------|----------------------------------|---------------|-------------------|----------|---------------|------|
| APP   | 01                        | Application mode                 | App Mode      | 3                 | MMC      | -             | -    |
| APO   | 20                        | Aux motor rotation number        | Aux Motor Run | -                 | 0        | 0-4           | -    |
|       | 21                        | Starting aux motor selection     | Starting Aux  | -                 | 1        | 1-4           | -    |
|       | 22                        | Auto operation time              | Auto Op Time  | -                 | 0:00     | xx:xx         | Min  |
|       | 23                        | 1st aux motor starting frequency | Start Freq 1  | -                 | 49.99    | 0-60          | Hz   |
|       | 24                        | 2nd aux motor starting frequency | Start Freq 2  | -                 | 49.99    | 0-60          | Hz   |
|       | 25                        | 3rd aux motor starting frequency | Start Freq 3  | -                 | 49.99    | 0-60          | Hz   |
|       | 26                        | 4th aux motor starting frequency | Start Freq 4  | -                 | 49.99    | 0-60          | Hz   |
|       | 27                        | 1st aux motor stop frequency     | Stop Freq 1   | -                 | 15.00    | 0-60          | Hz   |
|       | 28                        | 2nd aux motor stop frequency     | Stop Freq 2   | -                 | 15.00    | 0-60          | Hz   |
|       | 29                        | 3rd aux motor stop frequency     | Stop Freq 3   | -                 | 15.00    | 0-60          | Hz   |
|       | 30                        | 3th aux motor stop frequency     | Stop Freq 4   | -                 | 15.00    | 0-60          | Hz   |
|       | 31                        | Aux motor starting delay time    | Aux Start DT  | -                 | 60.0     | 0-3600.0      | Sec  |
| 32    | Aux motor stop delay time | Aux Stop DT                      | -             | 60.0              | 0-3600.0 | Sec           |      |
| APO   | 33                        | Aux motor number selection       | Num of Aux    | -                 | 4        | 0-4           | -    |
|       | 34                        | Bypass selection                 | Regul Bypass  | 0                 | No       | 0-1           | -    |
|       | 35                        | Auto change mode                 | Auto Ch Mode  | 0                 | Aux      | None/Aux/Main | -    |

| Group | Code  | Name  | LCD Display    | Parameter Setting |       | Setting Range | Unit |
|-------|-------|---|----------------|-------------------|-------|---------------|------|
|       |       | selection   |                |                   |       |               |      |
|       | 36    | Auto change time  | Auto Ch Time   | -                 | 72:00 | 0-99:00       | Min  |
|       | 38    | Interlock selection   | Interlock      | 0                 | No    | 0-1           | -    |
|       | 39    | Interlock movement delay time                                   | Interlock DT   | -                 | 5.0   | 0.1-360.0     | Sec  |
|       | 40    | Aux motor rotation pressure difference                          | Actual Pr Diff | -                 | 2     | 0-100%        | %    |
|       | 41    | Main motor acceleration time when the number of pumps decreases | Aux Acc Time   | -                 | 2.0   | 0.0-600.0     | Sec  |
|       | 42    | Main motor deceleration time when the number of pumps increases | Aux Dec Time   | -                 | 2.0   | 0.0-600.0     | Sec  |
| OUT   | 31-33 | Multi-function relay, Multi-function output 1                   | Relay x or Q1  | 24                | MMC   | -             | -    |
|       | 34-36 | Qx terminal configuration                                       | Qx Define      | 24                | MMC   | -             | -    |



### 8.38.1 Basic MMC Operation

| Code                                     | Description  |
|--|--|
| APP-01 APP Mode                          | If "3 (MMC)" is selected for the applied function, the items related to the MMC function are displayed in the option module function group (APO) and the functions related to the PID controller are displayed in APP.   |
| APO-20, 21, 33                           | If the number of auxiliary motors is set at APO-33 and there is more than one auxiliary motor, the auxiliary motor number for the first operation should be APO-21. For example, if there are three auxiliary motors and each of them is controlled by Relay 1 and 2 and the Q1 terminal, the auxiliary motors operate in the sequence of Relay 2, Q1, and then Relay 1 when "2" is input at APO-21. The auxiliary motors stop in the sequence of Relay 1, Q1, and Relay 2. At APO-20, the number of currently operating auxiliary motors can be monitored.  |
| APO-23–26 Start Freq 1–4                 | <p>Sets the starting frequency for auxiliary motors. Since the main motor is operated by the PID controller, its operating frequency is increased by the load change and the operation for an auxiliary motor becomes necessary. The conditions of the inverter output terminal I (Relay or multi-function output [Qx]) that turns on for auxiliary motor operation is as follows. The auxiliary motor can operate when</p> <ul style="list-style-type: none"> <li>• The speed of the main motor exceeds the starting frequency (APO-23–26) of the auxiliary motor.</li> <li>• The starting delay time (APO-13) of the auxiliary motor passes.</li> <li>• The difference between the reference and the feedback of the main motor PID controller becomes smaller than the pressure difference (APO-40) of the auxiliary motor motion.</li> </ul> |
| APO-27–30 Stop Freq 1–4                  | <p>Sets the stop frequency for auxiliary motors. If the operating frequency for the main motor decreases below a certain frequency while the auxiliary motor is running, the auxiliary motor should be stopped. The condition of the auxiliary motor to be stopped is as follows. The auxiliary motor can be stopped when</p> <ul style="list-style-type: none"> <li>• The speed of the main motor decreases below the stop frequency (APO-27–30) for the auxiliary motor.</li> <li>• The stop delay time (APO-32) for the auxiliary motor passes.</li> <li>• The difference between the reference and the feedback of the main motor PID controller becomes larger than the pressure difference (APO-40) of the auxiliary motor operation.</li> </ul>   |
| APO-41 Aux Acc Time, APO-42 Aux Dec Time | The main motor stops PID control and operates the normal acceleration and deceleration when the auxiliary motor runs or stops. When the auxiliary motor runs, the main motor decelerates to the decelerating frequency of the auxiliary motor for the decelerating time set at APO-42. Inversely, when the auxiliary motor stops, the main motor accelerates to the starting frequency for the accelerating time set at APO-41.  |

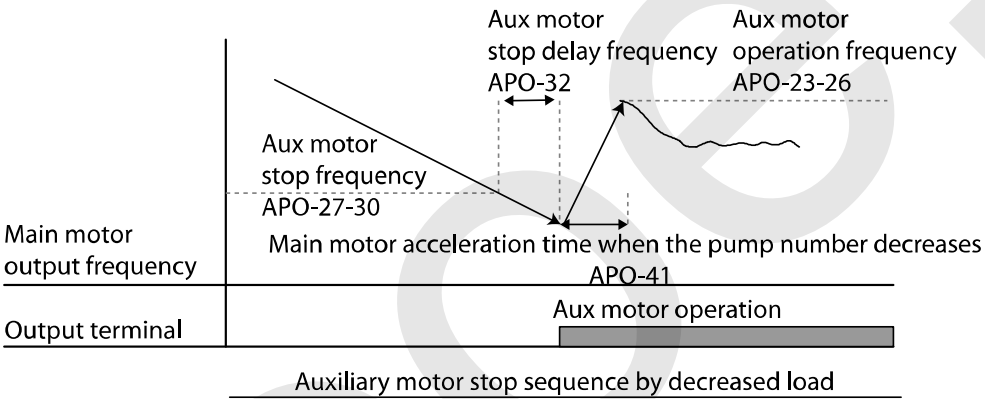
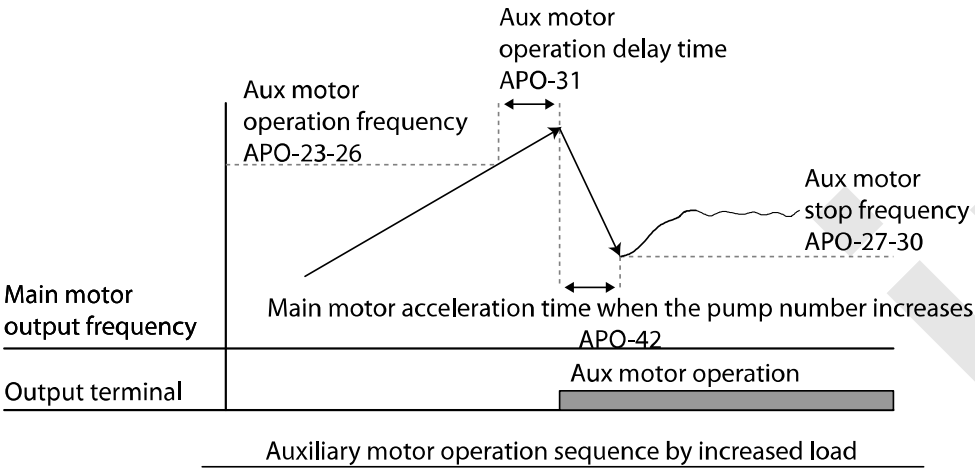

### 8.38.2 Auto Change Operation

The auto change function enables the inverter to automatically switch operations between main and auxiliary motors. Prolonged continuous operation of a motor reduces motor performance. The auto change function switches the motors automatically when certain conditions are met to avoid biased use of certain motors and protect them from deterioration.

| Code                | Description   |
|---------------------|---|
| APO-35 Auto Ch Mode | <p>Selects the motors to apply the auto change function.</p> <p><b>0: None</b><br/>The operation sequence of the auxiliary motor starts with the auxiliary motor selected at APO-21 (starting auxiliary motor selection) and the automatic change function is not active.</p> |

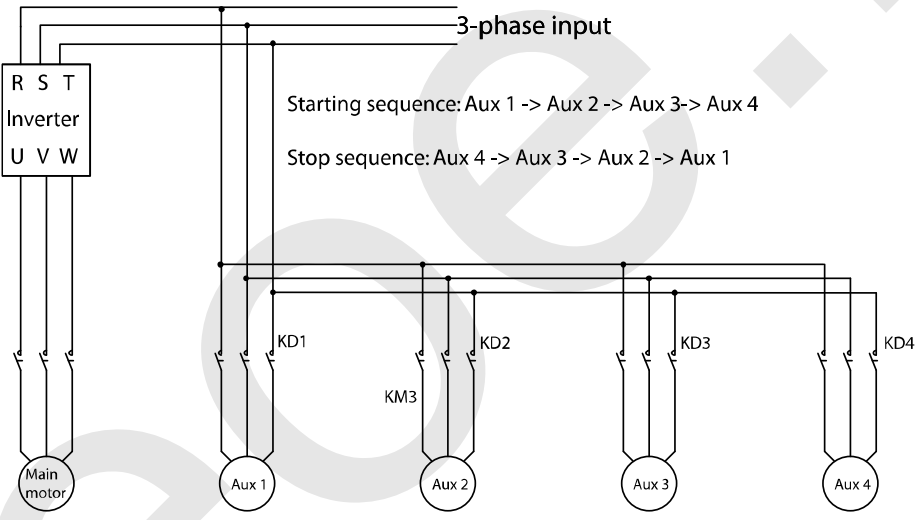
| Code | Description  |
|------|--|
|      | <p><b>1: Aux</b></p> <p>The operation sequence of the auxiliary motor starts with the auxiliary motor selected in APO-21 (starting auxiliary motor selection). When the cumulative operating time for a main and auxiliary motor exceeds the auto change time (APO-36), the auto change condition is met. If the main motor is stopped by a stop command or the sleep operation mode after the auto change condition, the start sequence of the auxiliary motor selected at APO-21 is changed.</p> <p>For example, if there are four auxiliary motors operating and motor 4 is selected in APO-21, the start sequence of the auxiliary motor automatically changes to motor 1. Therefore, the previous start sequence of the auxiliary motor of 4, 1, 2, and 3 changes to 1, 2, 3, and 4, and if the auto change condition is met, the sequence is changed to 2, 3, 4, and 1.</p>  <p>Starting sequence: Aux 1 -&gt; Aux 2 -&gt; Aux 3 -&gt; Aux 4<br/>         Stop sequence: Aux 4 -&gt; Aux 3 -&gt; Aux 2 -&gt; Aux 1</p> <p><b>2: Main</b></p> <p>Auto change is available without distinction between the main and auxiliary motors. The auto change condition is met if the cumulative operating time for the motor connected to the inverter output exceeds the auto change time (APO-36).</p> <p>If the inverter is stopped by a stop command or sleep operation mode, the operating sequence of the motor automatically changes. For example, if the starting auxiliary motor selection (APO-21) is set at "2", the inverter output is connected to motor 2. If there are four motors and the auxiliary motor operating condition is met, motors 3, 4, and 1 start operating one after another in sequence. If the inverter stops in the auto change condition, motor 3 is connected to the inverter output in the next restart and the auxiliary motors operate in the sequence of 4, 1, and 2.</p> |

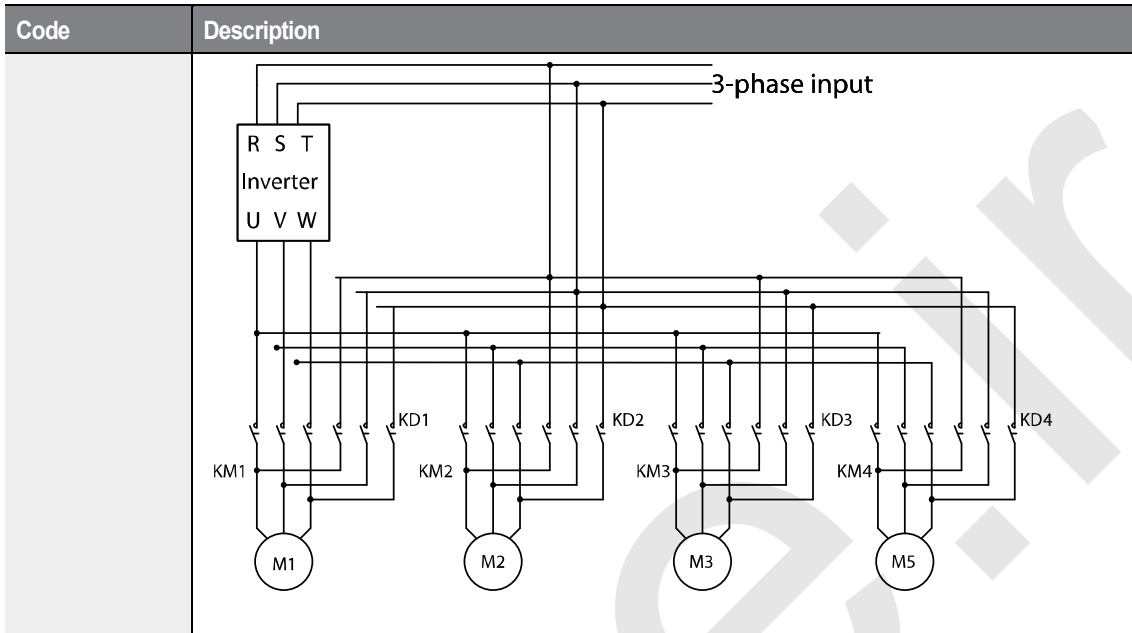

### 8.38.3 Interlock Operation

When there is motor trouble, the interlock feature is used to stop the affected motor and replace it with another that is not currently operating (i.e. in the off state). To activate the interlock feature, connect the cables to send abnormal motor signals to the inverter input terminal and configure the terminals as interlock 1–4 inputs. Then, the inverter decides the motor’s availability based on the signal inputs. The order in which the alternative motor is selected is decided based on the auto change mode selection options set at APO-35.

| Code               | Description  |
|--------------------|--|
| IN-65–75 Px Define | <p>The terminal to use as the interlock among IN 65–72 (up to 75 if there is an I/O expansion module) is selected and Interlock 1–4 are set depending on the motor sequence.</p> <p>If the auto change mode selection (APO-35) is set to “0 (None)” or “1 (Aux)” and if auxiliary motors 1, 2, and 3 are connected to inverter output terminals Relay 1, 2, and Q1 when a total of four motors including the main motor is operating, the interlock numbers 1, 2, and 3 correspond to the motor connected to Relay 1, 2, and Q1.</p> <p>However, if the auto change mode selection (APO-35) is set to “2 (Main)” and the main and auxiliary motors are connected to inverter output terminals Relay1, 2, Q1, and Q2 (I/O expansion module used) respectively, Interlock 1, 2, 3 and 4 correspond to the motors connected</p> |

| Code             | Description  |
|------------------|--|
|                  | to Relay 1, 2, Q1 and Q2.  |
| APO-38 Interlock | <p>Select "1 (Yes)" to enable an interlock operation.</p> <p><u>1) If there are five motors and the auto change mode selection (APO-35) is set to "0 (None)" or "1 (Aux)", the operation is as follows:</u></p> <p>If signals are sent to the terminal block set at Interlock 3 with a fault at motor 3 when it is static, the auxiliary motors operate in the sequence of 1, 2, and 4 (when the starting auxiliary motor selection APO-21 is "1"). If the terminal block signals are released, the operation sequence is 1, 2, 3, and 4.</p> <p>If signals are sent to the terminal for Interlock 3, auxiliary motor 3 stops and auxiliary motor 4 operates. If the interlock signal is released, auxiliary motor 4 stops and auxiliary motor 3 operates again.</p> <p><u>2) If there are four motors and the auto change mode selection (APO-35) is set to "2 (Main)", the operation is as follows:</u></p> <p>If the starting auxiliary motor selection APO-21 is set to "1", motor 1 is operated by the inverter and the remaining motors (2, 3, and 4) are operated by the auxiliary motors and interlock signals are sent to the auxiliary motors, the operation sequence is the same as the procedure described in condition 1) above.</p> <p>However, if there is a problem with motor 1, which is connected to the inverter, the output is immediately blocked and motor 2 becomes connected to the inverter output and the operation sequence of the auxiliary motor is 3 and 4. If the interlock signal of motor 1 is released, the operation sequence of the auxiliary motor is 3, 4, and 1.</p> |

### 8.38.4 Bypass Operation (Regular Bypass)

This function controls the motor speed based on the feedback amount instead of using the PID controller. Auxiliary motors may be controlled with this feature based on the feedback amount.

| Code                  | Description   |
|-----------------------|---|
| APP-34 Regular Bypass | <p>Select "1 (Yes)" to enable regular bypass.</p> <p>If there are four main motors and auxiliary motors (APP-33) in total, the operation is as follows. If the feedback input value is between 0–10 V and the operating frequency of the maximum input value (10 V) is 60 Hz, auxiliary motor 1 starts operation when the feedback amount is 2.5 V (15 Hz of main motor operating frequency).</p> <p>If the feedback amount reaches 5 V again, auxiliary motor 2 operates. At the maximum input of 10 V, all three auxiliary motors operate.</p> <p>Operation level of auxiliary motor <math>n = n * \frac{\text{Maximum feedback amount}}{\text{The number of auxiliary motor(APO - 33)}}</math></p> |

## 8.39 Press Regeneration Prevention (To evade control operation in the status of regeneration during press)

Press regeneration prevention is used during press operations to prevent braking during the regeneration process. If motor regeneration occurs during a press operation, the motor operation speed automatically goes up to avoid the regeneration zone.

| Group | Code | Name   | LCD Display    | Parameter Setting | Setting Range        | Unit |
|-------|------|--|----------------|-------------------|----------------------|------|
| ADV   | 73   | Regeneration evasion mode                                  | RegenAvd Mode  | 000-111           | 001                  | Bit  |
|       | 74   | Regeneration evasion function for press selection          | RegenAvd Sel   | 0      No         | 0-1                  | -    |
|       | 75   | Press regeneration prevention operation voltage level      | RegenAvd Level | 350               | 200 V class: 300-400 | V    |
|       |      |  |                | 700               | 400 V class: 600-800 |      |
|       | 76   | Press regeneration prevention compensation frequency limit | CompFreq Limit | 1.00              | 0-10.00              | Hz   |
|       | 77   | Press regeneration prevention P-Gain                       | RegenAvd Pgain | 50.0              | 0-100.0              | %    |
|       | 78   | Press regeneration prevention I gain                       | RegenAvd Igain | 500               | 20-30,000            | ms   |

### Press Regeneration Prevention Details

| Code   | Description  |
|--|--|
| ADV-73 RegenAvd Mode   | Set the motor operation mode to decide when the regeneration evasion function is activated.  |
| ADV-74 RegenAvd Sel (select regeneration evasion function for press) | Frequent regeneration voltage from a press load during a constant speed motor operation may put excessive stress on the braking unit, which may damage or shorten brake life. To prevent this, select ADV-74 (RegenAvd Sel) to control DC link voltage and disable the braking unit operation. |
| ADV-75 RegenAvd Level (set regeneration evasion level for press)     | Set brake operation prevention level voltage when the DC link voltage goes up due to regeneration.   |

| Code   | Description  |
|--|--|
| ADV-76 CompFreq Limit<br>(limit regeneration evasion compensation frequency for press) | Set an alternative frequency width that can replace the actual operation frequency during regeneration prevention.   |
| ADV-77 RegenAvd P gain   | Set a P gain for regeneration evasion compensation function.<br>To avoid the regeneration zone, set P-Gain in the DC link voltage suppress PI controller.  |
| ADV-78 RegenAvd I gain   | Set an I gain for regeneration evasion compensation function.<br>To avoid the regeneration zone, set I gain in the DC link voltage suppress PI controller. |

### ⚠ Caution

Press regeneration prevention does not operate during acceleration or deceleration; it only operates during constant speed motor operation. When regeneration prevention is activated, the output frequency may change within the range set at ADV-76 (CompFreq Limit).

## 8.40 Anti-Hunting Regulator

| Group | Cod e | Name  | LCD Display  | Parameter Setting |     | Setting Range | Unit |
|-------|-------|---|--------------|-------------------|-----|---------------|------|
| CON   | 90    | Function selection for preventing current hunting | New AHR Sel. | 1                 | Yes | -             | -    |
|       | 91    | Gain from current hunting prevention              | AHR P-Gain   | 1000              |     | 0-32767       | -    |

This function is used to prevent the hunting of a V/F controlled fan or motor caused by current distortion or oscillation due to mechanical resonance or other reasons. You can set the hunting prevention function (CON-90) to prevent current hunting.

**CON-91 AHR P-Gain:** Increasing AHR proportional gain improves the responsiveness of the anti-hunting regulation. However, current oscillation may result if AHR proportional gain is set too high.



## 8.41 Fire Mode

This function is used to allow the inverter to ignore minor faults during emergency situations, such as fire, and provides continuous operation to protect other systems, such as ventilation fans. When fire mode is activated, the inverter operates continuously based on the set frequency and direction.

| Group | Code              | Name                          | LCD Display    | Parameter Setting |           | Setting range | Unit |
|-------|-------------------|-------------------------------|----------------|-------------------|-----------|---------------|------|
| ADV   | 80                | Fire mode selection           | Fire Mode Sel  | 0                 | None      | 0–2           | -    |
|       |                   |                               |                | 1                 | Fire Mode |               | -    |
|       |                   |                               |                | 2                 | Fire Test |               | -    |
|       | 81                | Fire mode frequency           | Fire Mode Freq | 60.00             |           |               | Hz   |
|       | 82                | Fire mode operating direction | Fire Mode Dir  | 0                 | Forward   | 0–1           | -    |
| 1     |                   |                               |                | Reverse           | -         |               |      |
| 83    | Fire mode counter | Fire Mode Cnt                 | 0              |                   | -         | -             |      |
| IN    | 65–75             | Px terminal configuration     | Px Define      | 51                |           | -             | -    |
| OUT   | 31–33             | Relay1,2 and Q1               | Relay1,2 / Q1  | 37                |           | -             | -    |

### Fire Mode Details

| Code                  | Description   |
|-----------------------|---|
| ADV-80 Fire Mode Sel  | When you select function 1-Fire Mode, ADV-81–83 is displayed. In the above settings, if “51 (Fire Mode)” in IN-65–75 is on, fire mode operates. During the fire mode operation status, a “fire mode” warning occurs. During fire mode operation, the inverter’s frequency and operation direction is performed in the value set for fire mode with the previously set control mode. |
| ADV-81 Fire Mode Freq | Set the operation frequency for fire mode.  |
| ADV-82 Fire Mode Dir  | Set the run direction for fire mode operation.  |
| ADV-80 Fire Mode Sel  | If the mode is set to “2-Fire Test”, related items for the fire function (ADV-81–83) are displayed. In the above settings, if “51 (Fire Mode)” in IN-65–75 is on, fire mode operates. The basic operation is the same as fire mode. However,  |

| Code | Description   |
|------|---|
|      | ADV-83 is not counted in fire test mode. Also, all fault trips occur without ignoring them. |

If a fault occurs during fire mode operation, the fault trip is ignored and the inverter continuously operates. However, if a critical fault occurs, the inverter performs the trip operation or auto restart operation. The auto restart is performed after PRT-10 Retry Delay is set.

If the inverter performs the fire mode operation when the inverter is in normal status after the auto restart, the inverter will operate via the speed search.

Fire mode cannot be set while in torque mode. Therefore, fire mode can only be set when the inverter is in speed or operation mode.

In fire mode, the operation for fault trips is listed in the following table.

| Operation in the event of fault trips | Fault trips  |
|---------------------------------------|--|
| Fault trips that are ignored          | Low Voltage , Over Load, Under Load, Inverter OLT, E-Thermal, Out Phase Open, In Phase Open, Over Speed, Speed Dev Trip, NTC Open, Over Heat, Fuse Open, Thermal Trip, Fan Trip, BX, Lost Command, Lost Keypad, Low Voltage2, etc. |
| Auto restart after fault trips        | Ground Trip, Over Current1, Over Voltage   |
| Trip operation                        | H/W-Diag, Over Current2, Safety Opt Err  |

### ⚠ Caution

Fire mode operation voids the product warranty. To test fire mode not to increase the fire mode operation count at ADV-83, set ADV-80 to “2-Fire Test” and operate the inverter.

If the multi-function terminal input set to “51 (Fire Mode)” is on when ADV-83 is set to “1 (Fire Mode)”, the count value set at ADV-83 is increased by 1.

## 8.42 Dynamic Braking (DB) Resistor Operation Reference Voltage

Depending on the capacity, the iS7 series is divided into models with a braking resistor circuit integrated inside the inverter, and models that require an external braking unit to be installed. The inverters rated between 0.75–22 kW have the built-in braking model (except for the braking resistor), and the inverters rated above 30 kW require an external braking unit. Therefore, the reference voltage setting function for the braking resistor is necessary for inverters rated below 22 kW.

| Group | Code | Name                      | LCD Display    | Parameter Setting | Setting Range         | Unit |
|-------|------|---------------------------|----------------|-------------------|-----------------------|------|
| ADV   | 79   | DB unit operating voltage | DB Turn On Lev | 390 V             | 200 V Type: 350–400 V | V    |
|       |      |                           |                | 780 V             | 400 V Type: 600–800 V |      |

**ADV-79 DB Turn On Lev:** This is the operation reference voltage for the braking resistor. The braking resistor operates when the DC link voltage exceeds the reference value.

The initial value for 200 V-type inverters is 390 V, and the initial value for 400 V-type inverters is 780 V.

For 200 V-type inverters, the reference voltage that stops the braking resistor is 10 V lower than the operating voltage set at ADV-79. For 400 V-type inverters, the braking resistor stops if the voltage is 20 V lower than the operating voltage set at ADV-79.

### ⚠ Caution

If the set value for ADV-79 is lower than the DC link voltage when the inverter is in normal operation, the DB resistor may overheat due to continuous DB resistor operation.

Conversely, if the set value at ADV-79 is much higher than the DC link voltage range, an overvoltage trip may occur because the DB resistor does not operate when it is needed.

Example) If the input voltage is 440 V and the value at ADV-79 is set to 600 V, the DB resistor operates when the inverter is on because the DC link voltage is 622 V. Since the voltage level that stops the DB resistor is 590 V, the DB resistor may overheat due to continuous DB resistor operation.

## 8.43 kW/HP Unit Selection

Select the units between kW and HP for the capacity of the inverter and motor.

| Group | Code | Name                 | LCD Display  | Parameter Setting | Setting Range | Unit |
|-------|------|----------------------|--------------|-------------------|---------------|------|
| DRV   | 30   | kW/HP unit selection | KW/HP Select | 0                 | 0-1           | -    |
|       |      |                      |              | 1                 |               |      |

## 8.44 Output Voltage Drop Prevention

This function is used to prevent voltage drop in the inverter output by decreasing the current output, thereby taking advantage of the expanded command zone of the output voltage, if the input voltage drops or overload conditions arise.

| Group | Code | Name               | LCD Display  | Parameter Setting |     | Setting Range | Initial |
|-------|------|--------------------|--------------|-------------------|-----|---------------|---------|
| ADV   | 87   | OVM Mode selection | OVM Mode Sel | 0                 | No  | 0-1           | 0:No    |
|       |      |                    |              | 1                 | Yes |               |         |

This function is used to prevent voltage drop in the inverter output by decreasing the current output, thereby taking advantage of the expanded command zone of the output voltage, if the input voltage drops or overload conditions arise. Set ADV-87 (OVM Mode Sel) to "0 (No)" to limit the voltage output command zone for linear voltage output. Set ADV-87 (OVM Mode Sel) to "1 (Yes)" to expand the voltage output command zone and ensure stable voltage output is made throughout the overmodulated zone.

### Caution



- **When you enable the OVM Mode, the output wave may be distorted because it will not be maintained in a linear form.**
- **Also, a higher voltage than the motor's rated voltage may be output to the motor if the input voltage is higher than the motor's rated voltage.**
- **Although the current may appear to be rapidly oscillating during high-speed operation, the actual change in the output current is not severe.**
- **The output voltage will be compensated for to stay below the rated voltage of the motor according to the parameter setting.**
- **The OVM Mode will not be activated if the input voltage is higher than the output voltage.**

## 9 Using Monitor Functions

### 9.1 Monitoring the Operating Status via the Keypad

You can monitor the operating status using the keypad of the inverter. You can select the desired items to monitor in Config mode (CNF), view three items at a time in Monitor mode, and select an item on the status display.

#### 9.1.1 Selecting Monitor Mode Display

| Mode | Group | Code | LCD Display    | Parameter Setting |                | Unit |
|------|-------|------|----------------|-------------------|----------------|------|
| CNF  | -     | 21   | Monitor Line-1 | 0                 | Frequency      | Hz   |
|      | -     | 22   | Monitor Line-2 | 2                 | Output Current | A    |
|      | -     | 23   | Monitor Line-3 | 3                 | Output Voltage | V    |
|      |       | 24   | Mon Mode Init  | 0                 | No             | -    |

#### Monitor Mode Display Selection Details

| Code                        | Description   |   |   |   |           |   |   |       |   |   |                |                              |   |                |                              |   |              |                            |   |               |  |   |                |  |   |           |   |   |           |  |
|-----------------------------|---|---|---|---|-----------|---|---|-------|---|---|----------------|------------------------------|---|----------------|------------------------------|---|--------------|----------------------------|---|---------------|--|---|----------------|--|---|-----------|---|---|-----------|--|
| CNF-21–23<br>Monitor Line-x | Select the items to monitor in Monitor mode. Monitor mode is displayed when the inverter is powered on. Also, all three items in Monitor Line-1–3 can be displayed simultaneously. Select an item for the line to display. If “Yes” is set at CNF-24 (Mon Mode Init), CNF-21–23 will be initialized.  |   |   |   |           |   |   |       |   |   |                |                              |   |                |                              |   |              |                            |   |               |  |   |                |  |   |           |   |   |           |  |
|                             | <table border="1"> <thead> <tr> <th>Setting</th> <th>Function</th> </tr> </thead> <tbody> <tr> <td>0</td> <td>Frequency</td> <td>Displays the set frequency while stopped. During operation, it displays the actual output frequency (Hz).</td> </tr> <tr> <td>1</td> <td>Speed</td> <td>Displays the set speed (rpm) while stopped. During operation, it displays the actual operating speed (rpm).</td> </tr> <tr> <td>2</td> <td>Output Current</td> <td>Displays the output current.</td> </tr> <tr> <td>3</td> <td>Output Voltage</td> <td>Displays the output voltage.</td> </tr> <tr> <td>4</td> <td>Output Power</td> <td>Displays the output power.</td> </tr> <tr> <td>5</td> <td>WHour Counter</td> <td>Displays the inverter’s power consumption.</td> </tr> <tr> <td>6</td> <td>DCLink Voltage</td> <td>Displays the inverter’s DC link voltage.</td> </tr> <tr> <td>7</td> <td>DI Status</td> <td>Displays the input terminal status of the terminal block. Starting from the right, it displays P1–P8.</td> </tr> <tr> <td>8</td> <td>DO Status</td> <td>Displays the output terminal status of the terminal block.</td> </tr> </tbody> </table> | Setting   | Function  | 0 | Frequency | Displays the set frequency while stopped. During operation, it displays the actual output frequency (Hz). | 1 | Speed | Displays the set speed (rpm) while stopped. During operation, it displays the actual operating speed (rpm). | 2 | Output Current | Displays the output current. | 3 | Output Voltage | Displays the output voltage. | 4 | Output Power | Displays the output power. | 5 | WHour Counter | Displays the inverter’s power consumption. | 6 | DCLink Voltage | Displays the inverter’s DC link voltage. | 7 | DI Status | Displays the input terminal status of the terminal block. Starting from the right, it displays P1–P8. | 8 | DO Status | Displays the output terminal status of the terminal block. |
|                             | Setting   | Function  |   |   |           |   |   |       |   |   |                |                              |   |                |                              |   |              |                            |   |               |  |   |                |  |   |           |   |   |           |  |
|                             | 0   | Frequency   | Displays the set frequency while stopped. During operation, it displays the actual output frequency (Hz).   |   |           |   |   |       |   |   |                |                              |   |                |                              |   |              |                            |   |               |  |   |                |  |   |           |   |   |           |  |
|                             | 1   | Speed   | Displays the set speed (rpm) while stopped. During operation, it displays the actual operating speed (rpm). |   |           |   |   |       |   |   |                |                              |   |                |                              |   |              |                            |   |               |  |   |                |  |   |           |   |   |           |  |
|                             | 2   | Output Current  | Displays the output current.  |   |           |   |   |       |   |   |                |                              |   |                |                              |   |              |                            |   |               |  |   |                |  |   |           |   |   |           |  |
|                             | 3   | Output Voltage  | Displays the output voltage.  |   |           |   |   |       |   |   |                |                              |   |                |                              |   |              |                            |   |               |  |   |                |  |   |           |   |   |           |  |
|                             | 4   | Output Power  | Displays the output power.  |   |           |   |   |       |   |   |                |                              |   |                |                              |   |              |                            |   |               |  |   |                |  |   |           |   |   |           |  |
|                             | 5   | WHour Counter   | Displays the inverter’s power consumption.  |   |           |   |   |       |   |   |                |                              |   |                |                              |   |              |                            |   |               |  |   |                |  |   |           |   |   |           |  |
|                             | 6   | DCLink Voltage  | Displays the inverter’s DC link voltage.  |   |           |   |   |       |   |   |                |                              |   |                |                              |   |              |                            |   |               |  |   |                |  |   |           |   |   |           |  |
| 7                           | DI Status   | Displays the input terminal status of the terminal block. Starting from the right, it displays P1–P8. |   |   |           |   |   |       |   |   |                |                              |   |                |                              |   |              |                            |   |               |  |   |                |  |   |           |   |   |           |  |
| 8                           | DO Status   | Displays the output terminal status of the terminal block.  |   |   |           |   |   |       |   |   |                |                              |   |                |                              |   |              |                            |   |               |  |   |                |  |   |           |   |   |           |  |

| Code | Description   |
|------|---|
|      | Starting from the right, it displays Relay1, Relay2, and Q1.  |
| 9    | V1 Monitor[V]<br>Displays the input voltage value at terminal V1 (V).   |
| 10   | V1 Monitor[%]<br>Displays the input voltage terminal V1 value as a percentage. If -10V, 0V, and +10V is measured, -100%, 0%, and 100% will be displayed.  |
| 11   | I1 Monitor[mA]<br>Displays the magnitude of the current being input to the I1 terminal of the inverter terminal block.  |
| 12   | I1 Monitor[%]<br>Displays the above current as a percent. If the input current is 0–20[mA], it is shown as 0–100%.  |
| 13   | V2 Monitor[V]<br>Displays the voltage input of the I/O expansion module's V2 terminal when using the I/O expansion module.  |
| 14   | V2 Monitor[%]<br>Displays the V2 input voltage as a percent.  |
| 15   | I2 Monitor[mA]<br>Displays the current input for the I/O expansion module's I2 terminal when using the I/O expansion module.  |
| 16   | I2 Monitor[%]<br>Displays the I2 input current terminal value as a percentage.  |
| 17   | PID Output<br>Displays the PID controller's output.   |
| 18   | PID Ref Value<br>Displays the PID controller's reference value.   |
| 19   | PID Fdb Value<br>Displays the PID controller's feedback volume.   |
| 20   | Torque<br>Displays the torque reference value if torque reference command mode (DRV-08) is set to a value other than "Keypad" (0 or 1).   |
| 21   | Torque Limit<br>Displays the torque limit value if the torque limit setting method (CON-53) is set to a value other than "Keypad" (0 or 1).   |
| 22   | Trq Bias Ref<br>Displays the torque bias if the torque bias setting method (CON-58) is set to a value other than "Keypad" (0 or 1).   |
| 23   | Spd Limit<br>Displays the speed limit setting If the speed limiting (CON-62) in Torque Control mode is set to a value other than "Keypad" (0 or 1).   |
| 24   | Load Speed<br>Displays the load speed in the desired scale and unit. Displays the load speed as values which are applied in the units of rpm or mpm set in ADV-63 (Load Spd Unit), ADV-61 (Load Spd Gain), and ADV-62 (Load Spd Scale). |
| 25   | Temperature<br>Displays the inverter's internal temperature.  |

## 9.1.2 Displaying Output Power

| Mode | Group | Code | LCD Display  | Parameter Setting |       | Unit |
|------|-------|------|--------------|-------------------|-------|------|
| PAR  | BAS   | 18   | Trim Power % | -                 | 100.0 | %    |

When CNF-21–23 (Monitor Line-x Select) is set to “4 (Output Power)”, increase the set value at BAS-18 (Trim Power) appropriately if the output power displayed on the keypad is lower than expected.

If the output power displayed on the keypad is higher than expected, decrease this set value accordingly. The output power display is calculated using voltage and current. However, an output power error may occur when the power factor is low.

### Note

#### WHour Counter (Inverter power consumption)

Values are calculated using voltage and current. Electric power is calculated every second and the results are accumulated.

Power consumption is displayed as follows:

- Less than 1,000 kW: Units are in kW, displayed in a 999.9 kW format.
- 1–99 MW: Units are in MW, displayed in a 99.99 MWh format.
- 100–999 MW: Units are in MW, displayed in a 999.9 MWh format.
- More than 1,000 MW: Units are in MW, displayed in 9,999 MWh format and can be displayed up to 65,535 MW. (Values exceeding 65,535 MW will reset the value to 0 and units will return to kW. It will be displayed in a 999.9 kW format).
- If the WH CNF-62 (Count Reset) is set to “YES,” you can clear the electricity consumption.

### 9.1.3 Selecting Load Speed Display

| Mode | Group | Code | LCD Display    | Parameter Setting |       | Unit |
|------|-------|------|----------------|-------------------|-------|------|
| PAR  | ADV   | 61   | Load Spd Gain  | -                 | 100.0 | %    |
|      |       | 62   | Load Spd Scale | 0                 | X 1   | -    |
|      |       | 63   | Load Spd Unit  | 0                 | rpm   | -    |

#### Load Speed Display Details

Set CNF-21–23 (Monitor Line-x Select) to “24 (Load Speed)”, and adjust the following codes to display load speed.

| Code                  | Description  |
|-----------------------|--|
| ADV-61 Load Spd Gain  | Sets the gear ratio in a percentage for speed conversion. When the ratio is set, the actual number of rotations of the other axis or gear system that is connected to the motor is displayed accordingly.<br>For example, set ADV-61 (Load Spd Gain) to 30.0%, if the flux value is 300 [mpm] at 1000 [rpm]. |
| ADV-62 Load Spd Scale | Selects to what decimal place to display at “24 (Load Speed)” among the monitor items (x1-x0.0001). If you want to display the value to one decimal place, set ADV-63 (Load Spd Scale) to X 0.1.   |
| ADV-63 Load Spd Unit  | Selects the unit of “24 (Load Speed)” from the monitor items. Also, select either RPM (Revolutions Per Minute) or MPM (Meters Per Minute).   |

### 9.1.4 Selecting Hz/Rpm Display

You can convert all the parameters with a Hz unit into RPM or vice versa. The pole number (BAS-11) must be entered for the conversion.

| Mode | Group | Code | LCD Display | Parameter Setting |    | Unit |
|------|-------|------|-------------|-------------------|----|------|
| PAR  | DRV   | 21   | Hz/Rpm Sel  | 0                 | Hz | -    |
|      | BAS   | 11   | Pole Number | -                 | 4  | -    |

#### Warning

If you change the default set value at DRV-21 (Hz/RPM Sel) from “Hz” to “RPM”, all parameters except the ones set for the monitor mode will be changed to RPM. To change the speed unit from frequency to speed in Monitor mode, change the parameter value at CNF-21.



### 9.1.5 Selecting Status Display

| Mode | Code | LCD Display  | Parameter Setting |           | Unit |
|------|------|--------------|-------------------|-----------|------|
| CNF  | 20   | AnyTime Para | 0                 | Frequency | -    |

#### Status Display Selection Details

| Code                | Description   |                |            |                |          |   |           |    |               |   |       |    |               |   |                |    |                |   |                |    |               |   |              |    |            |   |               |    |               |   |                |    |               |   |   |    |        |   |   |    |              |   |               |    |              |    |               |    |             |    |                |    |            |    |               |  |  |
|---------------------|---|----------------|------------|----------------|----------|---|-----------|----|---------------|---|-------|----|---------------|---|----------------|----|----------------|---|----------------|----|---------------|---|--------------|----|------------|---|---------------|----|---------------|---|----------------|----|---------------|---|---|----|--------|---|---|----|--------------|---|---------------|----|--------------|----|---------------|----|-------------|----|----------------|----|------------|----|---------------|--|--|
| CNF-20 AnyTime Para | Select the variables to be displayed at the top of Keypad display (LCD display).  |                |            |                |          |   |           |    |               |   |       |    |               |   |                |    |                |   |                |    |               |   |              |    |            |   |               |    |               |   |                |    |               |   |   |    |        |   |   |    |              |   |               |    |              |    |               |    |             |    |                |    |            |    |               |  |  |
|                     | <table border="1"> <thead> <tr> <th>Setting</th> <th>Function</th> <th>Setting</th> <th>Function</th> </tr> </thead> <tbody> <tr> <td>0</td> <td>Frequency</td> <td>13</td> <td>V2 Monitor[V]</td> </tr> <tr> <td>1</td> <td>Speed</td> <td>14</td> <td>V2 Monitor[%]</td> </tr> <tr> <td>2</td> <td>Output Current</td> <td>15</td> <td>I2 Monitor[mA]</td> </tr> <tr> <td>3</td> <td>Output Voltage</td> <td>16</td> <td>I2 Monitor[%]</td> </tr> <tr> <td>4</td> <td>Output Power</td> <td>17</td> <td>PID Output</td> </tr> <tr> <td>5</td> <td>WHour Counter</td> <td>18</td> <td>PID Ref Value</td> </tr> <tr> <td>6</td> <td>DCLink Voltage</td> <td>19</td> <td>PID Fdb Value</td> </tr> <tr> <td>7</td> <td>-</td> <td>20</td> <td>Torque</td> </tr> <tr> <td>8</td> <td>-</td> <td>21</td> <td>Torque Limit</td> </tr> <tr> <td>9</td> <td>V1 Monitor[V]</td> <td>22</td> <td>Trq Bias Ref</td> </tr> <tr> <td>10</td> <td>V1 Monitor[%]</td> <td>23</td> <td>Speed Limit</td> </tr> <tr> <td>11</td> <td>I1 Monitor[mA]</td> <td>24</td> <td>Load Speed</td> </tr> <tr> <td>12</td> <td>I1 Monitor[%]</td> <td></td> <td></td> </tr> </tbody> </table> | Setting        | Function   | Setting        | Function | 0 | Frequency | 13 | V2 Monitor[V] | 1 | Speed | 14 | V2 Monitor[%] | 2 | Output Current | 15 | I2 Monitor[mA] | 3 | Output Voltage | 16 | I2 Monitor[%] | 4 | Output Power | 17 | PID Output | 5 | WHour Counter | 18 | PID Ref Value | 6 | DCLink Voltage | 19 | PID Fdb Value | 7 | - | 20 | Torque | 8 | - | 21 | Torque Limit | 9 | V1 Monitor[V] | 22 | Trq Bias Ref | 10 | V1 Monitor[%] | 23 | Speed Limit | 11 | I1 Monitor[mA] | 24 | Load Speed | 12 | I1 Monitor[%] |  |  |
|                     | Setting   | Function       | Setting    | Function       |          |   |           |    |               |   |       |    |               |   |                |    |                |   |                |    |               |   |              |    |            |   |               |    |               |   |                |    |               |   |   |    |        |   |   |    |              |   |               |    |              |    |               |    |             |    |                |    |            |    |               |  |  |
|                     | 0   | Frequency      | 13         | V2 Monitor[V]  |          |   |           |    |               |   |       |    |               |   |                |    |                |   |                |    |               |   |              |    |            |   |               |    |               |   |                |    |               |   |   |    |        |   |   |    |              |   |               |    |              |    |               |    |             |    |                |    |            |    |               |  |  |
|                     | 1   | Speed          | 14         | V2 Monitor[%]  |          |   |           |    |               |   |       |    |               |   |                |    |                |   |                |    |               |   |              |    |            |   |               |    |               |   |                |    |               |   |   |    |        |   |   |    |              |   |               |    |              |    |               |    |             |    |                |    |            |    |               |  |  |
|                     | 2   | Output Current | 15         | I2 Monitor[mA] |          |   |           |    |               |   |       |    |               |   |                |    |                |   |                |    |               |   |              |    |            |   |               |    |               |   |                |    |               |   |   |    |        |   |   |    |              |   |               |    |              |    |               |    |             |    |                |    |            |    |               |  |  |
|                     | 3   | Output Voltage | 16         | I2 Monitor[%]  |          |   |           |    |               |   |       |    |               |   |                |    |                |   |                |    |               |   |              |    |            |   |               |    |               |   |                |    |               |   |   |    |        |   |   |    |              |   |               |    |              |    |               |    |             |    |                |    |            |    |               |  |  |
|                     | 4   | Output Power   | 17         | PID Output     |          |   |           |    |               |   |       |    |               |   |                |    |                |   |                |    |               |   |              |    |            |   |               |    |               |   |                |    |               |   |   |    |        |   |   |    |              |   |               |    |              |    |               |    |             |    |                |    |            |    |               |  |  |
|                     | 5   | WHour Counter  | 18         | PID Ref Value  |          |   |           |    |               |   |       |    |               |   |                |    |                |   |                |    |               |   |              |    |            |   |               |    |               |   |                |    |               |   |   |    |        |   |   |    |              |   |               |    |              |    |               |    |             |    |                |    |            |    |               |  |  |
|                     | 6   | DCLink Voltage | 19         | PID Fdb Value  |          |   |           |    |               |   |       |    |               |   |                |    |                |   |                |    |               |   |              |    |            |   |               |    |               |   |                |    |               |   |   |    |        |   |   |    |              |   |               |    |              |    |               |    |             |    |                |    |            |    |               |  |  |
|                     | 7   | -              | 20         | Torque         |          |   |           |    |               |   |       |    |               |   |                |    |                |   |                |    |               |   |              |    |            |   |               |    |               |   |                |    |               |   |   |    |        |   |   |    |              |   |               |    |              |    |               |    |             |    |                |    |            |    |               |  |  |
|                     | 8   | -              | 21         | Torque Limit   |          |   |           |    |               |   |       |    |               |   |                |    |                |   |                |    |               |   |              |    |            |   |               |    |               |   |                |    |               |   |   |    |        |   |   |    |              |   |               |    |              |    |               |    |             |    |                |    |            |    |               |  |  |
|                     | 9   | V1 Monitor[V]  | 22         | Trq Bias Ref   |          |   |           |    |               |   |       |    |               |   |                |    |                |   |                |    |               |   |              |    |            |   |               |    |               |   |                |    |               |   |   |    |        |   |   |    |              |   |               |    |              |    |               |    |             |    |                |    |            |    |               |  |  |
|                     | 10  | V1 Monitor[%]  | 23         | Speed Limit    |          |   |           |    |               |   |       |    |               |   |                |    |                |   |                |    |               |   |              |    |            |   |               |    |               |   |                |    |               |   |   |    |        |   |   |    |              |   |               |    |              |    |               |    |             |    |                |    |            |    |               |  |  |
| 11                  | I1 Monitor[mA]  | 24             | Load Speed |                |          |   |           |    |               |   |       |    |               |   |                |    |                |   |                |    |               |   |              |    |            |   |               |    |               |   |                |    |               |   |   |    |        |   |   |    |              |   |               |    |              |    |               |    |             |    |                |    |            |    |               |  |  |
| 12                  | I1 Monitor[%]   |                |            |                |          |   |           |    |               |   |       |    |               |   |                |    |                |   |                |    |               |   |              |    |            |   |               |    |               |   |                |    |               |   |   |    |        |   |   |    |              |   |               |    |              |    |               |    |             |    |                |    |            |    |               |  |  |

### 9.1.6 Monitoring Output Frequency

Select DRV-25 to monitor output frequency. Output frequency is displayed in 0.01[Hz] increments. The output frequency is displayed as 0.00[Hz] when the inverter is not operating.

| Group | Code | LCD Display | Parameter Setting |      | Unit |
|-------|------|-------------|-------------------|------|------|
| DRV   | 25   | Output Freq | -                 | 0.00 | Hz   |

## 9.2 Monitoring Fault Status Using Keypad

Trip mode displays the fault status when a fault trip occurs during inverter operation. You can monitor the fault types, operating frequency, and output current at the time of fault trip. Up to the last 5 fault trips can be saved.

### 9.2.1 Monitoring Current Fault Status

When a fault trip occurs, the fault type is displayed on the keypad's display.

|                          |          |
|--------------------------|----------|
| TRP Current              |          |
| <b>Over Voltage (02)</b> |          |
| 01 Output Freq           | 35.10 Hz |
| 02 Output Current        | 15.5 A   |

For more details on types and descriptions of fault trips, refer to [12.2 Warning Messages](#) on page 373. The following operating status can be monitored and recorded.

| Displayed Information | Description  |
|-----------------------|--|
| 1 Output Freq         | Displays the operating frequency at the time of the fault trip.                |
| 2 Output Current      | Displays the output current at the time of the fault trip.                     |
| 3 Inverter State      | Displays acceleration, deceleration, constant speed operation, and stop state. |
| 4 DCLink Voltage      | Displays the inverter's DC power voltage.                                      |
| 5 Temperature         | Displays the inverter's temperature.   |
| 6 Input State         | Displays the input terminal's status.  |
| 7 Output State        | Displays the output terminal's status.   |
| 8 Trip On Time        | Displays the time from the power ON to the fault trip.                         |
| 9 Trip Run Time       | Displays the time from Run to the fault trip.                                  |

If you press the [STOP/RESET] key on the keypad or input the reset terminal of the terminal block to release the fault trip, the information for the currently displayed fault trip is saved as part of the fault trip history. In this case, what was saved in the Fault Trip History 1 (Last-1) is moved to the Failure History 2 (Last-2).

The number next to the fault trip name represents the number of simultaneously occurring faults. If more than one fault occurred, you can press the [PROG/ENT] key to view the other faults.

## 9.2.2 Monitoring Fault Trip History

The types of up to five previous fault trips can be saved and monitored. The lower the number of Last X is, the more recent the fault it represents. If more than 5 faults occur, those occurring before the last 5 are automatically deleted.

The items displayed in the fault trip history are listed in the following table.

| Displayed Information |                | Description  |
|-----------------------|----------------|--|
| 0                     | Trip Names(1)  | Displays the fault types.  |
| 1                     | Output Freq    | The operating frequency at the time of the fault occurrence.                   |
| 2                     | Output Current | The output current at the time of the fault occurrence.                        |
| 3                     | Inverter State | Displays acceleration, deceleration, constant speed operation, and stop state. |
| 4                     | DCLink Voltage | Displays the inverter's DC power voltage.                                      |
| 5                     | Temperature    | Displays the inverter's temperature.   |
| 6                     | Input State    | Displays the input terminal's status.  |
| 7                     | Output State   | Displays the output terminal's status.   |
| 8                     | Trip On Time   | Displays the time from the power ON to the fault occurrence.                   |
| 9                     | Trip Run Time  | Displays the time from Run to the fault occurrence.                            |
| 10                    | Trip Delete ?  | Displays whether the currently saved fault trip history is to be deleted.      |

There are two ways to delete the fault trip history.

At each fault trip, To delete the individual fault trip, select "Yes" at TRP-10 (Trip Delete?). Also, to delete the entire fault trip history, select "Yes" at CNF-24 (Erase All Trip).

## 9.3 Analog output

### 9.3.1 Voltage Output (0–10 V)

Select the items to be output from AO1 (Analog Output 1) terminal of the inverter terminal block and adjust the output sizes.

| Group | Code | LCD Display | Parameter Setting |           | Unit |
|-------|------|-------------|-------------------|-----------|------|
| OUT   | 01   | AO1 Mode    | 0                 | Frequency | -    |
|       | 02   | AO1 Gain    | -                 | 100.0     | %    |
|       | 03   | AO1 Bias    | -                 | 0.0       | %    |
|       | 04   | AO1 Filter  | -                 | 5         | ms   |
|       | 05   | AO1 Const % | -                 | 0.0       | %    |
|       | 06   | AO1 Monitor | -                 | 0.0       | %    |

#### Voltage Output Setting Details

| Code            | Description              |  |  |
|-----------------|--------------------------|--|--|
| OUT-01 AO1 Mode | Select the output types. |  |  |
|                 | Setting                  | Description  |  |
|                 | 0                        | Frequency  | Outputs an operation frequency as the standard. A 10 V output is supplied based on the frequency set at DRV-20 (Max Freq).   |
|                 | 1                        | Output Current   | A 10 V output is supplied from 200% of the inverter-rated current (based on CT: Constant Torque).  |
|                 | 2                        | Output Voltage   | Sets the outputs based on the inverter output voltage. A 10 V output is supplied from the voltage set at BAS-15 (Rated V). If 0 V is set at BAS-15, 200 V/400 V models output 10 V based on the actual input voltage (220 V and 440 V respectively). |
|                 | 3                        | DC Link Volt   | Outputs the inverter DC link voltage as the standard. Outputs 10 V when the DC link voltage is 410 VDC for 200 V models, and 820 VDC for 400 V models.   |
|                 | 4                        | Torque   | Outputs the generated torque as the standard. Outputs 10 V at 250% of the motor-rated torque.  |
|                 | 5                        | Output Power   | Monitors the output wattage. 200% of the rated output is the maximum display voltage (10 V).   |
|                 | 6                        | Idse   | Outputs the maximum voltage at 200% of the no load current.  |
| 7               | Iqse                     | Outputs the maximum voltage at 250% of the rated torque current.<br>Rated torque current = $\sqrt{\text{rated current}^2 - \text{Non-load current}^2}$ |  |

| Code | Description   |  |
|------|---------------|--|
| 8    | Target Freq   | Outputs the set frequency as the standard. Outputs 10 V at the maximum frequency (DRV-20).   |
| 9    | Ramp Freq     | Outputs frequency calculated with Acc/Dec function as a standard. This may vary depending on the actual output frequency. Outputs 10 V.  |
| 10   | Speed Fdb     | Displays the speed information of the input into the encoder extension module. It produces 10 V at the maximum frequency (DRV-20).   |
| 11   | Speed Dev     | Outputs the difference between the speed reference (command) and the motor's rotation speed that inputs into the encoder extension module. It outputs 10 V at twice the rated slip frequency. It is valid only in Vector Control mode. |
| 12   | PID Ref Value | Outputs command value of a PID controller as the standard. Outputs approximately 6.6 V at 100%.  |
| 13   | PID Fdb Value | Outputs feedback volume of a PID controller as the standard. Outputs approximately 6.6 V at 100%.  |
| 14   | PID Output    | Outputs the output value of a PID controller as the standard. Outputs approximately 10 V at 100%.  |
| 15   | Constant      | Outputs the OUT-05 (AO1 Const %) value as a standard.  |

Adjusts output value and offset. If frequency is selected as an output item, it will operate as shown below.

$$AO1 = \frac{Frequency}{MaxFreq} \times AO1Gain + AO1Bias$$

The graph below illustrates how the analog voltage output (AO1) changes depending on OUT-02 (AO1 Gain) and OUT-3 (AO1 Bias) values. The Y-axis is analog output voltage (0–10 V), and the X-axis is a % value of the output item.

Example, if the maximum frequency set at DRV-20 (Max Freq) is 60 Hz and the present output frequency is 30 Hz, then the x-axis value on the next graph is 50%.

OUT-02 AO1 Gain,  
OUT-03 AO1 Bias

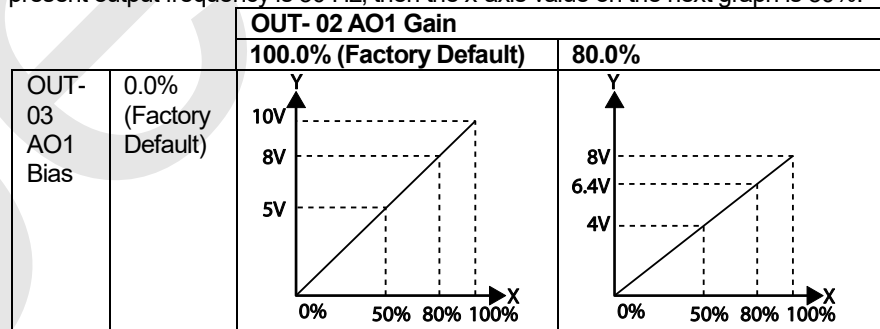

| Code               | Description  |       |  |  |
|--------------------|--|-------|--|--|
|                    | <table border="1"> <tr> <td>20.0%</td> <td> </td> <td> </td> </tr> </table>  | 20.0% |  |  |
| 20.0%              |  |       |  |  |
| OUT-04 AO1 Filter  | Sets the filter time constant of the analog output.  |       |  |  |
| OUT-04 AO1 Const % | Sets the analog output items to Constant (AO1 Mode: 15), and then the analog voltage is output at the value of the parameters set. |       |  |  |
| OUT-06 AO1 Monitor | Monitors the analog output value, which is represented as a percentage based on the 10 V maximum output voltage.                   |       |  |  |

### 9.3.2 Current Output (4–20 mA)

Select the items to be output from AO2 (Analog Output 2) terminal of the inverter terminal block and adjust the output sizes.

| Group | Code | LCD Display | Parameter Setting |           | Unit |
|-------|------|-------------|-------------------|-----------|------|
| OUT   | 07   | AO2 Mode    | 0                 | Frequency | -    |
|       | 08   | AO2 Gain    | -                 | 80.0      | %    |
|       | 09   | AO2 Bias    | -                 | 20.0      | %    |
|       | 10   | AO2 Filter  | -                 | 5         | ms   |
|       | 11   | AO2 Const % | -                 | 0.0       | %    |
|       | 12   | AO2 Monitor | -                 | 0.0       | %    |

#### Current Output Setting Details

| Code            | Description              |   |
|-----------------|--------------------------|---|
| OUT-07 AO2 Mode | Select the output types. |   |
|                 | Setting                  | Description   |
|                 | 0                        | Frequency   |
| 1               | Output Current           | A 10 V output is supplied from 200% of the inverter-rated current (based on CT: Constant Torque). |

| Code | Description    |  |
|------|----------------|--|
| 2    | Output Voltage | Sets the outputs based on the inverter output voltage. A 10 V output is supplied from the voltage set at BAS-15 (Rated V). If 0 V is set at BAS-15, 200 V/400 V models output 10 V based on the actual input voltage (220 V and 440 V respectively). |
| 3    | DC Link Volt   | Outputs the inverter DC link voltage as the standard. Outputs 10 V when the DC link voltage is 410 VDC for 200 V models, and 820 VDC for 400 V models.   |
| 4    | Torque         | Outputs the generated torque as the standard. Outputs 10 V at 250% of the motor-rated torque.  |
| 5    | Output Power   | Monitors the output wattage. 200% of the rated output is the maximum display voltage (10 V).   |
| 6    | Idse           | Outputs the maximum voltage at 200% of the no load current.  |
| 7    | Iqse           | Outputs the maximum voltage at 250% of the rated torque current.<br>Rated torque current = $\sqrt{\text{rated current}^2 - \text{Non-load current}^2}$   |
| 8    | Target Freq    | Outputs the set frequency as the standard. Outputs 10 V at the maximum frequency (DRV-20).   |
| 9    | Ramp Freq      | Outputs frequency calculated with Acc/Dec function as a standard. This may vary depending on the actual output frequency. Outputs 10 V.  |
| 10   | Speed Fdb      | Displays the speed information of the input into the encoder extension module. It produces 10 V at the maximum frequency (DRV-20).   |
| 11   | Speed Dev      | Outputs the difference between the speed reference (command) and the motor's rotation speed that inputs into the encoder extension module. It outputs 10 V at twice the rated slip frequency. It is valid only in Vector Control mode.               |
| 12   | PID Ref Value  | Outputs command value of a PID controller as the standard. Outputs approximately 6.6 V at 100%.  |
| 13   | PID Fdb Value  | Outputs feedback volume of a PID controller as the standard. Outputs approximately 6.6 V at 100%.  |
| 14   | PID Output     | Outputs the output value of a PID controller as the standard. Outputs approximately 10 V at 100%.  |
| 15   | Constant       | Outputs the OUT-05 (AO1 Const %) value as a standard.  |

Adjusts output value and offset. If frequency is selected as an output item, it will operate as shown below.

$$AO2 = \frac{\text{Frequency}}{\text{MaxFreq}} \times AO2Gain + AO2Bias$$

OUT-08 AO2 Gain,  
OUT-09 AO2 Bias

The graph below illustrates how the analog current output (AO2) changes depending on OUT-02 (AO2 Gain) and OUT-3 (AO2 Bias) values. The Y-axis is the analog output current (0–20 mA), and the X-axis is a percentage of the output. Example, if the maximum frequency set at DRV-20 (Max Freq) is 60 Hz and the present output frequency is 30 Hz, then the x-axis value on the next graph is 50%.

| OUT- 08 AO2 Gain |                         |
|------------------|-------------------------|
| 100.0%           | 80.0% (Factory Default) |

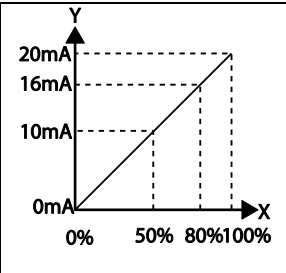
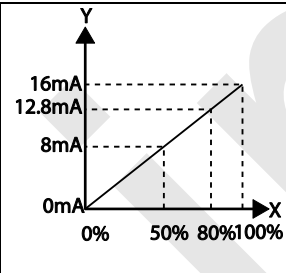
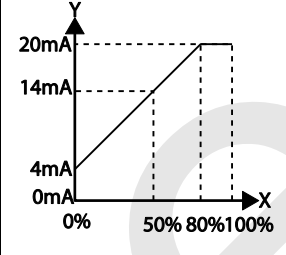
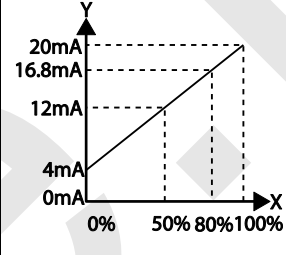
| Code               | Description  |                         |  |
|--------------------|--|-------------------------|--|
|                    | OUT-09 AO2 Bias  | 0.0%                    |   |
|                    |  | 20.0% (factory Default) |   |
| OUT-10 AO2 Filter  | Sets the filter time constant of the analog output.  |                         |  |
| OUT-11 AO2 Const % | Sets the analog output items to Constant (AO2 Mode: 15), and then the analog current is output at the value of the parameters set. |                         |  |
| OUT-12 AO2 Monitor | Monitors the analog output value, which is represented as a percentage based on the 20 mA maximum output voltage.                  |                         |  |

**Note**

When 4–20 mA is used as the output, tune OUT-08 AO2 Gain and OUT-09 AO2 Bias as follows.

- 1 Set OUT-07 AO2 Mode to Constant and OUT11 AO2 Const % to 0.0%.
- 2 After setting OUT-09 AO2 Bias to 20.0%, ensure that that the current is 4 mA. If the current is lower than 4 mA, gradually increase OUT-09 AO2 Bias until it measures 4 mA. If the current is higher than 4 mA, gradually decrease OUT-09 AO2 Bias until it measures 4 mA.
- 3 Set OUT11 AO2 Const % to 100.0%. After setting OUT-08 AO2 Gain to 80.0%, ensure that the current is 20 mA. If the current is lower than 20 mA, gradually increase OUT-08 AO2 Gain until it measures 20 mA. If the current is higher than 20 mA, gradually decrease OUT-08 AO2 Gain until it measures 20 mA.
- 4 When 0-20 mA is used as the output, set OUT-08 AO2 Gain to 100% and OUT-09 AO2 Bias to 0.0%.
- 5 The functions for each code are the same as the item of 0–10 V output. And, the output range is 0–20 mA.



### 9.3.3 Voltage Output (-10~+10V) Using an I/O Expansion Module

If the optional I/O expansion module is installed, the operating status can be monitored using the bipolar voltage output of the I/O expansion module.

| Group | Code | LCD Display | Parameter Setting |           | Unit |
|-------|------|-------------|-------------------|-----------|------|
| OUT   | 14   | AO3 Mode    | 0                 | Frequency | -    |
|       | 15   | AO3 Gain    | -                 | 100.0     | %    |
|       | 16   | AO3 Bias    | -                 | 0.0       | %    |
|       | 17   | AO3 Filter  | -                 | 5         | Msec |
|       | 18   | AO3 Const % | -                 | 0.0       | %    |
|       | 19   | AO3 Monitor | -                 | 0.0       | %    |

#### Voltage Output (-10~+10 V) Details

| Code                             | Description   |                   |                   |                          |       |                           |              |              |               |                   |                   |                |                                |           |         |   |
|----------------------------------|---|-------------------|-------------------|--------------------------|-------|---------------------------|--------------|--------------|---------------|-------------------|-------------------|----------------|--------------------------------|-----------|---------|---|
| OUT-14 AO3 Mode                  | The output mode can be set identically to when the AO1 voltage output is used. However, because bipolar voltage output is possible for AO3, unipolar (0~+10V) or bipolar (-10~+10V) voltage can be produced according to the type of the output variable.<br><br>Examples of bipolar output voltages are as follows.  |                   |                   |                          |       |                           |              |              |               |                   |                   |                |                                |           |         |   |
|                                  | <table border="1"> <thead> <tr> <th>Output Direction</th> <th colspan="3">Related Functions</th> </tr> </thead> <tbody> <tr> <td rowspan="2">Forward(+)<br/>/Reverse(-)</td> <td>0: Frequency</td> <td>9: Ramp Freq</td> <td>10: Speed Fdb</td> </tr> <tr> <td>12: PID Ref Value</td> <td>13: PID Fdb Value</td> <td>14: PID Output</td> </tr> <tr> <td>Reverse(-)<br/>/Regenerative(-)</td> <td>4: Torque</td> <td>7: Iqss</td> <td>-</td> </tr> </tbody> </table> | Output Direction  | Related Functions |                          |       | Forward(+)<br>/Reverse(-) | 0: Frequency | 9: Ramp Freq | 10: Speed Fdb | 12: PID Ref Value | 13: PID Fdb Value | 14: PID Output | Reverse(-)<br>/Regenerative(-) | 4: Torque | 7: Iqss | - |
|                                  | Output Direction  | Related Functions |                   |                          |       |                           |              |              |               |                   |                   |                |                                |           |         |   |
|                                  | Forward(+)<br>/Reverse(-)   | 0: Frequency      | 9: Ramp Freq      | 10: Speed Fdb            |       |                           |              |              |               |                   |                   |                |                                |           |         |   |
| 12: PID Ref Value                |   | 13: PID Fdb Value | 14: PID Output    |                          |       |                           |              |              |               |                   |                   |                |                                |           |         |   |
| Reverse(-)<br>/Regenerative(-)   | 4: Torque   | 7: Iqss           | -                 |                          |       |                           |              |              |               |                   |                   |                |                                |           |         |   |
|                                  |   |                   |                   |                          |       |                           |              |              |               |                   |                   |                |                                |           |         |   |
|                                  |   |                   |                   |                          |       |                           |              |              |               |                   |                   |                |                                |           |         |   |
| OUT-15 AO3 Gain, OUT-16 AO3 Bias | The graph below illustrates how the analog voltage output (AO3) changes depending on the OUT-15 (AO3 Gain) and OUT-16 (AO3 Bias) values.<br><br>The Y-axis is analog output voltage (-10~+10V), and the X-axis is a percentage of the output. For example, if the maximum frequency set at DRV-20 (Max Freq) is 60 Hz and the present output frequency is 30 Hz, then the x-axis value on the next graph is 50%.  |                   |                   |                          |       |                           |              |              |               |                   |                   |                |                                |           |         |   |
|                                  | <table border="1"> <thead> <tr> <th colspan="2">OUT- 08 AO3 Gain</th> </tr> </thead> <tbody> <tr> <td>100.0% (Factory Default)</td> <td>80.0%</td> </tr> </tbody> </table>  | OUT- 08 AO3 Gain  |                   | 100.0% (Factory Default) | 80.0% |                           |              |              |               |                   |                   |                |                                |           |         |   |
|                                  | OUT- 08 AO3 Gain  |                   |                   |                          |       |                           |              |              |               |                   |                   |                |                                |           |         |   |
| 100.0% (Factory Default)         | 80.0%   |                   |                   |                          |       |                           |              |              |               |                   |                   |                |                                |           |         |   |
|                                  |   |                   |                   |                          |       |                           |              |              |               |                   |                   |                |                                |           |         |   |

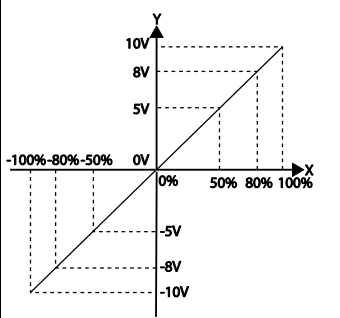
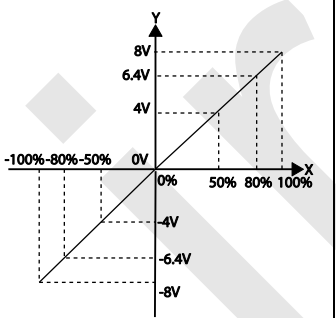
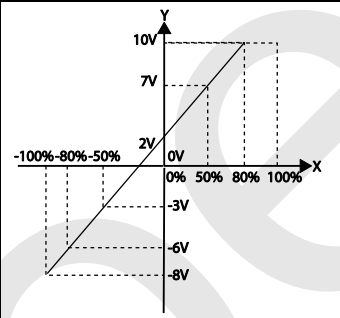
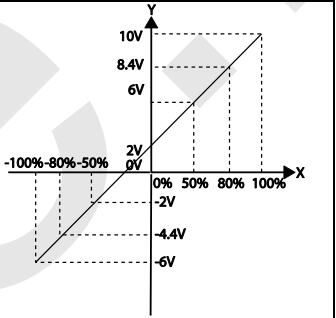
| Code | Description        |                              |  |   |
|------|--------------------|------------------------------|--|---|
|      | OUT-16<br>AO3 Bias | 0.0%<br>(factory<br>Default) |   |   |
|      |                    | 20.0%                        |  |  |

### 9.3.4 Current Output (4–20 mA/0–20 mA) Using an I/O Expansion Module



If the optional I/O expansion module is installed, the current output (0–20 mA or 4–20 mA) can be produced via terminal AO4. The setting details are identical to those of AO1 analog output terminal.

| Group | Code | LCD Display | Parameter Setting |           | Unit |
|-------|------|-------------|-------------------|-----------|------|
| OUT   | 20   | AO4 Mode    | 0                 | Frequency | -    |
|       | 21   | AO4 Gain    | -                 | 100.0     | %    |
|       | 22   | AO4 Bias    | -                 | 0.0       | %    |
|       | 23   | AO4 Filter  | -                 | 5         | ms   |
|       | 24   | AO4 Const % | -                 | 0.0       | %    |
|       | 25   | AO4 Monitor | -                 | 0.0       | %    |

## 9.4 Relay Output and Multi-function Output Terminal Settings

| Group | Code  | LCD Display   | Parameter Setting |       | Unit |
|-------|-------|---------------|-------------------|-------|------|
| OUT   | 30    | Trip Out Mode | -                 | 010   | bit  |
|       | 31    | Relay 1       | 28                | Trip  | -    |
|       | 32    | Relay 2       | 14                | Run   | -    |
|       | 33    | Q1 Define     | 1                 | FDT-1 |      |
|       | 34–36 | Relay 3–5     | -                 | -     | -    |
|       | 41    | DO Status     | -                 | -     | bit  |

### Relay Output and Multi-function Output Terminal Setting Details

| Code   | Description  |       |  |   |      |
|--|--|-------|--|---|------|
| OUT-30 Trip Out Mode   | Set OUT-30 (Trip Out Mode) to enable or disable the fault relay.                   |       |  |   |      |
|  | Bit on   |       | Bit off  |   |      |
|  |  |       |  |   |      |
|  | <b>Setting option</b>  |       | <b>Function</b>  |   |      |
|  | Bit3   | Bit2  | Bit1   | The top-right corner of the display is 'Bit 1'.   |      |
|  |  |       | ✓  | Operates when a low voltage fault trip occurs.  |      |
|  | ✓  |       | Operates when a fault trip other than low voltage occurs.                          |   |      |
| ✓  |  |       | Operates when auto restart fails (PRT-08–09).                                      |   |      |
| OUT-31 Relay1, OUT-32, Relay2, OUT-33 Q1 Define, OUT-34–36 Relay 3–5 | Set output options for the relays and multi-function output terminal Q1.           |       |  |   |      |
|  | <b>Setting</b>   |       | <b>Function</b>  |   |      |
|  | 0  | None  |  | No output signal  |      |
|  | 1  | FDT-1 |  | Inspects whether the output frequency for the inverter reaches the frequency set by the user. The inverter begins to operate when the condition is met:<br><b>Absolute value</b> (set frequency - output frequency) < detected frequency width/2.<br>When the detected frequency width is 10 Hz, the FDT-1 output is as shown in the graph below. |      |
|  | Group  | Code  | LCD Display  | Parameter setting   | Unit |
|  | OUT  | 58    | FDT Band (Hz)  | -   10.00   | Hz   |

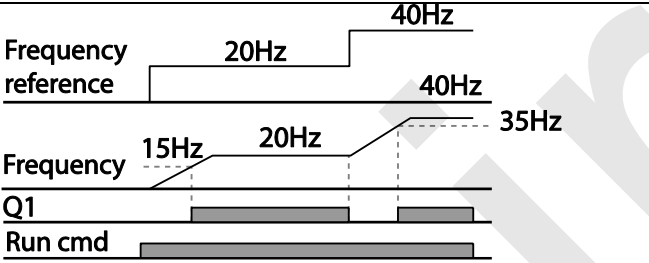
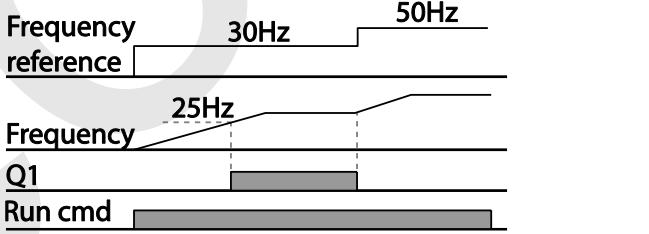
| Code  | Description |   |                   |       |             |                   |  |      |     |    |               |   |       |    |    |               |   |       |    |
|-------|-------------|---|-------------------|-------|-------------|-------------------|--|------|-----|----|---------------|---|-------|----|----|---------------|---|-------|----|
|       |             |   |                   |       |             |                   |  |      |     |    |               |   |       |    |    |               |   |       |    |
| 2     | FDT-2       | <p>Outputs a signal when the set frequency and detected frequency (FDT frequency) are equal, and fulfills the FDT-1 condition at the same time:<br/> <b>[Absolute value (set frequency – detected frequency) &lt; detected frequency width / 2 ] &amp; [ FDT-1 ] condition is met</b></p> <p>The detected frequency width is 10 Hz. When the detected frequency is set to 30 Hz, the FDT-2 output is as shown in the graph below.</p> <table border="1" data-bbox="559 875 1208 1029"> <thead> <tr> <th>Group</th> <th>Code</th> <th>LCD Display</th> <th colspan="2">Parameter setting</th> <th>Unit</th> </tr> </thead> <tbody> <tr> <td rowspan="2">OUT</td> <td>57</td> <td>FDT Frequency</td> <td>-</td> <td>30.00</td> <td>Hz</td> </tr> <tr> <td>58</td> <td>FDT Band (Hz)</td> <td>-</td> <td>10.00</td> <td>Hz</td> </tr> </tbody> </table>  | Group             | Code  | LCD Display | Parameter setting |  | Unit | OUT | 57 | FDT Frequency | - | 30.00 | Hz | 58 | FDT Band (Hz) | - | 10.00 | Hz |
| Group | Code        | LCD Display   | Parameter setting |       | Unit        |                   |  |      |     |    |               |   |       |    |    |               |   |       |    |
| OUT   | 57          | FDT Frequency   | -                 | 30.00 | Hz          |                   |  |      |     |    |               |   |       |    |    |               |   |       |    |
|       | 58          | FDT Band (Hz)   | -                 | 10.00 | Hz          |                   |  |      |     |    |               |   |       |    |    |               |   |       |    |
| 3     | FDT-3       | <p>Outputs a signal when the operating frequency meets the following condition:<br/> <b>Absolute value (detected frequency – output frequency) &lt; detected frequency width / 2</b></p> <table border="1" data-bbox="559 1435 1208 1532"> <thead> <tr> <th>Group</th> <th>Code</th> <th>LCD Display</th> <th colspan="2">Initial Setting</th> <th>Unit</th> </tr> </thead> <tbody> <tr> <td rowspan="2">OUT</td> <td>57</td> <td>FDT Frequency</td> <td>-</td> <td>30.00</td> <td>Hz</td> </tr> <tr> <td>58</td> <td>FDT Band (Hz)</td> <td>-</td> <td>10.00</td> <td>Hz</td> </tr> </tbody> </table>  | Group             | Code  | LCD Display | Initial Setting   |  | Unit | OUT | 57 | FDT Frequency | - | 30.00 | Hz | 58 | FDT Band (Hz) | - | 10.00 | Hz |
| Group | Code        | LCD Display   | Initial Setting   |       | Unit        |                   |  |      |     |    |               |   |       |    |    |               |   |       |    |
| OUT   | 57          | FDT Frequency   | -                 | 30.00 | Hz          |                   |  |      |     |    |               |   |       |    |    |               |   |       |    |
|       | 58          | FDT Band (Hz)   | -                 | 10.00 | Hz          |                   |  |      |     |    |               |   |       |    |    |               |   |       |    |

| Code  | Description  |   |                   |      |             |                   |      |     |    |               |         |    |    |               |         |    |
|-------|--------------|---|-------------------|------|-------------|-------------------|------|-----|----|---------------|---------|----|----|---------------|---------|----|
|       |              |   |                   |      |             |                   |      |     |    |               |         |    |    |               |         |    |
| 4     | FDT-4        | <p>The output signal can be separately set for acceleration and deceleration conditions.</p> <ul style="list-style-type: none"> <li><b>In acceleration:</b> Operation frequency <math>\geq</math> Detected frequency</li> <li><b>In deceleration:</b> Operation frequency <math>&gt;</math> (Detected frequency - Detected frequency width/2)</li> </ul> <p>Detected frequency width is 10 Hz. When the detected frequency is set to 30 Hz, FDT-4 output is as shown in the graph below.</p> <table border="1"> <thead> <tr> <th>Group</th> <th>Code</th> <th>LCD Display</th> <th>Parameter setting</th> <th>Unit</th> </tr> </thead> <tbody> <tr> <td rowspan="2">OUT</td> <td>57</td> <td>FDT Frequency</td> <td>- 30.00</td> <td>Hz</td> </tr> <tr> <td>58</td> <td>FDT Band (Hz)</td> <td>- 10.00</td> <td>Hz</td> </tr> </tbody> </table> | Group             | Code | LCD Display | Parameter setting | Unit | OUT | 57 | FDT Frequency | - 30.00 | Hz | 58 | FDT Band (Hz) | - 10.00 | Hz |
| Group | Code         | LCD Display   | Parameter setting | Unit |             |                   |      |     |    |               |         |    |    |               |         |    |
| OUT   | 57           | FDT Frequency   | - 30.00           | Hz   |             |                   |      |     |    |               |         |    |    |               |         |    |
|       | 58           | FDT Band (Hz)   | - 10.00           | Hz   |             |                   |      |     |    |               |         |    |    |               |         |    |
| 5     | Over Load    | Outputs a signal at motor overload.   |                   |      |             |                   |      |     |    |               |         |    |    |               |         |    |
| 6     | IOL          | Outputs a signal when the inverter input current exceeds the rated current and a protective function is activated to prevent damage to the inverter, based on inverse proportional characteristics.   |                   |      |             |                   |      |     |    |               |         |    |    |               |         |    |
| 7     | Under Load   | Outputs a signal at load fault warning.   |                   |      |             |                   |      |     |    |               |         |    |    |               |         |    |
| 8     | Fan Warning  | Outputs a signal at fan fault warning.  |                   |      |             |                   |      |     |    |               |         |    |    |               |         |    |
| 9     | Stall        | Outputs a signal when a motor is overloaded and stalled.  |                   |      |             |                   |      |     |    |               |         |    |    |               |         |    |
| 10    | Over Voltage | Outputs a signal when the inverter DC link voltage rises above the protective operation voltage.  |                   |      |             |                   |      |     |    |               |         |    |    |               |         |    |
| 11    | Low Voltage  | Outputs a signal when the inverter DC link voltage drops below the low voltage protective level.  |                   |      |             |                   |      |     |    |               |         |    |    |               |         |    |
| 12    | Over Heat    | Outputs signal when the inverter overheats.   |                   |      |             |                   |      |     |    |               |         |    |    |               |         |    |
| 13    | Lost Command | Outputs a signal when there is a loss of analog input terminal and RS-485 communication command at the terminal block. Outputs a signal when communication power is present and an I/O expansion module is installed. It also outputs a signal  |                   |      |             |                   |      |     |    |               |         |    |    |               |         |    |

| Code  |               | Description  |                   |               |             |                   |      |     |       |           |    |          |   |     |    |         |    |               |   |    |           |    |           |   |
|-------|---------------|--|-------------------|---------------|-------------|-------------------|------|-----|-------|-----------|----|----------|---|-----|----|---------|----|---------------|---|----|-----------|----|-----------|---|
|       |               | when losing analog input and communication power commands.   |                   |               |             |                   |      |     |       |           |    |          |   |     |    |         |    |               |   |    |           |    |           |   |
| 14    | RUN           | <p>Outputs a signal when an operation command is entered and the inverter outputs voltage.<br/>No signal output during DC braking.</p> <p><b>Frequency</b></p> <p><b>Q1</b></p> <p><b>Run cmd</b></p>  |                   |               |             |                   |      |     |       |           |    |          |   |     |    |         |    |               |   |    |           |    |           |   |
| 15    | Stop          | Outputs a signal at operation command off, and when there is no inverter output voltage.   |                   |               |             |                   |      |     |       |           |    |          |   |     |    |         |    |               |   |    |           |    |           |   |
| 16    | Steady        | Outputs a signal in steady operation.  |                   |               |             |                   |      |     |       |           |    |          |   |     |    |         |    |               |   |    |           |    |           |   |
| 17    | Inverter Line | Outputs a signal while the motor is driven by the inverter line.   |                   |               |             |                   |      |     |       |           |    |          |   |     |    |         |    |               |   |    |           |    |           |   |
| 18    | Comm Line     | <p>Outputs a signal when multi-function input terminal (switching) is entered.</p> <table border="1"> <thead> <tr> <th>Group</th> <th>Code</th> <th>LCD Display</th> <th>Initial Setting</th> <th>Unit</th> </tr> </thead> <tbody> <tr> <td>IN</td> <td>65-72</td> <td>Px Define</td> <td>16</td> <td>Exchange</td> <td>-</td> </tr> <tr> <td rowspan="2">OUT</td> <td>32</td> <td>Relay 2</td> <td>15</td> <td>Inverter Line</td> <td>-</td> </tr> <tr> <td>33</td> <td>Q1 Define</td> <td>16</td> <td>Comm Line</td> <td>-</td> </tr> </tbody> </table> <p>For details, refer to <a href="#">8.23 Supply Power Transition</a> on page <a href="#">253</a>.</p> | Group             | Code          | LCD Display | Initial Setting   | Unit | IN  | 65-72 | Px Define | 16 | Exchange | - | OUT | 32 | Relay 2 | 15 | Inverter Line | - | 33 | Q1 Define | 16 | Comm Line | - |
| Group | Code          | LCD Display  | Initial Setting   | Unit          |             |                   |      |     |       |           |    |          |   |     |    |         |    |               |   |    |           |    |           |   |
| IN    | 65-72         | Px Define  | 16                | Exchange      | -           |                   |      |     |       |           |    |          |   |     |    |         |    |               |   |    |           |    |           |   |
| OUT   | 32            | Relay 2  | 15                | Inverter Line | -           |                   |      |     |       |           |    |          |   |     |    |         |    |               |   |    |           |    |           |   |
|       | 33            | Q1 Define  | 16                | Comm Line     | -           |                   |      |     |       |           |    |          |   |     |    |         |    |               |   |    |           |    |           |   |
| 19    | Speed Search  | Outputs a signal during inverter speed search operation.<br>For details, refer to <a href="#">8.19 Speed Search Operation</a> on page <a href="#">244</a> .  |                   |               |             |                   |      |     |       |           |    |          |   |     |    |         |    |               |   |    |           |    |           |   |
| 20    | Step Pulse    | Outputs a signal when a step is completed in an auto sequence operation.   |                   |               |             |                   |      |     |       |           |    |          |   |     |    |         |    |               |   |    |           |    |           |   |
| 21    | Seq Pulse     | Outputs a signal when a sequence is completed in an auto sequence operation.   |                   |               |             |                   |      |     |       |           |    |          |   |     |    |         |    |               |   |    |           |    |           |   |
| 22    | Ready         | Outputs a signal when the inverter is in standby mode and ready to receive external operation commands.  |                   |               |             |                   |      |     |       |           |    |          |   |     |    |         |    |               |   |    |           |    |           |   |
| 23    | Trv ACC       | <p>Outputs a signal when the inverter reaches the accelerating frequency during a traverse operation.</p> <table border="1"> <thead> <tr> <th>Group</th> <th>Code</th> <th>LCD Display</th> <th>Parameter setting</th> <th>Unit</th> </tr> </thead> <tbody> <tr> <td>APP</td> <td>01</td> <td>App Mode</td> <td>1</td> <td>Traverse</td> <td>-</td> </tr> </tbody> </table>  | Group             | Code          | LCD Display | Parameter setting | Unit | APP | 01    | App Mode  | 1  | Traverse | - |     |    |         |    |               |   |    |           |    |           |   |
| Group | Code          | LCD Display  | Parameter setting | Unit          |             |                   |      |     |       |           |    |          |   |     |    |         |    |               |   |    |           |    |           |   |
| APP   | 01            | App Mode   | 1                 | Traverse      | -           |                   |      |     |       |           |    |          |   |     |    |         |    |               |   |    |           |    |           |   |
| 24    | Trv DEC       | <p>Outputs a signal when the inverter reaches the decelerating frequency during a traverse operation.</p> <table border="1"> <thead> <tr> <th>Group</th> <th>Code</th> <th>LCD Display</th> <th>Parameter setting</th> <th>Unit</th> </tr> </thead> <tbody> <tr> <td>APP</td> <td>01</td> <td>App Mode</td> <td>1</td> <td>Traverse</td> <td>-</td> </tr> </tbody> </table>  | Group             | Code          | LCD Display | Parameter setting | Unit | APP | 01    | App Mode  | 1  | Traverse | - |     |    |         |    |               |   |    |           |    |           |   |
| Group | Code          | LCD Display  | Parameter setting | Unit          |             |                   |      |     |       |           |    |          |   |     |    |         |    |               |   |    |           |    |           |   |
| APP   | 01            | App Mode   | 1                 | Traverse      | -           |                   |      |     |       |           |    |          |   |     |    |         |    |               |   |    |           |    |           |   |

| Code  |             | Description  |   |      |             |                   |      |     |           |              |   |   |     |    |                |           |     |    |                 |               |          |    |
|-------|-------------|--|---|------|-------------|-------------------|------|-----|-----------|--------------|---|---|-----|----|----------------|-----------|-----|----|-----------------|---------------|----------|----|
| 25    | MMC         | <p>Used as a multi-motor control function. By configuring the relay output and the multi-function output to MMC and configuring the APP-01 (APP Mode) to "3 (MMC), it can conduct the necessary operations for multi-motor control function.</p> <table border="1"> <thead> <tr> <th>Group</th> <th>Code</th> <th>LCD Display</th> <th>Parameter setting</th> <th>Unit</th> </tr> </thead> <tbody> <tr> <td>APP</td> <td>01</td> <td>App Mode</td> <td>3   MMC</td> <td>-</td> </tr> </tbody> </table>   | Group   | Code | LCD Display | Parameter setting | Unit | APP | 01        | App Mode     | 3   MMC   | - |     |    |                |           |     |    |                 |               |          |    |
| Group | Code        | LCD Display  | Parameter setting                                 | Unit |             |                   |      |     |           |              |   |   |     |    |                |           |     |    |                 |               |          |    |
| APP   | 01          | App Mode   | 3   MMC   | -    |             |                   |      |     |           |              |   |   |     |    |                |           |     |    |                 |               |          |    |
| 26    | Zspd Dect   | <p>Detects if the motor's rotation speed is 0 rpm during operation and if the control mode is set as a vector.</p> <table border="1"> <thead> <tr> <th>Group</th> <th>Code</th> <th>LCD Display</th> <th>Parameter setting</th> <th>Unit</th> </tr> </thead> <tbody> <tr> <td>DRV</td> <td>09</td> <td>Control Mode</td> <td>4   Vector</td> <td>-</td> </tr> <tr> <td>CON</td> <td>82</td> <td>ZSD Frequency</td> <td>-   2.00</td> <td>Hz</td> </tr> <tr> <td></td> <td>83</td> <td>ZSD Band (Hz)</td> <td>-   1.00</td> <td>Hz</td> </tr> </tbody> </table> <p>As the relay operation is dependent on the motor number (encoder signal), a fault may occur when turning the inverter on or off due to the encoder signal noise or filter time constant.</p> | Group   | Code | LCD Display | Parameter setting | Unit | DRV | 09        | Control Mode | 4   Vector  | - | CON | 82 | ZSD Frequency  | -   2.00  | Hz  |    | 83              | ZSD Band (Hz) | -   1.00 | Hz |
| Group | Code        | LCD Display  | Parameter setting                                 | Unit |             |                   |      |     |           |              |   |   |     |    |                |           |     |    |                 |               |          |    |
| DRV   | 09          | Control Mode   | 4   Vector  | -    |             |                   |      |     |           |              |   |   |     |    |                |           |     |    |                 |               |          |    |
| CON   | 82          | ZSD Frequency  | -   2.00  | Hz   |             |                   |      |     |           |              |   |   |     |    |                |           |     |    |                 |               |          |    |
|       | 83          | ZSD Band (Hz)  | -   1.00  | Hz   |             |                   |      |     |           |              |   |   |     |    |                |           |     |    |                 |               |          |    |
| 27    | Torque Dect | <p>Outputs a signal if the torque, with the control mode set as sensorless or vector, is below the following levels.</p> <table border="1"> <thead> <tr> <th>Group</th> <th>Code</th> <th>LCD Display</th> <th>Parameter setting</th> <th>Unit</th> </tr> </thead> <tbody> <tr> <td>DRV</td> <td>09</td> <td>Control Mode</td> <td>3-   Sensorless-1,<br/>4   Sensorless-2,<br/>Vector</td> <td>-</td> </tr> <tr> <td rowspan="2">OUT</td> <td>59</td> <td>TD Level</td> <td>-   100.0</td> <td>%</td> </tr> <tr> <td>60</td> <td>TD Band</td> <td>-   5.0</td> <td>%</td> </tr> </tbody> </table>   | Group   | Code | LCD Display | Parameter setting | Unit | DRV | 09        | Control Mode | 3-   Sensorless-1,<br>4   Sensorless-2,<br>Vector | - | OUT | 59 | TD Level       | -   100.0 | %   | 60 | TD Band         | -   5.0       | %        |    |
| Group | Code        | LCD Display  | Parameter setting                                 | Unit |             |                   |      |     |           |              |   |   |     |    |                |           |     |    |                 |               |          |    |
| DRV   | 09          | Control Mode   | 3-   Sensorless-1,<br>4   Sensorless-2,<br>Vector | -    |             |                   |      |     |           |              |   |   |     |    |                |           |     |    |                 |               |          |    |
| OUT   | 59          | TD Level   | -   100.0   | %    |             |                   |      |     |           |              |   |   |     |    |                |           |     |    |                 |               |          |    |
|       | 60          | TD Band  | -   5.0   | %    |             |                   |      |     |           |              |   |   |     |    |                |           |     |    |                 |               |          |    |
| 28    | Timer Out   | <p>A timer function to operate terminal output after a certain time by using multi-function terminal block input.</p> <table border="1"> <thead> <tr> <th>Group</th> <th>Code</th> <th>LCD Display</th> <th>Parameter setting</th> <th>Unit</th> </tr> </thead> <tbody> <tr> <td>IN</td> <td>65-<br/>72</td> <td>Px Define</td> <td>38   Timer In</td> <td>-</td> </tr> <tr> <td rowspan="2">OUT</td> <td>55</td> <td>Timer On Delay</td> <td>-   0.00</td> <td>Sec</td> </tr> <tr> <td>56</td> <td>Timer Off Delay</td> <td>-   0.00</td> <td>Sec</td> </tr> </tbody> </table>  | Group   | Code | LCD Display | Parameter setting | Unit | IN  | 65-<br>72 | Px Define    | 38   Timer In                                     | - | OUT | 55 | Timer On Delay | -   0.00  | Sec | 56 | Timer Off Delay | -   0.00      | Sec      |    |
| Group | Code        | LCD Display  | Parameter setting                                 | Unit |             |                   |      |     |           |              |   |   |     |    |                |           |     |    |                 |               |          |    |
| IN    | 65-<br>72   | Px Define  | 38   Timer In                                     | -    |             |                   |      |     |           |              |   |   |     |    |                |           |     |    |                 |               |          |    |
| OUT   | 55          | Timer On Delay   | -   0.00  | Sec  |             |                   |      |     |           |              |   |   |     |    |                |           |     |    |                 |               |          |    |
|       | 56          | Timer Off Delay  | -   0.00  | Sec  |             |                   |      |     |           |              |   |   |     |    |                |           |     |    |                 |               |          |    |
| 32    | ENC Tune    | Outputs a warning signal by releasing the contact point output   |   |      |             |                   |      |     |           |              |   |   |     |    |                |           |     |    |                 |               |          |    |

| Code            | Description  |  |
|-----------------|--|--|
|                 |  | if autotuning is performed, if there is no encoder board, or if APO-01 Enc Opt mode is not set to "Feedback".  |
| 33              | ENC Dir  | Outputs a warning signal when the motor rotation direction by the encoder is not set properly. The warning signal is generated when then encoder wiring is not made properly even if the encoder module has been installed and APO-01 Enc Opt Mode is set to "Feedback". |
| 36              | KEB Operating  | Outputs a signal when the energy buffering operation is performed (when an input power outage occurs and the DC power supply voltage of the inverter is low).  |
| 37              | Fire Mode  | Outputs a signal when Fire mode is in operation only if ADV-80 is set to Fire mode.  |
| 38              | Run2   | It operates when the operation command is input or the inverter is outputting voltage. Unlike "14: Run", it operates even during DC braking  |
| OUT-41 DO State | Used to check On/Off state of the DO (digital output) by each bit. |  |



## 9.5 Fault trip output using multi-function output terminals and relays

The inverter can output a fault trip state using the multi-function output terminal (Q1) and relay (Relay1).

| Group | Code | LCD Display      | Parameter Setting |       | Unit |
|-------|------|------------------|-------------------|-------|------|
| OUT   | 30   | Trip Out Mode    | -                 | 010   |      |
|       | 31   | Relay 1          | 29                | Trip  | -    |
|       | 32   | Relay 2          | 14                | Run   | -    |
|       | 33   | Q1 Define        | 1                 | FDT-1 | -    |
|       | 53   | Trip Out On Dly  | -                 | 0.00  | Sec  |
|       | 54   | Trip Out Off Dly | -                 | 0.00  | Sec  |

\* The inverter can output a fault trip status using expansion digital output terminals (OUT 34–36) if the optional I/O expansion module is installed.

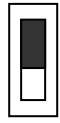
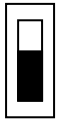
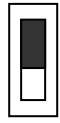
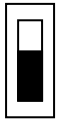
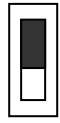
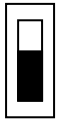
| Code   | Description  |  |   |  |  |      |      |   |  |  |   |  |  |   |  |   |   |  |  |   |
|--|--|--|---|--|--|------|------|---|--|--|---|--|--|---|--|---|---|--|--|---|
| <b>OUT-30 Trip Out Mode</b>  | Set OUT-30 (Trip Out Mode) to enable or disable the fault relay.   |  |   |  |  |      |      |   |  |  |   |  |  |   |  |   |   |  |  |   |
|  | <table border="1"> <thead> <tr> <th>Bit on</th> <th>Bit off</th> </tr> </thead> <tbody> <tr> <td></td> <td></td> </tr> </tbody> </table> | Bit on   | Bit off   |  |  |      |      |   |  |  |   |  |  |   |  |   |   |  |  |   |
|  | Bit on   | Bit off  |   |  |  |      |      |   |  |  |   |  |  |   |  |   |   |  |  |   |
|  |    |  |   |  |  |      |      |   |  |  |   |  |  |   |  |   |   |  |  |   |
| Depending on the fault trip type, the terminal and relay operation can be configured as shown in the table below.  |  |  |   |  |  |      |      |   |  |  |   |  |  |   |  |   |   |  |  |   |
| <table border="1"> <thead> <tr> <th colspan="3">Setting option</th> <th>Function</th> </tr> </thead> <tbody> <tr> <td>Bit3</td> <td>Bit2</td> <td>Bit1</td> <td>The top-right corner of the display is 'Bit 1'.</td> </tr> <tr> <td></td> <td></td> <td>✓</td> <td>Operates when a low voltage fault trip occurs.</td> </tr> <tr> <td></td> <td>✓</td> <td></td> <td>Operates when a fault trip other than low voltage occurs.</td> </tr> <tr> <td>✓</td> <td></td> <td></td> <td>Operates when auto restart fails (PRT-08–09).</td> </tr> </tbody> </table> | Setting option   |  |   | Function   | Bit3   | Bit2 | Bit1 | The top-right corner of the display is 'Bit 1'. |  |  | ✓ | Operates when a low voltage fault trip occurs. |  | ✓ |  | Operates when a fault trip other than low voltage occurs. | ✓ |  |  | Operates when auto restart fails (PRT-08–09). |
| Setting option   |  |  | Function  |  |  |      |      |   |  |  |   |  |  |   |  |   |   |  |  |   |
| Bit3   | Bit2   | Bit1   | The top-right corner of the display is 'Bit 1'.           |  |  |      |      |   |  |  |   |  |  |   |  |   |   |  |  |   |
|  |  | ✓  | Operates when a low voltage fault trip occurs.            |  |  |      |      |   |  |  |   |  |  |   |  |   |   |  |  |   |
|  | ✓  |  | Operates when a fault trip other than low voltage occurs. |  |  |      |      |   |  |  |   |  |  |   |  |   |   |  |  |   |
| ✓  |  |  | Operates when auto restart fails (PRT-08–09).             |  |  |      |      |   |  |  |   |  |  |   |  |   |   |  |  |   |
| <b>OUT-31–33</b>   | Select the terminal and relay to use for failure output and set OUT-31–33 to “28 (Trip mode)”. When a fault trip occurs in the inverter, the relevant terminal and relay will operate.   |  |   |  |  |      |      |   |  |  |   |  |  |   |  |   |   |  |  |   |
| <b>OUT-53 Trip Out On Dly, OUT-54 Trip Out Off Dly,</b>  | If a fault trip occurs, trip relay or multi-function output operates after the time delay set in OUT-53. The terminal turns off with the input initialized after the time delay set in OUT-54.   |  |   |  |  |      |      |   |  |  |   |  |  |   |  |   |   |  |  |   |

## 9.6 Output Terminal Delay Time and Terminal Types

You can adjust the operating time of the output terminals and relays. The ON and OFF delay time can be set separately. You can choose between “form A” terminal (Normally Open) and “form B” terminal (Normally Closed).

### 9.6.1 Output Terminal Delay Time

| Group | Code | LCD Display  | Parameter Setting |      | Unit |
|-------|------|--------------|-------------------|------|------|
| OUT   | 50   | DO On Delay  | -                 | 0.00 | Sec  |
|       | 51   | DO Off Delay | -                 | 0.00 | Sec  |

#### Output Terminal Delay Time Setting Details

| Code                       | Description  |
|----------------------------|--|
| <b>OUT-50 DO On Delay</b>  | Set the delay time before the output signal is turned on.  |
| <b>OUT-51 DO Off Delay</b> | Set the delay time before the output signal is turned off. |

The delay time set at codes OUT-50 and OUT-51 apply to the multi-function output terminal (Q1) and relays (Relay 1 and 2), except when the multi-function output function is in fault trip mode.

### 9.6.2 Setting the Output Terminal Type

| Group | Code | LCD Display  | Parameter Setting |     | Unit |
|-------|------|--------------|-------------------|-----|------|
| OUT   | 52   | DO NC/NO Sel | -                 | 000 | bit  |

**Output Terminal Type Setting Details**

| Code                       | Description  |
|----------------------------|--|
| <b>OUT-52 DO NC/NO Sel</b> | <p>Select the type for the relay and multi-function output terminal. An additional three terminal type selection bits at the terminal block will be added when an optional I/O expansion module is installed.</p> <p>Set the relevant bit to “0” to operate it as a “form A” terminal (Normally Open), “1” to operated it as a “form B” terminal (Normally Closed). Relay 1 and Q1 settings start from the right bit (The top-right corner of the display is ‘Bit 1’).</p> |

**9.7 Operation Time Monitor**

| Group | Code | LCD Display    | Parameter Setting |                   | Unit |
|-------|------|----------------|-------------------|-------------------|------|
| CNF   | 70   | On-time        | -                 | 0000DAY 00hr:00mm | -    |
|       | 71   | Run-time       | -                 | 0000DAY 00hr:00mm | -    |
|       | 72   | Time Reset     | 0                 | No                | -    |
|       | 74   | Fan Time       | -                 | 0000DAY 00hr:00mm | -    |
|       | 75   | Fan Time Reset | 0                 | No                | -    |

**Output Terminal Type Setting Details**

| Code                         | Description  |
|------------------------------|--|
| <b>CNF-70 On-time</b>        | Displays the accumulated power supply time. Information is displayed in [0000DAY 00hr:00mm] format.  |
| <b>CNF-71 Run-time</b>       | Displays the accumulated time of voltage output by operation command input. Information is displayed in [0000DAY 00hr:00mm] format.  |
| <b>CNF-72 Time Reset</b>     | Setting “1 (Yes)” will delete the accumulated power supply time (On-time) and operation accumulated time (Run-time), and is displayed in 0000DAY 00hr:00mm format.         |
| <b>CNF-74 Fan time</b>       | Displays the accumulated inverter cooling fan operation time. Information will be displayed in [0000DAY 00hr:00mm] format.   |
| <b>CNF-75 Fan Time Reset</b> | Setting “1 (Yes)” will delete the accumulated cooling fan operation time (on-time) and accumulated operation time (run-time), and will display it in 0/00/00 00:00 format. |

## 9.8 Setting the Keypad Language

Select the language to be displayed on the LCD keypad. Keypads using SW Ver 1.04 and later provide a language selection. The Korean language setting supports Korean and English.

| Group | Code | LCD Display  | Initial Setting |         | Unit |
|-------|------|--------------|-----------------|---------|------|
| CNF   | 01   | Language Sel | 0               | English | -    |
|       |      |              | 1               | Russian |      |
|       |      |              | 2               | Spanish |      |
|       |      |              | 3               | Italian |      |
|       |      |              | 4               | Turkish |      |

## 10 Using Protection Features

Protection features provided by the SV-iS7 series inverter are categorized into two types: Protection from damage due to an overheating motor and Protection against inverter malfunction.

### 10.1 Motor Protection

#### 10.1.1 Electrothermal Motor Overheating Prevention (ETH)

ETH is a protective function that uses the output current of an inverter without a separate temperature sensor to predict increases in motor temperature and protect the motor, based on its heat characteristics.

| Group | Code | LCD Display   | Parameter Setting |           | Setting Range     | Unit |
|-------|------|---------------|-------------------|-----------|-------------------|------|
| PRT   | 40   | ETH Trip Sel  | 0                 | None      | None/Free-Run/Dec | -    |
|       | 41   | Motor Cooling | 0                 | Self-cool | -                 | -    |
|       | 42   | ETH 1min      | -                 | 150       | 120-200           | %    |
|       | 43   | ETH Cont      | -                 | 120       | 50-180            | %    |

#### Electronic Thermal (ETH) Prevention Function Setting Details

| Code                 | Description   |             |   |
|----------------------|---|-------------|---|
| PRT-40 ETH Trip Sel  | ETH can be selected to provide motor thermal protection. The LCD screen displays "E-Thermal." |             |   |
|                      | <b>Setting</b>  |             | <b>Function</b>   |
|                      | 0   | None        | The ETH function is not activated.  |
|                      | 1   | Free-Run    | The inverter output is blocked. The motor coasts to a halt (free-run).  |
|                      | 2   | Dec         | The inverter decelerates the motor to a stop.   |
| PRT-41 Motor Cooling | Select the drive mode of the cooling fan, attached to the motor.                              |             |   |
|                      | <b>Setting</b>  |             | <b>Function</b>   |
|                      | 0   | Self-cool   | As the cooling fan is connected to the motor axis, the cooling effect varies based on motor speed. Most universal induction motors have this design.                |
|                      | 1   | Forced-cool | Additional power is supplied to operate the cooling fan. This provides expansion operation at low speeds. Motors designed for inverters typically have this design. |

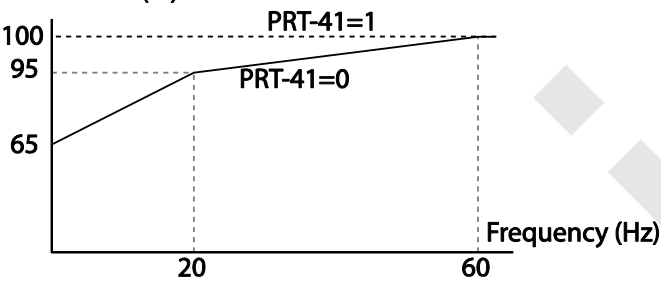
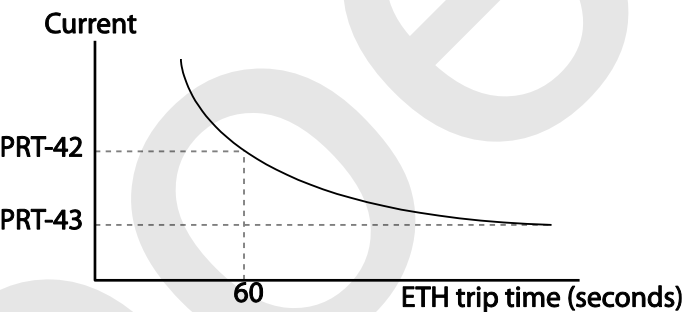
| Code             | Description   |
|------------------|---|
|                  | <p><b>Continuous rated current (%)</b></p>  <p><b>Frequency (Hz)</b></p>  |
| PRT-42 ETH 1 min | <p>The amount of input current that can be continuously supplied to the motor for 1 minute, based on the motor-rated current (BAS-13).</p>  |
| PRT-43 ETH Cont  | <p>Sets the amount of current with the ETH function activated. The range below details the set values that can be used during continuous operation without the protection function.</p>  <p><b>Current</b></p> <p><b>ETH trip time (seconds)</b></p> |

## 10.1.2 Overload Early Warning and Trip

A warning or fault trip (cutoff) occurs when the motor reaches an overload state, based on the motor-rated current. The amount of current for warnings and trips can be set separately.

| Group | Code | LCD Display    | Parameter Setting |            | Setting Range | Unit |
|-------|------|----------------|-------------------|------------|---------------|------|
| PRT   | 04   | Load Duty      | 1                 | Heavy Duty | -             | -    |
|       | 17   | OL Warn Select | 1                 | Yes        | 0-1           | -    |
|       | 18   | OL Warn Level  | -                 | 150        | 30-180        | %    |
|       | 19   | OL Warn Time   | -                 | 10.0       | 0-30          | sec  |
|       | 20   | OL Trip Select | 1                 | Free-Run   | -             | -    |
|       | 21   | OL Trip Level  | -                 | 180        | 30-200        | %    |
|       | 22   | OL Trip Time   | -                 | 60.0       | 0-60.0        | sec  |
| OUT   | 31   | Relay 1        | 5                 | Over Load  | -             | -    |
|       | 32   | Relay 2        |                   |            | -             |      |
|       | 33   | Q1 Define      |                   |            | -             |      |

### Overload Early Warning and Trip Setting Details

| Code   | Description   |          |          |   |  |   |  |
|--|---|----------|----------|---|--|---|--|
| PRT-04 Load Duty                                   | Select the load level.  |          |          |   |  |   |  |
|  | <table border="1"> <thead> <tr> <th>Setting</th> <th>Function</th> </tr> </thead> <tbody> <tr> <td>0</td> <td>Normal Duty<br/>Use this setting for light loads, such as, fans and pumps (overload tolerance: 110% of rated underload current for 1 minute).</td> </tr> <tr> <td>1</td> <td>Heavy Duty<br/>Use this setting for heavy loads, such as, cranes and parking elevators (overload tolerance: 150% of rated heavy load current for 1 minute).</td> </tr> </tbody> </table> | Setting  | Function | 0 | Normal Duty<br>Use this setting for light loads, such as, fans and pumps (overload tolerance: 110% of rated underload current for 1 minute). | 1 | Heavy Duty<br>Use this setting for heavy loads, such as, cranes and parking elevators (overload tolerance: 150% of rated heavy load current for 1 minute). |
|  | Setting   | Function |          |   |  |   |  |
| 0  | Normal Duty<br>Use this setting for light loads, such as, fans and pumps (overload tolerance: 110% of rated underload current for 1 minute).  |          |          |   |  |   |  |
| 1  | Heavy Duty<br>Use this setting for heavy loads, such as, cranes and parking elevators (overload tolerance: 150% of rated heavy load current for 1 minute).  |          |          |   |  |   |  |
|  |   |          |          |   |  |   |  |
| PRT-17<br>OL Warn Select                           | If the overload reaches the warning level, the terminal block multi-function output terminal and relay are used to output a warning signal. If "1 (Yes)" is selected, it will operate. If "0 (No)" is selected, it will not operate.  |          |          |   |  |   |  |
| PRT-18<br>OL Warn Level,<br>PRT-19<br>OL Warn Time | When the input current to the motor is greater than the overload warning level (OL Warn Level) and continues at that level during the overload warning time (OL Warn Time), the multi-function output (Relay 1, Q1) sends a warning signal. When Over Load is selected at OUT-31 and OUT-33, the multi-function output terminal or relay outputs a signal. The signal output does not block the inverter output.  |          |          |   |  |   |  |
| PRT-20<br>OL Trip Select                           | Select the inverter protective action in the event of an overload fault trip.   |          |          |   |  |   |  |
|  | <table border="1"> <thead> <tr> <th>Setting</th> <th>Function</th> </tr> </thead> <tbody> <tr> <td>0</td> <td>None<br/>No protective action is taken.</td> </tr> </tbody> </table>  | Setting  | Function | 0 | None<br>No protective action is taken.   |   |  |
|  | Setting   | Function |          |   |  |   |  |
| 0  | None<br>No protective action is taken.  |          |          |   |  |   |  |
|  |   |          |          |   |  |   |  |

| Code   | Description   |          |   |
|--|---|----------|---|
|  | 1   | Free-Run | In the event of an overload fault, inverter output is blocked and the motor will free-run due to inertia. |
|  | 3   | Dec      | If a fault trip occurs, the motor decelerates and stops.  |
| PRT-21 OL Trip Level,<br>PRT-22 OL Trip Time | When the current supplied to the motor is greater than the preset value of the overload trip level (OL Trip Level) and continues to be supplied during the overload trip time (OL Trip Time), the inverter output is either blocked according to the preset mode from PRT-17 or slows to a stop after deceleration. |          |   |

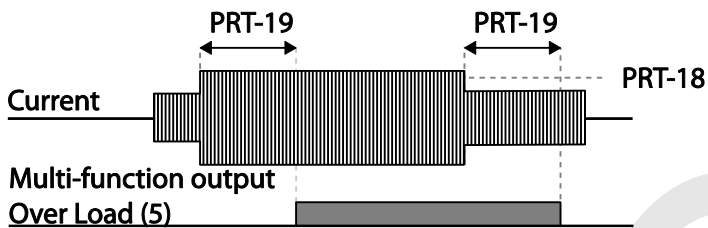

### Note

Overload warnings warn of an overload before an overload fault trip occurs. The overload warning signal may not work in an overload fault trip situation, if the overload warning level (OL Warn Level) and the overload warning time (OL Warn Time) are set higher than the overload trip level (OL Trip Level) and the overload trip time (OL Trip Time).

## 10.1.3 Stall Prevention and Flux Braking

The stall prevention function is a protective function that prevents motors from stalling due to overloads. If a motor stall occurs due to an overload, the inverter operation frequency is adjusted automatically. When a stall is caused by overload, high currents induced in the motor may cause motor overheating or damage the motor and interrupt operation of the motor-driven devices.

In this case, the motor decelerates with optimum deceleration without a braking resistor by using flux braking. If the deceleration time is too short, an over voltage fault trip may occur because of regenerative energy from the motor. The flux braking makes the motor use regenerate energy, therefore optimum deceleration is available without over voltage fault trip.



To protect the motor from overload faults, the inverter output frequency is adjusted automatically, based on the size of load.

| Group | Code  | LCD Display                  | Parameter Setting |        | Setting Range              | Unit |
|-------|-------|------------------------------|-------------------|--------|----------------------------|------|
| PRT   | 50    | Stall Prevent & Flux Braking | -                 | 0 0000 | -                          | Bit  |
|       | 51    | Stall Freq 1                 | -                 | 60.00  | Starting Freq–Stall Freq 1 | Hz   |
|       | 52    | Stall Level 1                | -                 | 180    | 30–250                     | %    |
|       | 53    | Stall Freq 2                 | -                 | 60.00  | Stall Freq 1–Stall Freq 3  | Hz   |
|       | 54    | Stall Level 2                | -                 | 180    | 30–250                     | %    |
|       | 55    | Stall Freq 3                 | -                 | 60.00  | Stall Freq 2–Stall Freq 4  | Hz   |
|       | 56    | Stall Level 3                | -                 | 180    | 30–250                     | %    |
|       | 57    | Stall Freq 4                 | -                 | 60.00  | Stall Freq 3–Max. Freq     | Hz   |
|       | 58    | Stall Level 4                | -                 | 180    | 30–250                     | %    |
| OUT   | 31–33 | Relay1,2, Q1                 | 9                 | Stall  | -                          | -    |

## Stall Prevention Function and Flux Braking Setting Details

| Code                 | Description  |       |  |       |       |   |
|----------------------|--|-------|--|-------|-------|---|
| PRT-50 Stall Prevent | Stall prevention can be configured for acceleration, deceleration, or while operating a motor at constant speed. When the LCD segment is on, the corresponding bit is off. |       |  |       |       |   |
|                      | <b>Item</b>  |       | <b>Bit Status (On)</b>   |       |       | <b>Bit Status (Off)</b>                               |
|                      | Keypad display   |       |  |       |       |   |
|                      | <b>Setting</b>   |       |  |       |       | <b>Function</b>                                       |
|                      | Bit5   | Bit 4 | Bit 3  | Bit 2 | Bit 1 |   |
|                      |  |       |  |       | ✓     | Stall protection during acceleration                  |
|                      |  |       |  | ✓     |       | Stall protection while operating at a constant speed  |
|                      |  |       | ✓  |       |       | Stall protection during deceleration                  |
|                      |  | ✓     |  |       |       | Flux braking during deceleration                      |
|                      | ✓  |       |  |       |       | Stall protection during acceleration & constant speed |
| <b>Setting</b>       |  |       | <b>Function</b>  |       |       |   |
| 0 0001               | Stall protection during acceleration   |       | If the inverter output current exceeds the preset stall level (PRT-52, 54, 56, 58) during acceleration, the motor stops accelerating and starts decelerating. If current level stays above the stall level, the motor decelerates to the start frequency (DRV-19). If the current level causes |       |       |   |

| Code        | Description  |   |
|-------------|--|---|
| 1 0001      | Stall prevention during acceleration (Mode2)                 | deceleration below the preset level while operating the stall protection function, the motor resumes acceleration.<br>If the inverter's output current exceeds the preset stall level (PRT-52, 54...) during acceleration, the inverter adjusts the output frequency to prevent stalling. The inverter performs a PI control on the current level to adjust the output frequency to be above the stall level. While the stall prevention feature is activated, the inverter starts accelerating again when the the current drops below the the set level. |
| 0 0010      | Stall protection while operating at constant speed           | Similar to stall protection function during acceleration, the output frequency automatically decelerates when the current level exceeds the preset stall level while operating at constant speed. When the load current decelerates below the preset level, it resumes acceleration.  |
| 1 0010      | Stall prevention while operating at a constant speed (Mode2) | Similar to the stall protection function during acceleration (Mode 2), if the inverter output current exceeds the preset stall level while operating at a constant speed, the inverter adjusts the output frequency according to the load current. When the load current drops below the preset level, the inverter resumes acceleration.   |
| 1 or 0 0100 | Stall protection during deceleration                         | The inverter decelerates and keeps the DC link voltage below a certain level to prevent an over voltage fault trip during deceleration. As a result, deceleration times can be longer than the set time depending on the load.  |
| 1 or 0 1000 | Flux braking during deceleration                             | When using flux braking, deceleration time may be reduced because regenerative energy is expended at the motor.   |
| 1 or 0 1100 | Stall protection and flux braking during deceleration        | Stall protection and flux braking operate together during deceleration to achieve the shortest and most stable deceleration performance.  |

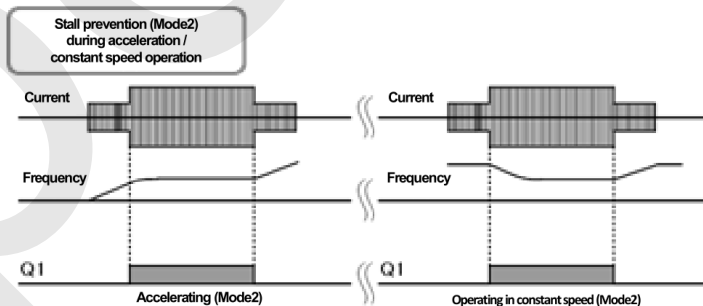

Mode2: The frequency is adjusted according to the stall level setting and load current.

| Code   | Description  |
|--|--|
|  | <div data-bbox="299 285 1015 608"> <p><b>Stall prevention (Mode1) during acceleration / constant speed operation</b></p> <p>Mode1: Decelerates to the start frequency according to the stall level setting.</p> </div> <div data-bbox="299 618 788 937"> <p><b>Stall Prevention during deceleration</b></p> <p>Decelerating</p> </div>   |
| <p>PRT-51 Stall Freq 1–<br/>PRT-58 Stall Level 4</p> | <p>Additional stall protection levels can be configured for different frequencies, based on the load type. As shown in the graph below, the stall level can be set above the base frequency. The lower and upper limits are set using numbers that correspond in ascending order. For example, the range for Stall Frequency 2 (Stall Freq 2) becomes the lower limit for Stall Frequency 1 (Stall Freq 1) and the upper limit for Stall Frequency 3 (Stall Freq 3).</p> <div data-bbox="299 1130 1173 1516"> </div> |

## Note

Stall protection and flux braking operate together only during deceleration. Turn on the third and fourth bits of PRT-50 (Stall Prevention) to achieve the shortest and most stable deceleration performance without triggering an over voltage fault trip for loads with high inertia and short deceleration times. Do not use this function when frequent deceleration of the load is required, as the motor can overheat and be easily

damaged.

### ⓘ Caution

- Use caution when decelerating while using stall protection since the deceleration time can take longer than the time set, depending on the load. Acceleration stops when stall protection operates during acceleration. This may make the actual acceleration time longer than the preset acceleration time.
- When the motor is operating, Stall Level 1 applies and determines the operation of stall protection.

## 10.1.4 Motor Overheat Sensor Input

To use the motor overheat protection, connect the overheat protection temperature sensor (PT 100, PTC) installed in the motor to the inverter's analog input terminal.

| Group | Code  | LCD Display    | Parameter Setting |            | Setting Range | Unit |
|-------|-------|----------------|-------------------|------------|---------------|------|
| PRT   | 34    | Thermal-T Sel  | 1                 | Free-Run   | -             | -    |
|       | 35    | Thermal In Src | 1                 | V1         | -             | -    |
|       | 36    | Thermal-T Lev  | -                 | 50.0       | 0–100         | %    |
|       | 37    | Thermal-T Area | 0                 | Low        | Low/High      | -    |
| OUT   | 07    | AO2 Mode       | 14                | Constant   | -             | -    |
|       | 08    | AO2 Const      | 11                | 100%       | 0–100         | %    |
| IN    | 65–75 | Px Define      | 39                | Thermal In | -             | -    |
|       | 87    | DI NC/NO Sel   | -                 | -          | -             | -    |

### Motor Overheat Sensor Input Details

| Code                  | Description   |
|-----------------------|---|
| PRT-34 Thermal-T Sel  | The inverter operating status is set when the motor overheats. If Free-Run (1) is set, the inverter output will be blocked. If decelerating stop (2) is set and the overheat sensor detects overheating, the inverter will decelerate and stop.   |
| PRT-35 Thermal In Src | The terminal type is selected when the motor overheat sensor is connected to the voltage (V1) or current (I1) input terminals of the inverter terminal block in the inverter. The voltage (V2) or current (I2) terminals in the I/O expansion module are also available.<br><br>If you use the current input terminal I1 by supplying constant current to the temperature sensor with the analog current output (AO2) terminal, the switch in the I/O expansion module should be where the PTC is. Before use, check if the switch is at the PTC. |

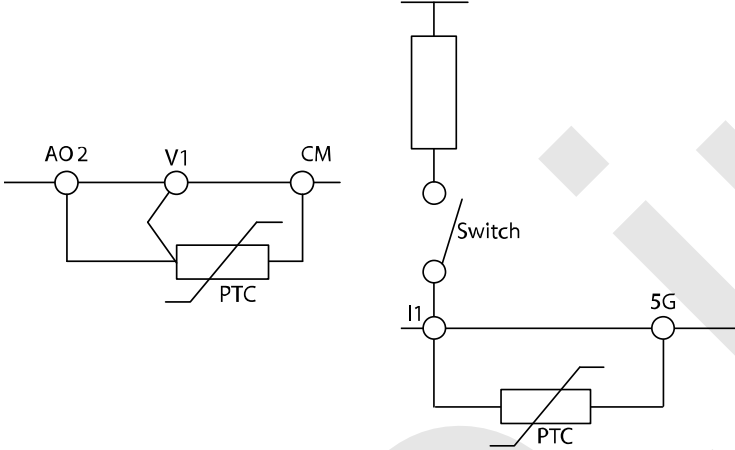
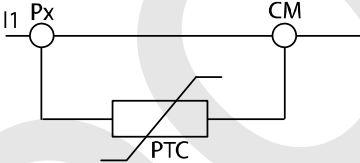
| Code  | Description  |
|---|--|
|   |  <p>[With voltage (V1) input]                      [With current (I1) input terminal]</p> <p>Temperature is measured by letting a certain amount of current flow through the A02 terminal and converting it into voltage depending on the resistance value change.</p>   |
| <p>IN-65-72 Px Define,<br/>IN-82 DI NC/NO Sel</p> | <p>You can set the overheat trip function input using the multi-function terminal block input when using a bimetal-type sensor relay. Connect PTC between the terminal block to use and CM and select “39 (Thermal)” In among the function items. Select the type of contact point of the terminal used in IN-87 as “1 (NC)”.</p>  <p>[Configuration using multi-function input terminals]</p>  |
| <p>PRT-36 Thermal-T<br/>Lev</p>                   | <p>Sets the operation level for the motor overheat sensor. For the voltage input terminal (V1), the maximum input voltage is 10 V and for the current (I1), the maximum input voltage is 5 V. For example, if you use the current input terminal and set the failure level to 50%, the protection function is performed when the voltage supplied to the I1 terminal is below 2.5 V. To perform the protection function when the voltage supplied to the I1 terminal is above 2.5 V, refer to the PRT-37 Thermal-T Area.</p> |
| <p>PRT-37 Thermal-T<br/>Area</p>                  | <p>If Low (0) is set and the motor overheat sensor input is smaller than PRT-36, the protection function is performed. If High (1) is set and the motor overheat sensor input is bigger than PRT-36, the protection function is performed.</p>   |













## 10.2 Inverter and Sequence Protection

## 10.2.1 Open-phase Protection

Open-phase protection is used to prevent overcurrent levels induced at the inverter inputs due to an open-phase within the input power supply. Open-phase output protection is also available. An open phase at the connection between the motor and the inverter may cause the motor to stall, due to a lack of torque.

| Group | Code | LCD Display    | Parameter Setting |    | Setting Range | Unit |
|-------|------|----------------|-------------------|----|---------------|------|
| PRT   | 05   | Phase Loss Chk | -                 | 10 | -             | Bit  |
|       | 06   | IPO V Band     | -                 | 40 | 1–100         | V    |

### Input and Output Open-phase Protection Setting Details

| Code                  | Description  |   |  |                  |                |   |   |  |   |   |   |   |  |   |  |   |   |  |
|-----------------------|--|---|--|------------------|----------------|---|---|--|---|---|---|---|--|---|--|---|---|--|
| PRT-05 Phase Loss Chk | When open-phase protection is operating, input and output configurations are displayed differently. When the LCD segment is On, the corresponding bit is set to 'Off'.   |   |  |                  |                |   |   |  |   |   |   |   |  |   |  |   |   |  |
|                       | <table border="1"> <thead> <tr> <th>Item</th> <th>Bit status (On)</th> <th>Bit status (Off)</th> </tr> </thead> <tbody> <tr> <td>Keypad display</td> <td></td> <td></td> </tr> </tbody> </table>   | Item  | Bit status (On)  | Bit status (Off) | Keypad display |  |  |  |   |   |   |   |  |   |  |   |   |  |
|                       | Item   | Bit status (On)   | Bit status (Off)   |                  |                |   |   |  |   |   |   |   |  |   |  |   |   |  |
|                       | Keypad display   |    |   |                  |                |   |   |  |   |   |   |   |  |   |  |   |   |  |
|                       | <table border="1"> <thead> <tr> <th colspan="2">Setting</th> <th rowspan="2">Keypad display</th> <th rowspan="2">Function</th> </tr> <tr> <th>Bit 2</th> <th>Bit 1</th> </tr> </thead> <tbody> <tr> <td></td> <td>✓</td> <td></td> <td>Output open-phase protection. If one or more than one phase from U, V, and W is open, the inverter output will be blocked and "Out Phase Open" will be displayed on the keypad.</td> </tr> <tr> <td>✓</td> <td></td> <td></td> <td>Input open-phase protection. If one or more phases from R, S, and T are open, the inverter output will be blocked and "In Phase Open" will be displayed on the keypad. Protection against input phase open starts only when a certain amount of current (70–80% of the inverter-rated output current) flows through the motor.</td> </tr> <tr> <td>✓</td> <td>✓</td> <td></td> <td>Input and output open-phase protection</td> </tr> </tbody> </table> | Setting   |  | Keypad display   | Function       | Bit 2   | Bit 1   |  | ✓ |  | Output open-phase protection. If one or more than one phase from U, V, and W is open, the inverter output will be blocked and "Out Phase Open" will be displayed on the keypad. | ✓ |  |  | Input open-phase protection. If one or more phases from R, S, and T are open, the inverter output will be blocked and "In Phase Open" will be displayed on the keypad. Protection against input phase open starts only when a certain amount of current (70–80% of the inverter-rated output current) flows through the motor. | ✓ | ✓ |  |
| Setting               |  | Keypad display  | Function   |                  |                |   |   |  |   |   |   |   |  |   |  |   |   |  |
| Bit 2                 | Bit 1  |   |  |                  |                |   |   |  |   |   |   |   |  |   |  |   |   |  |
|                       | ✓  |  | Output open-phase protection. If one or more than one phase from U, V, and W is open, the inverter output will be blocked and "Out Phase Open" will be displayed on the keypad.  |                  |                |   |   |  |   |   |   |   |  |   |  |   |   |  |
| ✓                     |  |  | Input open-phase protection. If one or more phases from R, S, and T are open, the inverter output will be blocked and "In Phase Open" will be displayed on the keypad. Protection against input phase open starts only when a certain amount of current (70–80% of the inverter-rated output current) flows through the motor. |                  |                |   |   |  |   |   |   |   |  |   |  |   |   |  |
| ✓                     | ✓  |   | Input and output open-phase protection   |                  |                |   |   |  |   |   |   |   |  |   |  |   |   |  |
| PRT-06 IPO V Band     | Sets the band of the allowed ripple voltage. If one or more phases from the inverter output are open, the ripple of the DC link voltage increases. If ripple voltage exceeds the set ripple voltage band, an input phase open trip occurs. The IPO V Band may be adjusted depending on the operating environment.  |   |  |                  |                |   |   |  |   |   |   |   |  |   |  |   |   |  |
|                       | Sets the IPO V Band 1–10 volts higher if the output load is too large for the input capacity, and an open phase fault trip occurs during a normal operation.<br>Sets the IPO V Band 1–10 volts lower if the output load is too smaller for the input capacity.   |   |  |                  |                |   |   |  |   |   |   |   |  |   |  |   |   |  |

**Note**

Ensure that the motor-rated current (BAS-13 Rated Curr) is correctly set. Phase open protection may not be operated properly if the motor's rated current is not correctly set at BAS-13.

### 10.2.2 External Trip Signal

Set one of the multi-function input terminals to "4 (External Trip)" to allow the inverter to stop operation when abnormal operating conditions arise.

| Group | Code  | LCD Display  | Parameter Setting |   | Unit |
|-------|-------|--------------|-------------------|---|------|
| IN    | 65-72 | Px Define    | 4                 | External Trip   | -    |
|       | 87    | DI NC/NO Sel | -                 | <br>(000 000000) | -    |

#### External Trip Signal Setting Details

| Code               | Description  |     |    |    |    |    |    |    |    |    |    |   |   |          |   |   |   |    |    |    |    |    |    |    |    |
|--------------------|--|-----|----|----|----|----|----|----|----|----|----|---|---|----------|---|---|---|----|----|----|----|----|----|----|----|
| IN-87 DI NC/NO Sel | Select the type of input contact. If the mark of the switch is at the bottom (0), it operates as a form A terminal (Normally Open). If the mark is at the top (1), it operates as a form B terminal (Normally Closed).<br><br>The corresponding terminals for each bit are as follows:   |     |    |    |    |    |    |    |    |    |    |   |   |          |   |   |   |    |    |    |    |    |    |    |    |
|                    | <table border="1"> <thead> <tr> <th>Bit</th> <th>11</th> <th>10</th> <th>9</th> <th>8</th> <th>7</th> <th>6</th> <th>5</th> <th>4</th> <th>3</th> <th>2</th> <th>1</th> </tr> </thead> <tbody> <tr> <td>Terminal</td> <td>-</td> <td>-</td> <td>-</td> <td>P8</td> <td>P7</td> <td>P6</td> <td>P5</td> <td>P4</td> <td>P3</td> <td>P2</td> <td>P1</td> </tr> </tbody> </table> | Bit | 11 | 10 | 9  | 8  | 7  | 6  | 5  | 4  | 3  | 2 | 1 | Terminal | - | - | - | P8 | P7 | P6 | P5 | P4 | P3 | P2 | P1 |
| Bit                | 11   | 10  | 9  | 8  | 7  | 6  | 5  | 4  | 3  | 2  | 1  |   |   |          |   |   |   |    |    |    |    |    |    |    |    |
| Terminal           | -  | -   | -  | P8 | P7 | P6 | P5 | P4 | P3 | P2 | P1 |   |   |          |   |   |   |    |    |    |    |    |    |    |    |

External Trip A terminal On 

External Trip B terminal On 

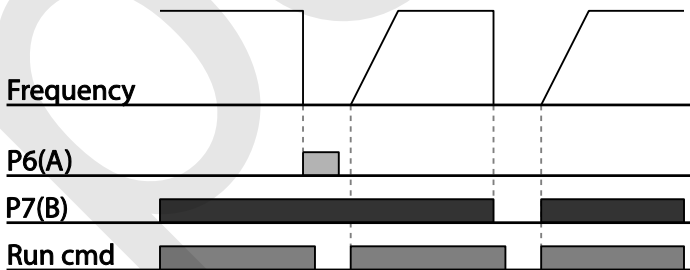

### 10.2.3 Inverter Overload Protection (IOLT)

If more current than the inverter-rated current flows, the protective function starts to protect the inverter depending on the inverse time characteristic.

| Group | Code  | LCD Display   | Parameter Setting |     | Unit |
|-------|-------|---------------|-------------------|-----|------|
| OUT   | 31–33 | Relay 1,2, Q1 | 6                 | IOL | -    |

#### Note

A warning signal output can be provided in advance by the multi-function output terminal before the inverter overload protection function (IOLT) operates. When the overcurrent time reaches 60% of the allowed overcurrent (150%, 1 min), a warning signal output is provided (signal output at 150% for 36 sec).

### 10.2.4 Keypad Command Loss

When setting operation speed using the keypad, speed command loss setting can be used to select the inverter operation for situations when the speed command from the keypad is lost due to the disconnection of signal cable.

| Group | Code  | LCD Display   | Parameter Setting |             | Unit |
|-------|-------|---------------|-------------------|-------------|------|
| PRT   | 11    | Lost KPD Mode | 2                 | Free-Run    | -    |
| OUT   | 31–33 | Relay1,2, Q1  | 30                | Lost Keypad | -    |
| DRV   | 06    | Cmd Source    | 0                 | Keypad      | -    |
| CNF   | 22    | Multi Key Sel | 0                 | JOG Key     | -    |

### Speed Command Loss Setting Details

| Code  | Description   |          |          |   |      |   |         |   |          |   |     |
|---|---|----------|----------|---|------|---|---------|---|----------|---|-----|
| PRT-11 Lost KPD Mode  | Set the DRV-06 (command source) to "0 (keypad)", and select the inverter's operation for when there is a keypad connection problem.   |          |          |   |      |   |         |   |          |   |     |
|   | <table border="1"> <thead> <tr> <th>Setting</th> <th>Function</th> </tr> </thead> <tbody> <tr> <td>0</td> <td>None</td> </tr> <tr> <td>1</td> <td>Warning</td> </tr> <tr> <td>2</td> <td>Free-Run</td> </tr> <tr> <td>3</td> <td>Dec</td> </tr> </tbody> </table> | Setting  | Function | 0 | None | 1 | Warning | 2 | Free-Run | 3 | Dec |
|   | Setting   | Function |          |   |      |   |         |   |          |   |     |
|   | 0   | None     |          |   |      |   |         |   |          |   |     |
|   | 1   | Warning  |          |   |      |   |         |   |          |   |     |
| 2   | Free-Run  |          |          |   |      |   |         |   |          |   |     |
| 3   | Dec   |          |          |   |      |   |         |   |          |   |     |
| The speed command immediately becomes the operation frequency without any protection function.                                      |   |          |          |   |      |   |         |   |          |   |     |
| Set one of the output terminals to "29 (Lost keypad)" to output a relevant warning signal when abnormal operating conditions arise. |   |          |          |   |      |   |         |   |          |   |     |
| The inverter blocks output when the keypad connection is lost. The motor performs in free-run condition.                            |   |          |          |   |      |   |         |   |          |   |     |
| The motor decelerates and then stops at the time set at PRT-07 (Trip Dec Time) when the keypad connection is lost.                  |   |          |          |   |      |   |         |   |          |   |     |



## Using Protection Features

| Code | Description   |
|------|---|
|      | The protection function is also available for the keypad command loss during jog key operation when CNF-22 is set to "JOG Key." |

## 10.2.5 Speed Command Loss

When setting the operation speed using an analog input at the terminal block, communication options, or the keypad, the speed command loss setting can be used to select the inverter operation for situations when the speed command is lost due to the disconnection of signal cables.

The function activates the command loss detection even for the operation command loss through communication.

| Group | Code  | LCD Display   | Parameter Setting |              | Setting Range           | Unit |
|-------|-------|---------------|-------------------|--------------|-------------------------|------|
| PRT   | 12    | Lost Cmd Mode | 1                 | Free-Run     | -                       | -    |
|       | 13    | Lost Cmd Time | -                 | 1.0          | 0.0–120                 | Sec  |
|       | 14    | Lost Preset F | -                 | 0.00         | Starting Freq–Max. Freq | Hz   |
|       | 15    | AI Lost Level | 1                 | Half of X1   | -                       | -    |
| OUT   | 31–33 | Relay1,2, Q1  | 13                | Lost Command | -                       | -    |

### Speed Command Loss Setting Details

| Code                                       | Description  |   |          |                |   |              |   |         |   |                |   |                 |  |                 |   |
|--|--|---|----------|----------------|---|--------------|---|---------|---|----------------|---|-----------------|--|-----------------|---|
| PRT-12 Lost Cmd Mode                       | In situations when speed commands are lost, the inverter can be configured to operate in a specific mode:  |   |          |                |   |              |   |         |   |                |   |                 |  |                 |   |
|  | <table border="1"> <thead> <tr> <th>Setting</th> <th>Function</th> </tr> </thead> <tbody> <tr> <td>0   None</td> <td>The speed command immediately becomes the operation frequency without any protection function.</td> </tr> <tr> <td>1   Free-Run</td> <td>The inverter blocks output. The motor performs in free-run condition.</td> </tr> <tr> <td>2   Dec</td> <td>The motor decelerates and then stops at the time set at PRT-07 (Trip Dec Time).</td> </tr> <tr> <td>3   Hold Input</td> <td>The inverter calculates the average input value for 10 seconds before the loss of the speed command and uses it as the speed reference.</td> </tr> <tr> <td>4   Hold Output</td> <td>The inverter calculates the average output value for 10 seconds before the loss of the speed command and uses it as the speed reference.</td> </tr> <tr> <td>5   Lost Preset</td> <td>The inverter operates at the frequency set at PRT-14 (Lost Preset F).</td> </tr> </tbody> </table> | Setting   | Function | 0   None       | The speed command immediately becomes the operation frequency without any protection function.                        | 1   Free-Run | The inverter blocks output. The motor performs in free-run condition. | 2   Dec | The motor decelerates and then stops at the time set at PRT-07 (Trip Dec Time). | 3   Hold Input | The inverter calculates the average input value for 10 seconds before the loss of the speed command and uses it as the speed reference. | 4   Hold Output | The inverter calculates the average output value for 10 seconds before the loss of the speed command and uses it as the speed reference. | 5   Lost Preset | The inverter operates at the frequency set at PRT-14 (Lost Preset F). |
|  | Setting  | Function  |          |                |   |              |   |         |   |                |   |                 |  |                 |   |
|  | 0   None   | The speed command immediately becomes the operation frequency without any protection function.  |          |                |   |              |   |         |   |                |   |                 |  |                 |   |
|  | 1   Free-Run   | The inverter blocks output. The motor performs in free-run condition.   |          |                |   |              |   |         |   |                |   |                 |  |                 |   |
|  | 2   Dec  | The motor decelerates and then stops at the time set at PRT-07 (Trip Dec Time).   |          |                |   |              |   |         |   |                |   |                 |  |                 |   |
|  | 3   Hold Input   | The inverter calculates the average input value for 10 seconds before the loss of the speed command and uses it as the speed reference. |          |                |   |              |   |         |   |                |   |                 |  |                 |   |
| 4   Hold Output                            | The inverter calculates the average output value for 10 seconds before the loss of the speed command and uses it as the speed reference.   |   |          |                |   |              |   |         |   |                |   |                 |  |                 |   |
| 5   Lost Preset                            | The inverter operates at the frequency set at PRT-14 (Lost Preset F).  |   |          |                |   |              |   |         |   |                |   |                 |  |                 |   |
| PRT-15 AI Lost Level, PRT-13 Lost Cmd Time | Configure the voltage and decision time for speed command loss when using analog input.  |   |          |                |   |              |   |         |   |                |   |                 |  |                 |   |
|  | <table border="1"> <thead> <tr> <th>Setting</th> <th>Function</th> </tr> </thead> <tbody> <tr> <td>0   Half of x1</td> <td>Based on the values set at IN-08 and IN-12, a protective operation starts when the input signal is reduced to half of</td> </tr> </tbody> </table>  | Setting   | Function | 0   Half of x1 | Based on the values set at IN-08 and IN-12, a protective operation starts when the input signal is reduced to half of |              |   |         |   |                |   |                 |  |                 |   |
| Setting                                    | Function   |   |          |                |   |              |   |         |   |                |   |                 |  |                 |   |
| 0   Half of x1                             | Based on the values set at IN-08 and IN-12, a protective operation starts when the input signal is reduced to half of  |   |          |                |   |              |   |         |   |                |   |                 |  |                 |   |

| Code                 | Description   |   |
|----------------------|---|---|
|                      |   | the initial value of the analog input set using the speed command (DRV-01) and it continues for the time (speed loss decision time) set at PRT-13 (Lost Cmd Time). For example, set the speed command to “2 (V1)” at DRV-07, and set IN-06 (V1 Polarity) to “0 (Unipolar)”. When the voltage input drops to less than half of the value set at IN-08 (V1 Volt x 1), the protective function is activated. |
|                      | 1   | Below of x1<br>The protective operation starts when the signal becomes smaller than the initial value of the analog input set by the speed command and it continues for the speed loss decision time set at PRT-13 (Lost Cmd Time). Codes IN-08 and IN-12 are used to set the standard values.  |
| PRT-14 Lost Preset F | In situations where speed commands are lost, set the operation mode (PRT-12 Lost Cmd Mode) to “5 (Lost Preset)”. This operates the protection function and sets the frequency so that the operation can continue. |   |

Set IN-06 (V1 Polarity) to “Unipolar” and IN-08 to “5 (V)”. Set PRT-15 (AI Lost Level) to “1 (Below x1)” and PRT-12 (Lost Cmd Mode) to “2 (Dec)” and then set PRT-13 (Lost Cmd Time) to 5 seconds. Then the inverter operates as follows:

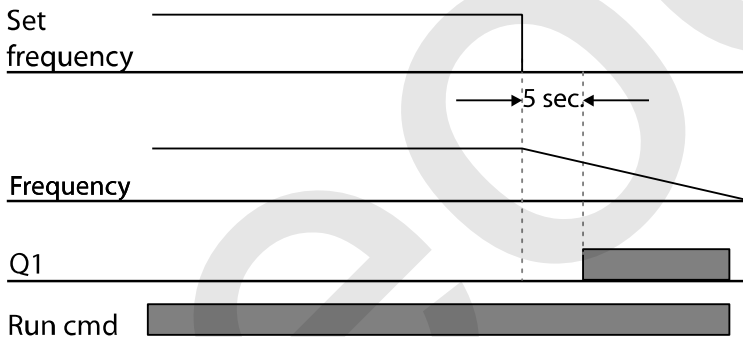

## Note

If speed command is lost while using communication options or the integrated RS-485 communication, the protection function operates after the command loss decision time set at PRT-13 (Lost Cmd Time) is elapsed.

## 10.2.6 Dynamic Braking (DB) Resistor Configuration

The iS7 series is divided into a model which features a built-in braking circuit and the other in which a separate external braking unit should be installed. 0.75–22 kW model types belong to the former (braking resistor unit is excluded) and for those model types above 30 kW, you should install a

braking unit on the exterior of the inverter. Therefore the function of limiting the braking resistance use rate (%ED) is necessary for only models below 22 kW.

| Group | Code  | LCD Display  | Parameter Setting |            | Setting Range | Unit |
|-------|-------|--------------|-------------------|------------|---------------|------|
| PRT   | 66    | DB Warn %ED  | -                 | 10         | 0-30%         | -    |
| OUT   | 31-33 | Relay1,2, Q1 | 31                | DB Warn%ED | -             | -    |

### Dynamic Braking Resistor Setting Details

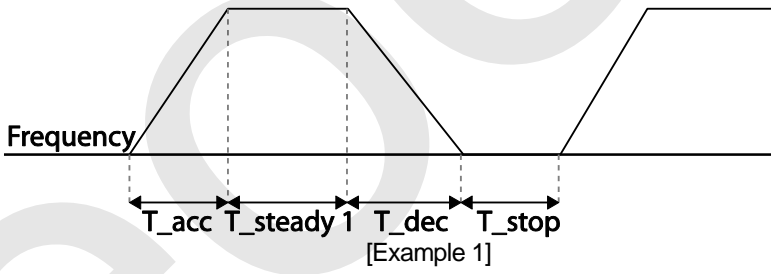
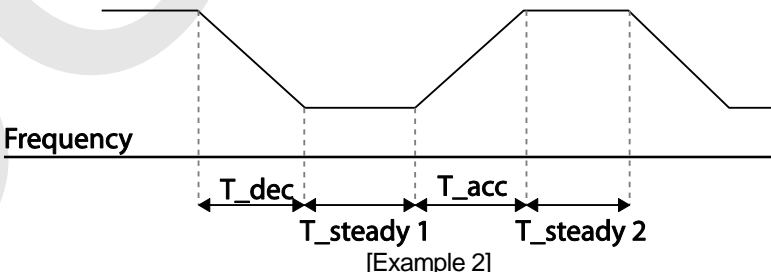
| Code               | Description  |
|--------------------|--|
| PRT-66 DB Warn %ED | <p>Sets braking resistor configuration (%ED: Duty cycle). Braking resistor configuration sets the rate at which the braking resistor operates for one operation cycle. The maximum time for continuous braking is 15 sec and the braking resistor signal is not output from the inverter after the 15 sec period has expired. An example of braking resistor set up is as follows:</p> $\%ED = \frac{T_{dec}}{T_{acc} + T_{steady} + T_{dec} + T_{stop}} \times 100\%$  <p>[Example 1]</p> $\%ED = \frac{T_{dec}}{T_{dec} + T_{steady1} + T_{acc} + T_{steady2}} \times 100\%$  <p>[Example 2]</p> <ul style="list-style-type: none"> <li>• T_acc: Acceleration time to set frequency</li> <li>• T_steady: Constant speed operation time at set frequency</li> <li>• T_dec: Deceleration time to a frequency lower than constant speed</li> </ul> |

| Code | Description  |
|------|--|
|      | operation or the stop time from constant speed operation frequency <ul style="list-style-type: none"> <li>T_stop: Stop time until operation resumes</li> </ul> |

### ⚠ Caution

Do not set the braking resistor to exceed the resistor's power rating. If overloaded, it can overheat and cause a fire. When using a resistor with a heat sensor, the sensor output can be used as an external trip signal for the inverter's multi-function input.

## 10.2.7 Underload Warning and Failure

The following table lists the under load fault trip and warning features of the iS7 series inverter.

| Group | Code | LCD Display  | Parameter Setting |             | Setting Range | Unit |
|-------|------|--------------|-------------------|-------------|---------------|------|
| PRT   | 04   | Load Duty    | 0                 | Normal Duty | -             | -    |
|       | 25   | UL Warn Sel  | 1                 | Yes         | 0-1           |      |
|       | 26   | UL Warn Time | -                 | 10.0        | 0-600.0       | sec  |
|       | 27   | UL Trip Sel  | 1                 | Free-Run    | -             | -    |
|       | 28   | UL Trip Time | -                 | 30.0        | 0-600.0       | sec  |
|       | 29   | UL LF Level  | -                 | 30          | 10-30         | %    |
|       | 30   | UL BF Level  | -                 | 30          | 10-100        | %    |

### Under Load Trip and Warning Setting Details

| Code                                   | Description   |
|--|---|
| PRT-27 UL Trip Sel                     | Sets the inverter operation mode for situations when an under load trip occurs. If "1 (Free-Run)" is set, the output is blocked in an under load fault trip situation. If "2 (Dec)" is set, the motor decelerates and stops when an under load trip occurs.                               |
| PRT-25 UL Warn Sel                     | Select the under load warning options. Set the multi-function output terminals (at OUT-30-32) to "6 (Underload)." The warning signals are output when an under load condition arises.   |
| PRT-29 UL LF Level, PRT-30 UL BF Level | Sets the range necessary for underload detection based on the underload type. Set the underload rate at an operating frequency for the motor-rated slip speed (2x operation), (BAS-12 Rated Slip) at PRT-29. At PRT-30, the under load rate is decided based on the base frequency set at |

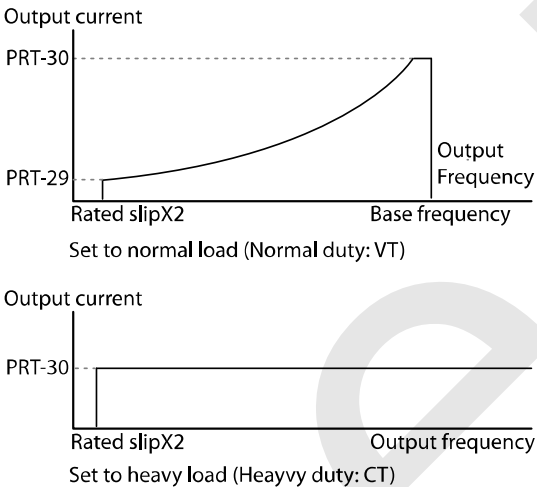
| Code  | Description  |
|---|--|
|   | <p>DRV-18 (Base Freq). When variable torque is required (for example, for fans or pumps), set PRT-04 (Load Duty) to "0 (Normal Duty)." For loads operated at constant torques, like elevators and conveyors, set PRT-04 to "1 (Heavy Duty)."</p>  <p>Output current</p> <p>PRT-30</p> <p>PRT-29</p> <p>Rated slipX2</p> <p>Base frequency</p> <p>Output Frequency</p> <p>Set to normal load (Normal duty: VT)</p> <p>Output current</p> <p>PRT-30</p> <p>Rated slipX2</p> <p>Output frequency</p> <p>Set to heavy load (Heavy duty: CT)</p> |
| <p>PRT-26 UL Warn Time,<br/>PRT-28 UL Trip Time</p> | <p>The protection function operates when the under load level condition explained above is maintained for the set warning time or fault trip time. This function does not operate if the energy-saving operation is activated at ADV-50 (E-SaveMode)</p>   |

### 10.2.8 Overspeed Fault

This function is performed when the control mode (DRV-09 Control Mode) is set to "Sensorless-2", "Vector". If the motor rotates faster than the overspeed level (Over SPD Level) during the overspeed detection time (Over SPD Time), the inverter blocks output.

| Group | Code | LCD Display    | Parameter Setting |       | Unit |
|-------|------|----------------|-------------------|-------|------|
| PRT   | 70   | Over SPD Level | -                 | 120.0 | Hz   |
|       | 72   | Over SPD Time  | -                 | 0.01  | Sec  |

### 10.2.9 Speed Deviation Fault

This function is performed when the control mode (DRV-09 Control Mode) is set to "Vector". If the motor rotates faster than the speed deviation limit (Speed Dev Band) for the set detection time

(Speed Dev Time), the inverter will block output.

| Group | Code | LCD Display    | Parameter Setting |       | Unit |
|-------|------|----------------|-------------------|-------|------|
| PRT   | 73   | Speed Dev Trip | 1                 | Yes   | -    |
|       | 74   | Speed Dev Band | -                 | 20.00 | Hz   |
|       | 75   | Speed Dev Time | -                 | 1.0   | Sec  |

### 10.2.10 Speed Sensor (Encoder) Fault Detection

This function can detect whether the encoder expansion module is installed to the inverter. When the encoder is installed, if the encoder signal cable (line drive type) connection is lost, encoder-related faults are detected. If a fault occurs, a message reading “Encoder Trip” is displayed.

| Group | Code | LCD Display    | Parameter Setting |     | Unit |
|-------|------|----------------|-------------------|-----|------|
| PRT   | 77   | Enc Wire Check | 1                 | Yes | -    |
|       | 78   | Enc Check Time | -                 | 1.0 | sec  |

## 10.2.11 Fan Fault Detection

| Group | Code  | LCD Display   | Parameter Setting |             | Unit |
|-------|-------|---------------|-------------------|-------------|------|
| PRT   | 79    | FAN Trip Mode | 0                 | Trip        | -    |
| OUT   | 31–32 | Relay 1,2     | 8                 | FAN Warning | -    |
|       | 33    | Q1 Define     |                   |             |      |

### Fan Fault Detection Setting Details

| Code                                     | Description   |          |          |        |  |           |   |
|--|---|----------|----------|--------|--|-----------|---|
| PRT-79 Fan Trip Mode                     | Set the cooling fan fault mode.   |          |          |        |  |           |   |
|  | <table border="1"> <thead> <tr> <th>Setting</th> <th>Function</th> </tr> </thead> <tbody> <tr> <td>0 Trip</td> <td>The inverter output is blocked and the fan trip is displayed when a cooling fan error is detected.</td> </tr> <tr> <td>1 Warning</td> <td>When OUT-36 (Q1 Define) or OUT-31–35 (Relay1, 2) is set to “8 (FAN Warning)”, the fan error signal is output and the operation continues.</td> </tr> </tbody> </table> | Setting  | Function | 0 Trip | The inverter output is blocked and the fan trip is displayed when a cooling fan error is detected. | 1 Warning | When OUT-36 (Q1 Define) or OUT-31–35 (Relay1, 2) is set to “8 (FAN Warning)”, the fan error signal is output and the operation continues. |
|  | Setting   | Function |          |        |  |           |   |
| 0 Trip                                   | The inverter output is blocked and the fan trip is displayed when a cooling fan error is detected.  |          |          |        |  |           |   |
| 1 Warning                                | When OUT-36 (Q1 Define) or OUT-31–35 (Relay1, 2) is set to “8 (FAN Warning)”, the fan error signal is output and the operation continues.   |          |          |        |  |           |   |
|  |   |          |          |        |  |           |   |
| OUT-33 Q1 Define,<br>OUT-31–32 Relay1, 2 | When the code value is set to “8 (FAN Warning)”, the fan error signal is output and operation continues. However, when the inverter’s internal temperature rises above a certain level, output is blocked due to activation of overheat protection.   |          |          |        |  |           |   |

## 10.2.12 Low Voltage Fault Trip

| Group | Code  | LCD Display | Parameter Setting |             | Unit |
|-------|-------|-------------|-------------------|-------------|------|
| PRT   | 81    | LVT Delay   | -                 | 0.0         | sec  |
| OUT   | 31–32 | Relay 1,2   | 11                | Low Voltage | -    |
|       | 33    | Q1 Define   |                   |             |      |

### Low Voltage Fault Trip Setting Details

| Code             | Description  |
|------------------|--|
| PRT-81 LVT Delay | When inverter input power is lost and the internal DC link voltage drops below a certain voltage level, the inverter will block the output and a low voltage trip will occur. If the PRT-81 LVT Delay time is set, the inverter blocks output first when a low voltage trip condition arises, then a fault trip will occur after the low voltage trip decision time has passed. The warning signal for a low voltage fault trip can be provided using the multi-function output or a relay. However, the low voltage trip delay time (LVT Delay time) does not apply to warning signals. |



| Code                                  | Description   |
|---------------------------------------|---|
| OUT-33 Q1 Define, OUT-31–32 Relay1, 2 | Set to “11 (Low Voltage)”. The inverter stops the output first when a low voltage trip condition occurs, then a fault trip occurs after the low voltage trip decision time elapses. |

### 10.2.13 Output Block via the Multi-Function Terminal

| Group | Code  | LCD Display | Parameter Setting |     | Setting Range | Unit |
|-------|-------|-------------|-------------------|-----|---------------|------|
| IN    | 65–72 | Px Define   | 5                 | BX  | -             | -    |
| PRT   | 45    | BX Mode     | -                 | 0.0 | 0.0–600.0     |      |

### Output Block by Multi-function Terminal Setting Details

| Code               | Description  |
|--------------------|--|
| IN-65–71 Px Define | When the operation of the multi-function input terminal is set to “5 (BX)” and is turned on during operation, the inverter blocks the output and “BX” is displayed on the keypad display. While “BX” is displayed on the keypad, the inverter’s operation information including the operation frequency and current at the time of the BX signal can be monitored. The inverter resumes operation when the BX terminal turns off and operation command is input.                     |
| PRT-45             | <p>The default setting value of BX mode (PRT-45) is 0.0 [sec], and it allows the inverter to operate in free-run mode. If the BX terminal receives input, the inverter will block output immediately.</p> <p>If BX mode (PRT-45) is set to 0.1 [sec], the motor will decelerate by value set at PRT-45.</p> <p>If PRT-45 set value is too small, the inverter cannot decelerate at that value and OVT may occur. Set the PRT45 time according to the inverter capacity and load.</p> |

### 10.2.14 Trip Status Reset

| Group | Code  | LCD Display | Parameter Setting |     | Unit |
|-------|-------|-------------|-------------------|-----|------|
| IN    | 65-72 | Px Define   | 3                 | RST | -    |

#### Trip Status Reset Setting Details

| Code               | Description  |
|--------------------|--|
| IN-65–72 Px Define | Press the [Stop/Reset] key on the keypad or use the multi-function input terminal to restart the inverter. Set the multi-function input terminal to “3 (RST)” and turn on the terminal to reset the trip status. |

### 10.2.15 Operation Mode On Optional Expansion Module Fault Trip

Optional extension module trips may occur when an optional extension module is used with the inverter. Set the operation mode for the inverter when a communication error occurs between the optional extension module and the inverter body, or when the optional extension module is detached during operation.

| Group | Code | LCD Display   | Parameter Setting |          | Unit       |
|-------|------|---------------|-------------------|----------|------------|
| PRT   | 80   | Opt Trip Mode | 0                 | None     | 1:Free-Run |
|       |      |               | 1                 | Free-Run |            |
|       |      |               | 2                 | Dec      |            |

#### Optional Expansion Module Fault Trip Setting Details

| Code                 | Description    |          |   |
|----------------------|----------------|----------|---|
| PRT-80 Opt Trip Mode | <b>Setting</b> |          | <b>Function</b>   |
|                      | 0              | None     | No operation  |
|                      | 1              | Free-Run | The inverter output is blocked and fault trip information is shown on the keypad. |
|                      | 2              | Dec      | The motor decelerates to the value set at PRT-07 (Trip Dec Time).                 |

### 10.2.16 No Motor Trip

| Group | Code No. | LCD Display    | Parameter Setting |      | Setting Range | Unit |
|-------|----------|----------------|-------------------|------|---------------|------|
| PRT   | 31       | No Motor Trip  | 0                 | None | -             | -    |
|       | 32       | No Motor Level |                   | 5    | 1–100         | %    |
|       | 33       | No Motor Time  |                   | 3.0  | 0.1–10.0      | sec  |

### No Motor Trip Setting Details

| Code   | Description   |
|--|---|
| PRT-32 No Motor Level,<br>PRT-33 No Motor Time | If the output current value [based on the rated current (BAS-13)] is lower than the value set at PRT-32 (No Motor Level), and if this continues for the time set at PRT-33 (No Motor Time), a “no motor trip” occurs. |

#### ⓘ Caution

If BAS-07 (V/F Pattern) is set to “1 (Square)”, set PRT-32 (No Motor Level) to a value lower than the factory default. Otherwise, “No Motor Trip” due to a lack of output current will result when the ‘No Motor Trip’ operation is set.

### 10.2.17 Low Voltage Fault Trip 2 During Operation

| Group | Code | LCD Display  | Parameter Setting range |              | Unit |
|-------|------|--------------|-------------------------|--------------|------|
| PRT   | 82   | Low Voltage2 | 00~11                   | 00 : default | Bit  |





If input power is disconnected during inverter operation and internal DC voltage decreases lower than a certain voltage, the inverter disconnects the output and displays low voltage “2” on the keypad.

Even if the voltage increases and goes back to the normal state, unlike a low voltage fault, it remains in a fault state until the user unlocks the fault state.

If PRT-82 (LV2 Enable) is set to “01,” and if the input power is disconnected during inverter operation and the internal DC voltage drops to lower than a certain voltage, the inverter stops output and displays “Low Voltage2.” Unlike the low voltage trip (Low Voltage), the low voltage 2 (Low Voltage2) trip will not be reset even after the internal DC voltage of the inverter has recovered to above the trip level. Therefore, you must reset the inverter to reset the trip. The trip history will not be stored after the reset.

Set PRT-82 (LV2 Enable) to “11” to store the trip history.

## Low Voltage 2 Trip Details

| Code   | Description   |  |
|--------|---|--|
| PRT-82 | <b>Set options for Low Voltage2 trip operation.</b>                               |  |
|        | Bit setting   | Function   |
|        |  | Disable Low Voltage2 trip (Low Voltage trip is used).        |
|        |  | Enable Low Voltage2 trip. but do not store the trip history. |
|        |  | Disable Low Voltage2 trip (Low Voltage trip is used).        |
|        |  | Enable Low Voltage2 trip and store the trip history.         |

## 10.3 List of Faults and Warnings

The following list shows the types of faults and warnings that can occur while using the iS7 inverter.

| Category    | LCD Display       | Details        |                                |
|-------------|-------------------|----------------|--------------------------------|
| Major fault | Latch type        | Over Current1  | Over current trip              |
|             |                   | Over Voltage   | Over voltage trip              |
|             |                   | External Trip  | Trip due to an external signal |
|             |                   | NTC Open       | Temperature sensor fault trip  |
|             |                   | Over Current2  | ARM short current fault trip   |
|             |                   | Fuse Open      | Fuse open trip                 |
|             |                   | Option Trip-x  | Option fault trip              |
|             |                   | Over Heat      | Over heat fault trip           |
|             |                   | Out Phase Open | Output open-phase fault trip   |
|             |                   | In Phase Open  | Input open-phase fault trip    |
|             |                   | Inverter OLT   | Inverter overload fault trip   |
|             |                   | Over Speed     | Over speed fault trip          |
| Ground Trip | Ground fault trip |                |                                |

| Category    |                 | LCD Display                           | Details                        |
|-------------|-----------------|---------------------------------------|--------------------------------|
|             |                 | Encoder Trip                          | Speed sensor fault trip        |
|             |                 | Fan Trip                              | Fan fault trip                 |
|             |                 | ParaWrite Trip                        | Write parameter fault trip     |
|             |                 | E-Thermal                             | Motor overheat fault trip      |
|             |                 | Thermal Trip                          | Temperature fault trip         |
|             |                 | Pre-PID Fail                          | Pre-PID operation fault trip   |
|             |                 | IO Board Trip                         | IO Board connection fault trip |
|             |                 | Speed Dev Trip                        | Trip from speed deviation      |
|             |                 | Ext-Brake                             | External brake fault trip      |
|             |                 | No Motor Trip                         | No motor fault trip            |
|             | Level type      | Low Voltage                           | Low voltage fault trip         |
|             |                 | BX                                    | Emergency stop fault trip      |
|             |                 | Lost Command                          | Command loss trip              |
|             |                 | Lost Keypad                           | Lost-keypad fault trip         |
|             | Hardware damage | EEP Err                               | External memory error          |
|             |                 | ADC Off Set                           | Analog input error             |
|             |                 | Watch Dog-1                           | CPU Watch Dog fault trip       |
|             |                 | Watch Dog-2                           |                                |
|             |                 | Gate Pwr Loss                         | DRV operation power error      |
| Minor fault | Over Load       | Motor overload trip                   |                                |
|             | Under Load      | Motor under load trip                 |                                |
|             | Lost Command    | Lost command fault trip               |                                |
|             | Lost Keypad     | Lost keypad fault trip                |                                |
| Warning     | Lost Command    | Command loss fault trip warning       |                                |
|             | Over Load       | Overload warning                      |                                |
|             | Under Load      | Under load warning                    |                                |
|             | Inverter OLT    | Inverter overload warning             |                                |
|             | Fan Warning     | Fan operation warning                 |                                |
|             | DB Warn %ED     | Braking resistor braking rate warning |                                |
|             | Enc Conn Check  | Enc connection error warning          |                                |
|             | Enc Dir Check   | Rotating direction error warning      |                                |

| Category | LCD Display   | Details                          |
|----------|---------------|----------------------------------|
|          | Lost Keypad   | Lost keypad warning              |
|          | Retry Tr Tune | Rotor time constant tuning error |
|          | Fire Mode     | Fire mode warning                |
|          | PID Sleep     | PID Sleep mode warning           |
|          | AUX Power On  | AUX Power On warning             |

# 11 Communication Function

## 11.1 Introduction

This chapter explains the standards, installation process, and programs for the SV-iS7 inverter serial communication method when using personal computers or factory automation (FA) computers. The communication function for the SV-iS7 inverter series is designed to remotely operate or monitor the SV-iS7 inverter series using personal computers or FA computers.

### Advantages of Operating the Inverter with Network Communication

As the inverter can be operated or monitored by the user programs, it is easy to apply the inverter to factory automation.

| Features                                    | Examples of application  |
|---|--|
| Monitor or modify parameters via computers  | <ul style="list-style-type: none"> <li>• T_acc</li> <li>• T_dec</li> <li>• Frequency</li> <li>• Lost command</li> </ul>  |
| Interface configuration for RS-485 standard | <ul style="list-style-type: none"> <li>• Performs communication between the inverter and computers produced by numerous companies.</li> <li>• Controls up to 16 inverters at a time with one computer using the multi-drop link system.</li> <li>• Provides an interface for noise immunity environments.</li> </ul> |

Inverters can communicate with computers embedded with the RS-232 module via RS-232/485 converters. The standards and performance of converters may vary depending on the manufacturer, but the basic functions are the same. For more details about standards and guidelines, users are advised to consult the manual provided by the specific manufacturer.

#### ⚠ Caution

Read this manual carefully before installation and operation. All instructions in this manual must be followed to avoid injury or prevent damage to other components.

## 11.2 Specifications

| Category                      | Specifications  |
|-------------------------------|---|
| Communication method          | RS-485  |
| Transfer form                 | Bus type, Multi-drop link system  |
| Inverter type name            | SV-iS7 series   |
| Converter                     | Embedded with RS-232  |
| Number of connected inverters | Maximum of 16   |
| Transfer distance             | Maximum 1,200 m (recommended distance: within 700 m)  |
| Recommended cable size        | 0.75 mm <sup>2</sup> , (18AWG), Shielded twisted-pair (STP) wire  |
| Installation type             | Dedicated terminals (S+/S-/SG) on the control terminal block  |
| Communication Power           | Supplied by the inverter - insulated power source from the inverter's internal circuit communication power (supplied from the inverter) |
| Communication Speed           | 1,200/2,400/9,600/19,200/38,400 bps   |
| Control procedure             | Asynchronous communications system  |
| Communication system          | Half duplex system  |
| Letter system                 | Modbus-RTU: BINARY/LS Bus: ASCII  |
| Stop bit length               | 1-bit/2-bit   |
| Sum check                     | 2 byte  |
| Parity check                  | None/Even/Odd   |



## 11.3 Communication System Configuration

In an RS-485 communication system, the PLC or computer is the master device and the inverter is the slave device. When using a computer as the master, the RS-232 converter must be integrated with the computer, so that it can communicate with the inverter through the RS-232/RS-485 converter. Specifications and performance of converters may vary depending on the manufacturer, but the basic functions are identical. Please refer to the converter manufacturer's user manual for details about features and specifications.

Connect the wires and configure the communication parameters on the inverter by referring to the following illustration of the communication system configuration.

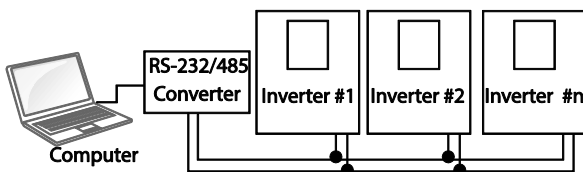

- RS-485 terminal connection: Connect the RS-485 communication line to the S+/S-/SG terminals.
- Number of connectable inverters: Up to 16 inverters
- Number of extendable addresses (St ID): 1–250 addresses
- Length of effective communication lines: 1,200 m max. Keep it below 700 m for stable communication.

### ⚠ Caution

When wiring the communication line, make sure that the SG terminals on the PLC and inverter are connected. SG terminals prevent communication errors due to electronic noise interference.

Use a communication repeater to enhance the communication speed if you have to use a communication cable above 1,200 m, or to connect an additional inverter. A repeater is effective when smooth communication is not available due to noise interference.

## 11.4 Basic Settings

Before proceeding with setting communication configurations, make sure that the communication lines are connected properly. Turn on the inverter and set the communication parameters.

| Group | Code | LCD Display  | Parameter Setting |              | Setting Range | Unit |
|-------|------|--------------|-------------------|--------------|---------------|------|
| COM   | 01   | Int485 St ID | -                 | 1            | 1–250         | -    |
|       | 02   | Int485 Proto | 0                 | ModBus RTU   | 0–3           | -    |
|       | 03   | Int485 BaudR | 3                 | 9600         | 0–5           | bps  |
|       | 04   | Int485 Mode  | 0                 | D8 / PN / S1 | 0–3           | -    |
|       | 05   | Resp Delay   | -                 | 5            | 0–1000        | ms   |

### Communication Parameters Setting Details

| Code                | Description   |  |  |  |   |            |   |   |          |  |   |            |  |   |          |                                      |
|---------------------|---|--|--|--|---|------------|---|---|----------|--|---|------------|--|---|----------|--------------------------------------|
| COM-01 Int485 St ID | Sets the inverter station ID between 1 and 250.   |  |  |  |   |            |   |   |          |  |   |            |  |   |          |                                      |
| COM-02 Int485 Proto | Select one of the two built-in protocols: Modbus-RTU and LS INV 485   |  |  |  |   |            |   |   |          |  |   |            |  |   |          |                                      |
|                     | <table border="1"> <thead> <tr> <th>Setting</th> <th colspan="2">Function</th> </tr> </thead> <tbody> <tr> <td>0</td> <td>Modbus-RTU</td> <td>Modbus-RTU compatible protocol</td> </tr> <tr> <td>1</td> <td>Reserved</td> <td>Not used</td> </tr> <tr> <td>2</td> <td>LS INV 485</td> <td>Dedicated protocol for the LS inverter</td> </tr> </tbody> </table>   | Setting                                | Function                                   |  | 0 | Modbus-RTU | Modbus-RTU compatible protocol            | 1 | Reserved | Not used                                   | 2 | LS INV 485 | Dedicated protocol for the LS inverter |   |          |                                      |
|                     | Setting   | Function                               |  |  |   |            |   |   |          |  |   |            |  |   |          |                                      |
|                     | 0   | Modbus-RTU                             | Modbus-RTU compatible protocol             |  |   |            |   |   |          |  |   |            |  |   |          |                                      |
| 1                   | Reserved  | Not used                               |  |  |   |            |   |   |          |  |   |            |  |   |          |                                      |
| 2                   | LS INV 485  | Dedicated protocol for the LS inverter |  |  |   |            |   |   |          |  |   |            |  |   |          |                                      |
|                     |   |  |  |  |   |            |   |   |          |  |   |            |  |   |          |                                      |
| COM-03 Int485 BaudR | Sets a communication setting speed of up to 38,400 bps.   |  |  |  |   |            |   |   |          |  |   |            |  |   |          |                                      |
| COM-04 Int485 Mode  | Set a communication configuration. Set the data length, parity check method, and the number of stop bits.   |  |  |  |   |            |   |   |          |  |   |            |  |   |          |                                      |
|                     | <table border="1"> <thead> <tr> <th>Setting</th> <th colspan="2">Function</th> </tr> </thead> <tbody> <tr> <td>0</td> <td>D8/PN/S1</td> <td>8-bit data / no parity check / 1 stop bit</td> </tr> <tr> <td>1</td> <td>D8/PN/S2</td> <td>8-bit data / no parity check / 2 stop bits</td> </tr> <tr> <td>2</td> <td>D8/PE/S1</td> <td>8-bit data / even parity / 1 stop bit</td> </tr> <tr> <td>3</td> <td>D8/PO/S1</td> <td>8-bit data / odd parity / 1 stop bit</td> </tr> </tbody> </table> | Setting                                | Function                                   |  | 0 | D8/PN/S1   | 8-bit data / no parity check / 1 stop bit | 1 | D8/PN/S2 | 8-bit data / no parity check / 2 stop bits | 2 | D8/PE/S1   | 8-bit data / even parity / 1 stop bit  | 3 | D8/PO/S1 | 8-bit data / odd parity / 1 stop bit |
|                     | Setting   | Function                               |  |  |   |            |   |   |          |  |   |            |  |   |          |                                      |
|                     | 0   | D8/PN/S1                               | 8-bit data / no parity check / 1 stop bit  |  |   |            |   |   |          |  |   |            |  |   |          |                                      |
|                     | 1   | D8/PN/S2                               | 8-bit data / no parity check / 2 stop bits |  |   |            |   |   |          |  |   |            |  |   |          |                                      |
| 2                   | D8/PE/S1  | 8-bit data / even parity / 1 stop bit  |  |  |   |            |   |   |          |  |   |            |  |   |          |                                      |
| 3                   | D8/PO/S1  | 8-bit data / odd parity / 1 stop bit   |  |  |   |            |   |   |          |  |   |            |  |   |          |                                      |
|                     |   |  |  |  |   |            |   |   |          |  |   |            |  |   |          |                                      |
|                     |   |  |  |  |   |            |   |   |          |  |   |            |  |   |          |                                      |
|                     |   |  |  |  |   |            |   |   |          |  |   |            |  |   |          |                                      |
| COM-05 Resp Delay   | The built-in 485 communication (Modbus-RTU or LS INV 485) device performs as a slave. The slave iS7 responds to the master after the period of time set in this function code.  |  |  |  |   |            |   |   |          |  |   |            |  |   |          |                                      |

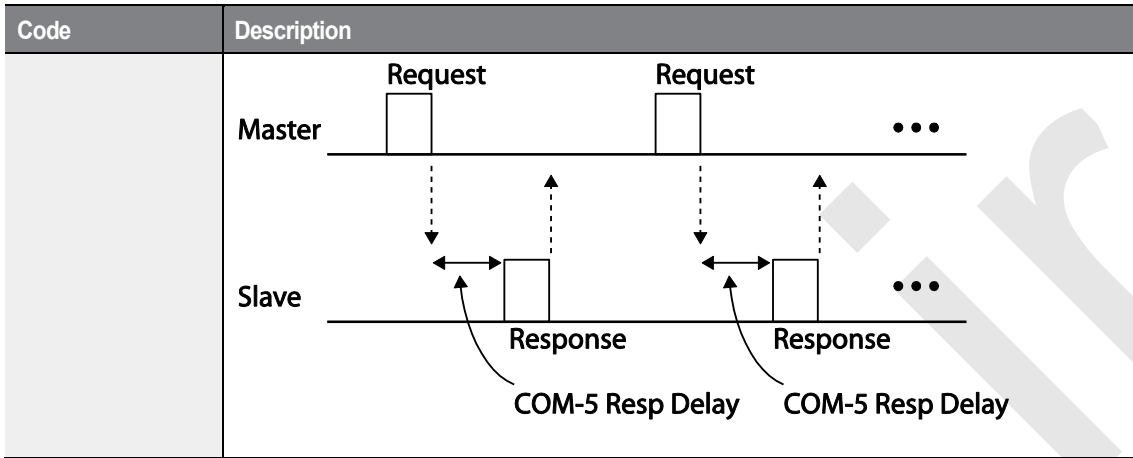

## 11.5 Setting Operation Command and Frequency

After setting the DRV-06 (Cmd Source) to “3 (Int 485)” and DRV-07 (Freq Ref Src) to “7 (Int 485),” you can set common area parameters for the operation command and frequency via communication.

| Group | Code | LCD Display  | Parameter Setting |         | Unit |
|-------|------|--------------|-------------------|---------|------|
| DRV   | 06   | Cmd Source   | 3                 | Int 485 | -    |
|       | 07   | Freq Ref Src | 7                 | Int 485 | -    |

## 11.6 Command Loss Protection

Configure the command loss decision standards and protective operations run when a communication problem lasts for a specified period of time.

| Group | Code  | LCD Display   | Parameter Setting |              | Unit |
|-------|-------|---------------|-------------------|--------------|------|
| PRT   | 12    | Lost Cmd Mode | 1                 | Free-Run     | -    |
|       | 13    | Lost Cmd Time | -                 | 1.0          | Sec  |
|       | 14    | Lost Preset F | -                 | 0.00         | Hz   |
| OUT   | 31-33 | Relay1,2, Q1  | 12                | Lost Command | -    |

## Command Loss Protective Operation Setting Details

| Code  | Description  |   |   |
|---|--|---|---|
| PRT-12 Lost Cmd Mode,<br>PRT-13 Lost Cmd Time | Select the operation to run when a communication error has occurred and lasted exceeding the time set at PRT-13. |   |   |
|   | Setting  | Function  |   |
|   | 0  | None  | The speed command immediately becomes the operation frequency without any protection function.  |
|   | 1  | Free-Run  | The inverter blocks output. The motor performs in free-run condition.   |
|   | 2  | Dec   | The motor decelerates and then stops.   |
|   | 3  | Hold Input  | Operates continuously with the speed of the inputted speed command until the loss of the speed command. The inverter calculates the average input value for 10 seconds before the loss of the speed command and uses it as the speed reference. |
|   | 4  | Hold Output   | Operates continuously with the operate frequency before the speed loss. The inverter calculates the average output value for 10 seconds before the loss of the speed command and uses it as the speed reference.                                |
| 5   | Lost Preset  | The inverter operates at the frequency set at PRT-14 (Lost Preset F). |   |
| PRT-14 Lost Preset F                          | Set the Lost Preset frequency that will be applied if PRT-12 (Lost Cmd Mode) is set to "5 (Lost Preset)."        |   |   |

Caution) If PRT-13 (Lost Cmd Time) is set to "0.0" (sec), protection features may be activated even during a normal operation, depending on the type of command source. To prevent this, appropriately set the lost command decision time.

## 11.7 Setting Virtual Multi-Function inputs

Multi-function input can be controlled using a communication address (0h0385). Set codes COM-70–85 to the functions to operate, and then set the BIT relevant to the function to 1 at 0h0385 to operate it.

| Group | Code  | LCD Display    | Parameter Setting |      | Unit |
|-------|-------|----------------|-------------------|------|------|
| COM   | 70-85 | Virtual DI x   | 0                 | None | -    |
|       | 86    | Virt DI Status | -                 | -    | -    |

For example, if you want to send an Fx command by controlling a virtual multi-function input command addresses with Int485, the Fx function is performed if 0h0001 is input in 0h0385 after COM-70 (Virtual DI 1) is set to "FX". Before you configure the virtual multi-function inputs, set the DRV-06 (CMD source) depending on the command source.

Virtual multi-function operates independently from the analog multi-function inputs and cannot be set redundantly. Virtual multi-function input can be monitored using COM-86 (Virt DI Status).

## 11.8 Saving Parameters Defined by Communication

If you turn off the inverter after setting the common area parameters or keypad parameters via communication and operate the inverter, the changes are lost and the values changed via communication revert to the previous setting values when you turn on the inverter.

Set CNF-48 to “1 (Yes)” to allow all the changes over communication to be saved, so that the inverter retains all the existing values even after the power has been turned off.

Setting address 0h03E0 to “0” and then setting it again to “1” via communication allows the existing parameter settings to be saved. However, setting address 0h03E0 to “1” and then setting it to “0” does not carry out the same function.

Before reading the parameters utilizing CNF-46 (Parameter Read), make sure to save the parameter changes (Parameter Save) to read the parameter values reflecting the changes in the communication module parameters.

| Group | Code | LCD Display    | Setting Display |       | Unit |
|-------|------|----------------|-----------------|-------|------|
| CNF   | 48   | Parameter Save | 0               | -No-  | -    |
|       |      |                | 1               | -Yes- | -    |

## 11.9 Communication Frame Monitoring

You can easily monitor the status (normal, CRC/Checksum error, other errors, etc.) of the communication frame being received from the master by using the keypad.

| Group | Code | LCD Display   | Setting Display |         | Unit |
|-------|------|---------------|-----------------|---------|------|
| COM   | 90   | Comm Mon Sel  | 0               | Int 485 | -    |
|       | 91   | Rcv Frame Num | -               | -       | -    |
|       | 92   | Err Frame Num | -               | -       | -    |
|       | 93   | NAK Frame Num | -               | -       | -    |
|       | 94   | Comm Update   | 0               | -No-    | -    |
| 1     |      |               | -Yes-           |         |      |

### Communication Frame Monitoring Details

| Code                 | Description   |
|----------------------|---|
| COM-90 Comm Mon Sel  | Selects the communication channel to monitor.   |
| COM-91 Rcv Frame Num | Counts the number of communication frames received normally from the master device.   |
| COM-92 Err Frame Num | Counts the number of CRC errors when the Modbus-RTU is set and counts Checksum errors when the LS Inv 485 is set.   |
| COM-93 NAK Frame Num | Counts the number of errors (communication address errors, data range errors, writing prohibition errors) that occur in the communication frames received from the master device. |
| COM-94 Comm Update   | Reconnects the communication after the initial status parameter is changed to communication speed (baud rate), etc.   |

## 11.10 Special communication Area Settings

The following table lists the memory map of the entire memory addresses used for network communication in the iS7 series inverters.

| Communication Area                       | Memory Map      | Description                           |
|--|-----------------|---------------------------------------|
| Common iS5 compatible communication area | 0h0000 - 0h00FF | Area compatible with iS5              |
| Parameter registration type area         | 0h0100 - 0h01FF | Area registered in COM31~46, COM51~66 |

| Communication Area               | Memory Map      | Description                    |
|----------------------------------|-----------------|--------------------------------|
|                                  | 0h0200 - 0h023F | Area registered in User Group  |
|                                  | 0h0240 - 0h027F | Area registered in Macro Group |
|                                  | 0h0280 - 0h02FF | Reserved                       |
| Common iS7<br>communication area | 0h0300 - 0h037F | Inverter monitoring area       |
|                                  | 0h0380 - 0h03DF | Inverter control area          |
|                                  | 0h03E0 - 0h03FF | Inverter memory control area   |
|                                  | 0h0400 - 0h0FFF | Reserved                       |
|                                  | 0h1100          | DRV Grp                        |
|                                  | 0h1200          | BAS Grp                        |
|                                  | 0h1300          | ADV Grp                        |
|                                  | 0h1400          | CON Grp                        |
|                                  | 0h1500          | IN Grp                         |
|                                  | 0h1600          | OUT Grp                        |
|                                  | 0h1700          | COM Grp                        |
|                                  | 0h1800          | APP Grp                        |
|                                  | 0h1A00          | APO Grp                        |
|                                  | 0h1B00          | PRT Grp                        |
|                                  | 0h1C00          | M2 Grp                         |

## 11.11 Parameter Group for Periodical Data Transmission

By defining a parameter group for data transmission, the communication addresses registered in the communication function group (CM) can be used in communication. Parameter groups for data transmission may be defined to simultaneously transmit multiple parameters into the communication frame.

| Group | Code No. | Function Display | Setting Display |   | Unit |
|-------|----------|------------------|-----------------|---|------|
| COM   | 31-46    | Para Status-h    | -               | - | Hex  |
|       | 51-66    | Para Control-h   | -               | - | Hex  |

**Parameter Group for Periodical Data Transmission Details**

| Addresses     | Description  |                                      |                                      |
|---------------|--|--------------------------------------|--------------------------------------|
| 0h0100–0h010F | Reads the parameter registered in COM-31~46 Status Para-h (read only).                       |                                      |                                      |
|               | <b>Address</b>   | <b>Parameter</b>                     | <b>Allotment for Bits</b>            |
|               | 0h0100   | Status Parameter #1                  | Parameter value registered at COM-31 |
|               | 0h0101   | Status Parameter #2                  | Parameter value registered at COM-32 |
|               | 0h0102   | Status Parameter #3                  | Parameter value registered at COM-33 |
|               | 0h0103   | Status Parameter #4                  | Parameter value registered at COM-34 |
|               | 0h0104   | Status Parameter #5                  | Parameter value registered at COM-35 |
|               | 0h0105   | Status Parameter #6                  | Parameter value registered at COM-36 |
|               | 0h0106   | Status Parameter #7                  | Parameter value registered at COM-37 |
|               | 0h0107   | Status Parameter #8                  | Parameter value registered at COM-38 |
|               | 0h0108   | Status Parameter #9                  | Parameter value registered at COM-39 |
|               | 0h0109   | Status Parameter #10                 | Parameter value registered at COM-40 |
|               | 0h010A   | Status Parameter #11                 | Parameter value registered at COM-41 |
|               | 0h010B   | Status Parameter #12                 | Parameter value registered at COM-42 |
|               | 0h010C   | Status Parameter #13                 | Parameter value registered at COM-43 |
|               | 0h010D   | Status Parameter #14                 | Parameter value registered at COM-44 |
|               | 0h010E   | Status Parameter #15                 | Parameter value registered at COM-45 |
| 0h010F        | Status Parameter #16   | Parameter value registered at COM-46 |                                      |
| 0h0110–0h011F | Reads and writes the parameter registered in COM-51~66 Control Para-h (both read and write). |                                      |                                      |
|               | <b>Address</b>   | <b>Parameter</b>                     | <b>Allotment for Bits</b>            |
|               | 0h0110   | Control Parameter #1                 | Parameter value registered at COM-51 |
|               | 0h0111   | Control Parameter #2                 | Parameter value registered at COM-52 |
|               | 0h0112   | Control Parameter #3                 | Parameter value registered at COM-53 |
|               | 0h0113   | Control Parameter #4                 | Parameter value registered at COM-54 |
|               | 0h0114   | Control Parameter #5                 | Parameter value registered at COM-55 |
|               | 0h0115   | Control Parameter #6                 | Parameter value registered at COM-56 |
|               | 0h0116   | Control Parameter #7                 | Parameter value registered at COM-57 |
|               | 0h0117   | Control Parameter #8                 | Parameter value registered at COM-58 |
|               | 0h0118   | Control Parameter #9                 | Parameter value registered at COM-59 |
|               | 0h0119   | Control Parameter #10                | Parameter value registered at COM-60 |
|               | 0h011A   | Control Parameter #11                | Parameter value registered at COM-61 |
|               | 0h011B   | Control Parameter #12                | Parameter value registered at COM-62 |
|               | 0h011C   | Control Parameter #13                | Parameter value registered at COM-63 |
|               | 0h011D   | Control Parameter #14                | Parameter value registered at COM-64 |
|               | 0h011E   | Control Parameter #15                | Parameter value registered at COM-65 |
| 0h011F        | Control Parameter #16  | Parameter value registered at COM-66 |                                      |



**ⓘ Caution**

When registering control parameters, register the operation speed (0h0005, 0h0380, 0h0381) and operation command (0h0006, 0h0382) parameters at the end of a parameter control frame. For example, when the parameter control frame has 5 parameter control items (Para Control - x), register the operation speed at Para Control-4 and the operation command to Para Control-5.

## 11.12 Parameter Group for Transmission of Macro Group and User Group at U&M Mode

By defining the user and macro parameter groups, communication can be carried out using the user defined user group (USR) and macro group (MAC) addresses that are registered in U&M mode.

| Addresses                         | Description   |   |   |
|-----------------------------------|---|---|---|
| U&M>USR-1~64<br>User Grp. Para h  | Writes and reads the USR parameters set by the keypad via the addresses 0h0200~0h023F.  |   |   |
|                                   | Address   | Parameter                                 | Allotment for Bits                        |
|                                   | 0h0200  | User Grp. Code 1                          | Parameter value registered at U&M>USR->1  |
|                                   | 0h0201  | User Grp. Code 2                          | Parameter value registered at U&M>USR->2  |
|                                   | ...   | ...                                       | ...                                       |
|                                   | 0h023E  | User Grp. Code 63                         | Parameter value registered at U&M>USR->63 |
| 0h023F                            | User Grp. Code 64   | Parameter value registered at U&M>USR->64 |   |
| U&M>MAC-1~64<br>Macro Grp. Para h | Writes and reads the Macro parameters set by the keypad via the addresses 0h2400~0h2A3. |   |   |
|                                   | Address   | Parameter                                 | Allotment for Bits                        |
|                                   | 0h0240  | Macro Grp. Code 1                         | Parameter value registered at U&M>MAC-1   |
|                                   | 0h0241  | Macro Grp. Code 2                         | Parameter value registered at U&M>MAC-2   |
|                                   | ...   | ...                                       | ...                                       |
|                                   | 0h02A2  | Macro Grp. Code 63                        | Parameter value registered at U&M>MAC-63  |
| 0h02A3                            | Macro Grp. Code 64  | Parameter value registered at U&M>MAC-64  |   |

## 11.13 Communication Protocol

### 11.13.1 LS INV 485 Protocol

The slave device (inverter) responds to read and write requests from the master device (PLC or PC).

### Request

| ENQ    | Station ID | CMD    | Data    | SUM     | EOT    |
|--------|------------|--------|---------|---------|--------|
| 1 byte | 2 bytes    | 1 byte | n bytes | 2 bytes | 1 byte |

### Normal Response

| ACK    | Station ID | CMD    | Data        | SUM     | EOT    |
|--------|------------|--------|-------------|---------|--------|
| 1 byte | 2 bytes    | 1 byte | n x 4 bytes | 2 bytes | 1 byte |

### Error Response

| NAK    | Station ID | CMD    | Error code | SUM     | EOT    |
|--------|------------|--------|------------|---------|--------|
| 1 byte | 2 bytes    | 1 byte | 2 bytes    | 2 bytes | 1 byte |

- A request starts with ENQ and ends with EOT.
- A normal response starts with ACK and ends with EOT.
- An error response starts with NAK and ends with EOT.
- A station ID indicates the inverter number and is displayed as a two-byte ASCII-HEX string that uses characters 0-9 and A-F.
- CMD: Uses uppercase characters (returns an IF error if lowercase characters are encountered).

| Character | ASCII-HEX | Command                      |
|-----------|-----------|------------------------------|
| 'R'       | 52h       | Read                         |
| 'W'       | 57h       | Write                        |
| 'X'       | 58h       | Request monitor registration |
| 'Y'       | 59h       | Perform monitor registration |

- Data: ASCII-HEX (for example, when the data value is 3000: 3000 → '0"B"B"8'h → 30h 42h 42h 38h)
- Error code: ASCII-HEX (20h–7Fh)
- Transmission/reception buffer size: Transmission=39 bytes, Reception=44 bytes
- Monitor registration buffer: 8 Words
- SUM: Checks communication errors via sum.
- SUM=a total of the lower 8 bits values for station ID, command and data (Station ID+CMD+Data) in ASCII-HEX.
- For example, a command to read 1 address from address 3000:  
 $SUM = '0' + '1' + 'R' + '3' + '0' + '0' + '0' + '1' = 30h + 31h + 52h + 33h + 30h + 30h + 30h + 31h = 1A7h$  (the control value is not included: ENQ, ACK, NAK, etc.)

| ENQ    | Station ID | CMD    | Address | Number of Addresses | SUM     | EOT    |
|--------|------------|--------|---------|---------------------|---------|--------|
| 05h    | '01'       | 'R'    | '3000'  | '1'                 | 'A7'    | 04h    |
| 1 byte | 2 bytes    | 1 byte | 4 bytes | 1 byte              | 2 bytes | 1 byte |

### Note

#### Broadcasting

Broadcasting sends commands to all inverters connected to the network simultaneously. When commands are sent from station ID 255, each inverter acts on the command regardless of the station ID. However no response is issued for commands transmitted by broadcasting.

#### Error operation

For two or more data communications, when an error occurs as a result of the previous data communication, the current data communication can be made normally regardless of the error occurred as a result of the previous data communication.

## 11.13.1.1 Detailed Read Protocol

### Read Request

Reads successive n words from address XXXX.

| ENQ    | Station ID | CMD    | Address | Number of Addresses | SUM     | EOT    |
|--------|------------|--------|---------|---------------------|---------|--------|
| 05h    | '01'-'1F'  | 'R'    | 'XXXX'  | '1'-'8' = n         | 'XX'    | 04h    |
| 1 byte | 2 bytes    | 1 byte | 4 bytes | 1 byte              | 2 bytes | 1 byte |

Total bytes=12. Characters are displayed inside single quotation marks(').

### Read Normal Response

| ACK    | Station ID | CMD    | Data        | SUM     | EOT    |
|--------|------------|--------|-------------|---------|--------|
| 06h    | '01'-'1F'  | 'R'    | 'XXXX'      | 'XX'    | 04h    |
| 1 byte | 2 bytes    | 1 byte | n x 4 bytes | 2 bytes | 1 byte |

Total bytes= (7 x n x 4); a maximum of 39

### Read Error Response

| NAK | Station ID | CMD | Error code | SUM  | EOT |
|-----|------------|-----|------------|------|-----|
| 15h | '01'-'1F'  | 'R' | '**'       | 'XX' | 04h |

| NAK    | Station ID | CMD    | Error code | SUM     | EOT    |
|--------|------------|--------|------------|---------|--------|
| 1 byte | 2 bytes    | 1 byte | 2 bytes    | 2 bytes | 1 byte |

Total bytes=9

### 11.13.1.2 Detailed Write Protocol

#### Write Request

| ENQ    | Station ID | CMD    | Address | Number of Addresses | Data        | SUM     | EOT    |
|--------|------------|--------|---------|---------------------|-------------|---------|--------|
| 05h    | '01'-'1F'  | 'W'    | 'XXXX'  | '1'-'8' = n         | 'XXXX...'   | 'XX'    | 04h    |
| 1 byte | 2 bytes    | 1 byte | 4 bytes | 1 byte              | n x 4 bytes | 2 bytes | 1 byte |

Total bytes= (12 + n x 4): a maximum of 44

#### Write Normal Response

| ACK    | Station ID | CMD    | Data        | SUM     | EOT    |
|--------|------------|--------|-------------|---------|--------|
| 06h    | '01'-'1F'  | 'W'    | 'XXXX...'   | 'XX'    | 04h    |
| 1 byte | 2 bytes    | 1 byte | n x 4 bytes | 2 bytes | 1 byte |

Total bytes= (7 + n x 4): a maximum of 39

#### Write Error Response

| NAK    | Station ID | CMD    | Error Code | SUM     | EOT    |
|--------|------------|--------|------------|---------|--------|
| 15h    | '01'-'1F'  | 'W'    | ***        | 'XX'    | 04h    |
| 1 byte | 2 bytes    | 1 byte | 2 bytes    | 2 bytes | 1 byte |

Total bytes=9

### 11.13.1.3 Monitor Registration Detailed Protocol

Monitor registration request is made to designate the type of data that requires continuous monitoring and periodic updating.

#### Monitor Registration Request

Registration requests for  $n$  addresses (where  $n$  refers to the number of addresses. The addresses do not have to be contiguous.)

| ENQ    | Station ID | CMD    | Number of Addresses | Address     | SUM     | EOT    |
|--------|------------|--------|---------------------|-------------|---------|--------|
| 05h    | '01'-'1F'  | 'X'    | '1'-'8'=n           | 'XXXX...'   | 'XX'    | 04h    |
| 1 byte | 2 bytes    | 1 byte | 1 byte              | n x 4 bytes | 2 bytes | 1 byte |

Total bytes= (8 + n x 4): a maximum of 40

#### Monitor Registration Normal Response

| ACK    | Station ID | CMD    | SUM     | EOT    |
|--------|------------|--------|---------|--------|
| 06h    | '01'-'1F'  | 'X'    | 'XX'    | 04h    |
| 1 byte | 2 bytes    | 1 byte | 2 bytes | 1 byte |

Total bytes=7

#### Monitor Registration Error Response

| NAK    | Station ID | CMD    | Error Code | SUM     | EOT    |
|--------|------------|--------|------------|---------|--------|
| 15h    | '01'-'1F'  | 'X'    | '**'       | 'XX'    | 04h    |
| 1 byte | 2 bytes    | 1 byte | 2 bytes    | 2 bytes | 1 byte |

Total bytes=9

### 11.13.1.4 Monitor Execution Detailed Protocol

#### Monitor Registration Execution Request

A data read request for a registered address, received from a monitor registration request

| ENQ | Station ID | CMD | SUM  | EOT |
|-----|------------|-----|------|-----|
| 05h | '01'-'1F'  | 'Y' | 'XX' | 04h |

| ENQ    | Station ID | CMD    | SUM     | EOT    |
|--------|------------|--------|---------|--------|
| 1 byte | 2 bytes    | 1 byte | 2 bytes | 1 byte |

Total bytes=7

### Monitor Registration Execution Normal Response

| ACK    | Station ID | CMD    | Data        | SUM     | EOT    |
|--------|------------|--------|-------------|---------|--------|
| 06h    | '01'-'1F'  | 'Y'    | 'XXXX...'   | 'XX'    | 04h    |
| 1 byte | 2 bytes    | 1 byte | n x 4 bytes | 2 bytes | 1 byte |

Total bytes= (7 + n x 4): a maximum of 39

### Monitor Registration Execution Error Response

| NAK    | Station ID | CMD    | Error Code | SUM     | EOT    |
|--------|------------|--------|------------|---------|--------|
| 15h    | '01'-'1F'  | 'Y'    | ***        | 'XX'    | 04h    |
| 1 byte | 2 bytes    | 1 byte | 2 bytes    | 2 bytes | 1 byte |

Total bytes=9

### 11.13.15 Error Code

| Code                     | Abbreviation | Description   |
|--------------------------|--------------|---|
| 01: ILLEGAL FUNCTION     | IF           | The requested function cannot be performed by a slave because the corresponding function does not exist.                            |
| 02: ILLEGAL DATA ADDRESS | IA           | The received parameter address is invalid at the slave.   |
| 03: ILLEGAL DATA VALUE   | ID           | The received parameter data is invalid at the slave.  |
| 21: WRITE MODE ERROR     | WM           | Tried writing (W) to a parameter that does not allow writing (read-only parameters, or when writing is prohibited during operation) |
| 22: FRAME ERROR          | FE           | The frame size does not match.  |

## 11.13.2 Modbus-RTU protocol

### 11.13.2.1 Function Code and Protocol (unit: byte)

#### Function Code #03 (Read Holding Register)

##### <Query>

| Field Name          |
|---------------------|
| Slave Address       |
| Function            |
| Starting Address Hi |
| Starting Address Lo |
| # of Points Hi      |
| # of Points Lo      |
| CRC Lo              |
| CRC Hi              |
|                     |
|                     |
|                     |

##### <Response>

| Field Name               |
|--------------------------|
| Slave Address            |
| Function                 |
| Byte Count               |
| Data Hi (Register 40108) |
| Data Lo (Register 40108) |
| Data Hi (Register 40109) |
| Data Lo (Register 40109) |
| Data Hi (Register 40110) |
| Data Lo (Register 40110) |
| CRC Lo                   |
| CRC Hi                   |

#### Function Code #04 (Read Input Register)

##### <Query>

| Field Name          |
|---------------------|
| Slave Address       |
| Function            |
| Starting Address Hi |
| Starting Address Lo |
| # of Points Hi      |
| # of Points Lo      |
| CRC Lo              |
| CRC Hi              |

##### <Response>

| Field Name               |
|--------------------------|
| Slave Address            |
| Function                 |
| Byte Count               |
| Data Hi (Register 30009) |
| Data Lo (Register 30009) |
| CRC Lo                   |
| CRC Hi                   |

**Function Code #06 (Preset Single Register)**

**<Query>**

| Field Name          |
|---------------------|
| Slave Address       |
| Function            |
| Register Address Hi |
| Register Address Lo |
| Preset Data Hi      |
| Preset Data Lo      |
| CRC Lo              |
| CRC Hi              |

**<Response>**

| Field Name          |
|---------------------|
| Slave Address       |
| Function            |
| Register Address Hi |
| Register Address Lo |
| Preset Data Hi      |
| Preset Data Lo      |
| CRC Lo              |
| CRC Hi              |

**Function Code #16 (hex 0x10) (Preset Multiple Register)**

**<Query>**

| Field Name          |
|---------------------|
| Slave Address       |
| Function            |
| Starting Address Hi |
| Starting Address Lo |
| # of Register Hi    |
| # of Register Lo    |
| Byte Count          |
| Data Hi             |
| Data Lo             |
| Data Hi             |
| Data Lo             |
| CRC Lo              |
| CRC Hi              |

**<Response>**

| Field Name          |
|---------------------|
| Slave Address       |
| Function            |
| Starting Address Hi |
| Starting Address Lo |
| # of Register Hi    |
| # of Register Lo    |
| CRC Lo              |
| CRC Hi              |
|                     |
|                     |
|                     |
|                     |
|                     |
|                     |

**<Exception Code>**

| Code                   |
|------------------------|
| 01:ILLEGAL FUNCTION    |
| 02:ILLEGAL DATAADDRESS |
| 03: ILLEGAL DATA VALUE |
| 06: SLAVE DEVICE BUSY  |

**<Response>**

| Field Name    |
|---------------|
| Slave Address |



| Field Name     |
|----------------|
| Function*      |
| Exception Code |
| CRC Lo         |
| CRC Hi         |

\* Function value is the set value of the highest bit of the query function value.

### 11.13.3 iS7/iS5/iG5/iG5A Compatible Common Area Parameter

| Address | Parameter   | Scale | nit | R/W | Assigned content by bit   |
|---------|---|-------|-----|-----|---|
| 0h0000  | Inverter model  | -     | -   | R   | B: iS7  |
| 0h0001  | Inverter capacity   | -     | -   | R   | 0: 0.75 kW    1: 1.5 kW    2: 2.2 kW  |
|         |   |       |     |     | 3: 3.7 kW    4: 5.5 kW    5: 7.5 kW   |
|         |   |       |     |     | 6: 11 kW    7: 15 kW    8: 18.5 kW  |
|         |   |       |     |     | 9: 22 kW    10: 30 kW    11: 37 kW  |
|         |   |       |     |     | 12: 45 kW    13: 55 kW    14: 75 kW   |
|         |   |       |     |     | 15: 90 kW    16: 110 kW    17: 132 kW   |
|         |   |       |     |     | 18: 160 kW    19: 200 kW    20: 220 kW  |
|         |   |       |     |     | 21: 280 kW    22: 375 kW    65535: 0.4 kW   |
| 0h0002  | Inverter input voltage  | -     | -   | R   | 0: 220 V class<br>1: 400 V class  |
| 0h0003  | Version   | -     | -   | R   | Ex.) 0x0100: Version 1.00<br>0x0101: Version 1.01   |
| 0h0004  | Reserved  | -     | -   | R/W | -   |
| 0h0005  | Command frequency   | 0.01  | Hz  | R/W | -   |
| 0h0006  | Operating command (option)<br>* Refer to additional description | -     | -   | R   | B15   Reserved  |
|         |   |       |     |     | B14   0: Keypad Freq    1: Keypad Torq  |
|         |   |       |     |     | B13   2-16: Terminal block Multi-step speed   |
|         |   |       |     |     | B12   17: Up    18: Down    19: STEADY  |
|         |   |       |     |     | B11   20: AUTO-A    21: AUTO-B    22: V1  |
|         |   |       |     |     | B10   23: I1    24: V2    25: I2  |
|         |   |       |     |     | B9   26: Reserved    27: Built-in485  |
|         |   |       |     |     | B8   28: Communication option   |
|         |   |       |     |     | B7   29: PLC option    30: JOG    31: PID   |
|         |   |       |     |     | B6   0: Keypad    1: FX/RX-1    2: FX/RX-2<br>3: Built-in 485    4: Communication option<br>5: PLC option |

| Address | Parameter              | Scale | nit | R/W | Assigned content by bit |  |
|---------|------------------------|-------|-----|-----|-------------------------|--|
|         |                        |       |     | R/W | B5                      | Reserved   |
|         |                        |       |     |     | B4                      | Emergency stop   |
|         |                        |       |     |     | B3                      | W: Trip reset (0 ->1) R: Trip status   |
|         |                        |       |     |     | B2                      | Reverse operation (R)  |
|         |                        |       |     |     | B1                      | Forward operation (F)  |
|         |                        |       |     |     | B0                      | Stop (S)   |
| 0h0007  | Acceleration time      | 0.1   | sec | R/W | -                       |  |
| 0h0008  | Deceleration time      | 0.1   | sec | R/W | -                       |  |
| 0h0009  | Output current         | 0.1   | A   | R   | -                       |  |
| 0h000A  | Output frequency       | 0.01  | Hz  | R   | -                       |  |
| 0h000B  | Output voltage         | 1     | V   | R   | -                       |  |
| 0h000C  | DC Link voltage        | 1     | V   | R   | -                       |  |
| 0h000D  | Output power           | 0.1   | kW  | R   | -                       |  |
| 0h000E  | Operation status       | -     | -   | -   | B15                     | 0: Remote, 1: Keypad Local   |
|         |                        |       |     |     | B14                     | 1: Frequency command by comm. (Built-in type, Option)                        |
|         |                        |       |     |     | B13                     | 1: Run command by comm. (Built-in type, Option)                              |
|         |                        |       |     |     | B12                     | Reverse direction run command  |
|         |                        |       |     |     | B11                     | Forward direction run command  |
|         |                        |       |     |     | B10                     | Brake open signal  |
|         |                        |       |     |     | B9                      | Jog mode   |
|         |                        |       |     |     | B8                      | Stopping   |
|         |                        |       |     |     | B7                      | DC Braking   |
|         |                        |       |     |     | B6                      | Speed reached  |
|         |                        |       |     |     | B5                      | Decelerating   |
|         |                        |       |     |     | B4                      | Accelerating   |
|         |                        |       |     |     | B3                      | Operates depending on the set value of Fault (Trip)<br>*OUT-30 Trip Out Mode |
|         |                        |       |     |     | B2                      | Reverse operation  |
| B1      | Forward operation      |       |     |     |                         |  |
| B0      | Stopped                |       |     |     |                         |  |
| 0h000F  | Fault trip information | -     | -   | R   | B15                     | Reserved   |
|         |                        |       |     |     | B14                     | Reserved   |
|         |                        |       |     |     | B13                     | Reserved   |
|         |                        |       |     |     | B12                     | Reserved   |
|         |                        |       |     |     | B11                     | Reserved   |

## Communication Function

| Address | Parameter                   | Scale | nit | R/W | Assigned content by bit |                     |
|---------|-----------------------------|-------|-----|-----|-------------------------|---------------------|
|         |                             |       |     |     | B10                     | H/W-Diag            |
|         |                             |       |     |     | B9                      | Reserved            |
|         |                             |       |     |     | B8                      | Reserved            |
|         |                             |       |     |     | B7                      | Reserved            |
|         |                             |       |     |     | B6                      | Reserved            |
|         |                             |       |     |     | B5                      | Reserved            |
|         |                             |       |     |     | B4                      | Reserved            |
|         |                             |       |     |     | B3                      | Level Type Trip     |
|         |                             |       |     |     | B2                      | Reserved            |
|         |                             |       |     |     | B1                      | Reserved            |
| 0h0010  | Input terminal information  | -     | -   | R   | B0                      | Latch Type Trip     |
|         |                             |       |     |     | B1                      | Reserved            |
|         |                             |       |     |     | B2                      | Reserved            |
|         |                             |       |     |     | B3                      | Reserved            |
|         |                             |       |     |     | B4                      | Reserved            |
|         |                             |       |     |     | B5                      | Reserved            |
|         |                             |       |     |     | B6                      | Reserved            |
|         |                             |       |     |     | B7                      | Reserved            |
|         |                             |       |     |     | B8                      | P9 (I/O expansion)  |
|         |                             |       |     |     | B9                      | P10 (I/O expansion) |
|         |                             |       |     |     | B10                     | P11 (I/O expansion) |
|         |                             |       |     |     | B11                     | Reserved            |
|         |                             |       |     |     | B12                     | Reserved            |
|         |                             |       |     |     | B13                     | Reserved            |
| B14     | Reserved                    |       |     |     |                         |                     |
| 0h0011  | Output terminal information | -     | -   | R   | B15                     | Reserved            |
|         |                             |       |     |     | B14                     | Reserved            |
|         |                             |       |     |     | B13                     | Reserved            |
|         |                             |       |     |     | B12                     | Reserved            |
|         |                             |       |     |     | B11                     | Reserved            |
|         |                             |       |     |     | B10                     | Reserved            |
|         |                             |       |     |     | B9                      | Reserved            |
|         |                             |       |     |     | B8                      | Reserved            |
|         |                             |       |     |     | B7                      | Reserved            |

| Address           | Parameter             | Scale | nit | R/W | Assigned content by bit                |
|-------------------|-----------------------|-------|-----|-----|--|
|                   |                       |       |     |     | B6   Reserved                          |
|                   |                       |       |     |     | B5   Relay 5 (I/O expansion)           |
|                   |                       |       |     |     | B4   Relay 4 (I/O expansion)           |
|                   |                       |       |     |     | B3   Relay 3(I/O expansion)            |
|                   |                       |       |     |     | B2   Q1                                |
|                   |                       |       |     |     | B1   Relay 2                           |
|                   |                       |       |     |     | B0   Relay 1                           |
| 0h0012            | V1                    | 0.01  | %   | R   | V1 voltage input                       |
| 0h0013            | V2                    | 0.01  | %   | R   | V2 voltage input (expansion I/O)       |
| 0h0014            | I1                    | 0.01  | %   | R   | I1 current input                       |
| 0h0015            | Motor rotation speed  | 1     | rpm | R   | Current motor rotation speed displayed |
| 0h0016<br>-0h0019 | Reserved              | -     | -   | -   | -                                      |
| 0h001A            | Hz/rpm selection      | -     | -   | R   | 0: Hz unit<br>1: rpm unit              |
| 0h001B            | Motor poles displayed | -     | -   | R   | Motor poles displayed                  |

### 11.13.4 Expansion Common Area Parameter

#### 11.13.4.1 Inverter Monitoring Area Parameter (Read only)

| Address | Parameter   | Scale | unit | Assigned content by bit  |
|---------|---|-------|------|--|
| 0h0300  | Inverter model  | -     | -    | iS7: 000Bh   |
| 0h0301  | Inverter capacity   | -     | -    | 0.75 kW: 3200h<br>1.5 kW: 4015h, 2.2 kW: 4022h, 3.7kW: 4037h,<br>5.5 kW: 4055h, 7.5 kW: 4075h, 11 kW: 40B0h<br>15 kW: 40F0h, 18.5 kW: 4125h, 22 kW: 4160h,<br>30 kW: 41E0h, 37 kW: 4250h, 45 kW: 42D0h<br>55 kW: 4370h, 75 kW: 44B0h, 90 kW: 45A0h<br>110 kW: 46E0h, 132 kW: 4840h, 160 kW: 4A00h<br>185 kW: 4B90h                         |
| 0h0302  | Inverter input voltage / power supply type (single phase, 3 phase) / cooling method | -     | -    | 200 V single phase open air cooling: 0220h<br>200 V 3 phase open air cooling: 0230h<br>200 V single phase forced cooling: 0221h<br>200 V 3 phase forced cooling: 0231h<br>400 V single open air cooling: 0420h<br>400 V 3 phase open air cooling: 0430h<br>400 V single phase forced cooling: 0421h<br>400 V 3 phase forced cooling: 0431h |
| 0h0303  | Inverter S/W version  | -     | -    | Ex.) 0x0100: Version 1.00<br>0x0101: Version 1.01  |
| 0h0304  | Reserved  | -     | -    | -  |
| 0h0305  | Inverter operating status   | -     | -    | B15<br>B14<br>B13<br>B12<br>B11<br>B10<br>B9<br>B8<br>0000(0) : Normal status<br>0100(4): Warning status<br>1000(8): Fault status (operates according to set value of OUT-30 Trip Out Mode)  |

| Address        | Parameter   | Scale | unit | Assigned content by bit   |   |
|----------------|---|-------|------|---------------------------|---|
|                |   |       |      | B7                        | 0001(1): Speed search<br>0010(2): Accelerating  |
|                |   |       |      | B6                        | 0011(3): Steady speed<br>0100(4): Decelerating  |
|                |   |       |      | B5                        | 0101(5): Decelerating stop<br>0110(6): HW OCS   |
|                |   |       |      | B4                        | 0111(7): SW OCS<br>1000(8): Dwell operating   |
|                |   |       |      | B3                        | 0000(0): Stop<br>0001(1): Forward operating<br>0010(2): Reverse operating<br>0011(3): DC operating (0 speed control)  |
|                |   |       |      | B2                        |   |
|                |   |       |      | B1                        |   |
|                |   |       |      | B0                        |   |
| 0h0306         | Inverter run frequency command source   | -     | -    | B15                       | Run command source<br>00000000(0):Keypad<br>00000001(1):Communication option<br>00000010(2):App/PLC<br>00000011(3):Built-in 485<br>00000100(4):Terminal Block<br>00000101(5):reserved<br>00000110(6):Auto 1<br>00000111(7):Auto 2 |
|                |   |       |      | B14                       |   |
|                |   |       |      | B13                       |   |
|                |   |       |      | B12                       |   |
|                |   |       |      | B11                       |   |
|                |   |       |      | B10                       |   |
|                |   |       |      | B9                        |   |
|                |   |       |      | B8                        |   |
|                |   |       |      | B7                        | Frequency command source  |
|                |   |       |      | B6                        | 00000000(0):Keypad speed<br>00000001(1):Keypad torque   |
|                |   |       |      | B5                        | 00000010~00000100(2~4):Up/Down run speed  |
|                |   |       |      | B4                        | 00000101(5): V1    00000110(6): I1  |
|                |   |       |      | B3                        | 00000111(7): V2    00001000(8): I2  |
|                |   |       |      | B2                        | 00001001(9): Pulse  |
|                |   |       |      | B1                        | 00001010(10):Bulit-in 485<br>00001011(11):Comm option<br>00001100(12): App(PLC)   |
| B0             | 00001101(13): Jog    00001110(14): PID<br>00001111~00101110(15~22) : Auto Step<br>00011001~00100111(25~39) : Multi-step speed frequency |       |      |                           |   |
| 0h0307         | Keypad S/W version  | -     | -    | Ex.) 0x0100: Version 1.00 |   |
| 0h0308         | Keypad Title version  | -     | -    | 0x0101: Version 1.01      |   |
| 0h0309 - 0h30F | Reserved  | -     | -    | -                         |   |

## Communication Function

| Address           | Parameter                        | Scale | unit | Assigned content by bit                             |                     |
|-------------------|----------------------------------|-------|------|---|---------------------|
| 0h0310            | Output current                   | 0.1   | A    | -   |                     |
| 0h0311            | Output frequency                 | 0.01  | Hz   | -   |                     |
| 0h0312            | Output RPM                       | 0     | RPM  | -   |                     |
| 0h0313            | Motor feedback speed             | 0     | RPM  | -32768rpm - 32767rpm (Having a polarity.)           |                     |
| 0h0314            | Output voltage                   | 1     | V    | -   |                     |
| 0h0315            | DC Link voltage                  | 1     | V    | -   |                     |
| 0h0316            | Output power                     | 0.1   | kW   | -   |                     |
| 0h0317            | Output torque                    | 0.1   | %    | Exception: It is not calculated during V/F control. |                     |
| 0h0318            | PID reference                    | 0.1   | %    | -   |                     |
| 0h0319            | PID feedback                     | 0.1   | %    | -   |                     |
| 0h031A            | Number of No.1 motor display     | -     | -    | Number of No.1 motor display                        |                     |
| 0h031B            | Number of No.2 motor display     | -     | -    | Number of No.2 motor display                        |                     |
| 0h031C            | Number of selected motor display | -     | -    | Number of selected motor display                    |                     |
| 0h031D            | Selection among Hz/rpm           | -     | -    | 0: Hz unit<br>1: rpm unit                           |                     |
| 0h031E<br>-0h031F | Reserved                         | -     | -    | -   |                     |
| 0h0320            | Digital input information        | -     | -    | B15   | Reserved            |
|                   |                                  |       |      | B14   | Reserved            |
|                   |                                  |       |      | B13   | Reserved            |
|                   |                                  |       |      | B12   | Reserved            |
|                   |                                  |       |      | B11   | Reserved            |
|                   |                                  |       |      | B10   | P11 (I/O expansion) |
|                   |                                  |       |      | B9  | P10 (I/O expansion) |
|                   |                                  |       |      | B8  | P9 (I/O expansion)  |
|                   |                                  |       |      | B7  | P8 (Basic I/O)      |
|                   |                                  |       |      | B6  | P7 (Basic I/O)      |
|                   |                                  |       |      | B5  | P6 (Basic I/O)      |
| B4                | P5 (Basic I/O)                   |       |      |   |                     |
| B3                | P4 (Basic I/O)                   |       |      |   |                     |

| Address | Parameter                         | Scale | unit | Assigned content by bit |                         |
|---------|-----------------------------------|-------|------|-------------------------|-------------------------|
|         |                                   |       |      | Bit                     | Content                 |
|         |                                   |       |      | B2                      | P3 (Basic I/O)          |
|         |                                   |       |      | B1                      | P2 (Basic I/O)          |
|         |                                   |       |      | B0                      | P1 (Basic I/O)          |
| 0h0321  | Digital output information        | -     | -    | B15                     | Reserved                |
|         |                                   |       |      | B14                     | Reserved                |
|         |                                   |       |      | B13                     | Reserved                |
|         |                                   |       |      | B12                     | Reserved                |
|         |                                   |       |      | B11                     | Reserved                |
|         |                                   |       |      | B10                     | Reserved                |
|         |                                   |       |      | B9                      | Reserved                |
|         |                                   |       |      | B8                      | Reserved                |
|         |                                   |       |      | B7                      | Reserved                |
|         |                                   |       |      | B6                      | Reserved                |
|         |                                   |       |      | B5                      | Relay 5 (I/O expansion) |
|         |                                   |       |      | B4                      | Relay 4 (I/O expansion) |
|         |                                   |       |      | B3                      | Relay 3 (I/O expansion) |
|         |                                   |       |      | B2                      | Q1 (Basic I/O)          |
|         |                                   |       |      | B1                      | Relay 2 (Basic I/O)     |
| B0      | Relay 1 (Basic I/O)               |       |      |                         |                         |
| 0h0322  | Virtual digital input information | -     | -    | B15                     | Virtual DI 16 (COM85)   |
|         |                                   |       |      | B14                     | Virtual DI 15 (COM84)   |
|         |                                   |       |      | B13                     | Virtual DI 14 (COM83)   |
|         |                                   |       |      | B12                     | Virtual DI 13 (COM82)   |
|         |                                   |       |      | B11                     | Virtual DI 12 (COM81)   |
|         |                                   |       |      | B10                     | Virtual DI 11 (COM80)   |
|         |                                   |       |      | B9                      | Virtual DI 10 (COM79)   |
|         |                                   |       |      | B8                      | Virtual DI 9 (COM78)    |
|         |                                   |       |      | B7                      | Virtual DI 8 (COM77)    |
|         |                                   |       |      | B6                      | Virtual DI 7 (COM76)    |



## Communication Function

| Address | Parameter                              | Scale | unit | Assigned content by bit        |                       |
|---------|--|-------|------|--------------------------------|-----------------------|
|         |  |       |      | Bit                            | Content               |
|         |  |       |      | B5                             | Virtual DI 6 (COM75)  |
|         |  |       |      | B4                             | Virtual DI 5 (COM74)  |
|         |  |       |      | B3                             | Virtual DI 4 (COM73)  |
|         |  |       |      | B2                             | Virtual DI 3 (COM72)  |
|         |  |       |      | B1                             | Virtual DI 2 (COM71)  |
|         |  |       |      | B0                             | Virtual DI 1 (COM70)  |
| 0h0323  | Selected motor display                 | -     | -    | 0: No.1 motor / 1: No.2 motor  |                       |
| 0h0324  | AI1                                    | 0.01  | %    | Analog input1 (Basic I/O)      |                       |
| 0h0325  | AI2                                    | 0.01  | %    | Analog input2 (Basic I/O)      |                       |
| 0h0326  | AI3                                    | 0.01  | %    | Analog input3 (I/O expansion)  |                       |
| 0h0327  | AI4                                    | 0.01  | %    | Analog input4 (I/O expansion)  |                       |
| 0h0328  | AO1                                    | 0.01  | %    | Analog output1 (Basic I/O)     |                       |
| 0h0329  | AO2                                    | 0.01  | %    | Analog output2 (Basic I/O)     |                       |
| 0h032A  | AO3                                    | 0.01  | %    | Analog output3 (I/O expansion) |                       |
| 0h032B  | AO4                                    | 0.01  | %    | Analog output4 (I/O expansion) |                       |
| 0h032C  | Reserved                               | -     | -    | -                              |                       |
| 0h032D  | Temperature                            | 1     | °C   | -                              |                       |
| 0h032E  | Power consumption of inverter(kW/hour) | 0.1   | kWh  | -                              |                       |
| 0h032F  | Power consumption of inverter(MW/hour) | 1     | MWh  | -                              |                       |
| 0h0330  | Latch type trip information-1          |       |      | B15                            | Fuse Open Trip        |
|         |  |       |      | B14                            | Overheat Trip         |
|         |  |       |      | B13                            | Arm Short             |
|         |  |       |      | B12                            | External Trip         |
|         |  |       |      | B11                            | Overvoltage Trip      |
|         |  |       |      | B10                            | Overcurrent Trip      |
|         |  |       |      | B9                             | NTC Trip              |
|         |  |       |      | B8                             | Overspeed Deviation   |
|         |  |       |      | B7                             | Overspeed             |
|         |  |       |      | B6                             | Input open-phase trip |

| Address | Parameter                     | Scale | unit | Assigned content by bit |  |
|---------|-------------------------------|-------|------|-------------------------|--|
|         |                               |       |      | B5                      | Output open-phase trip   |
|         |                               |       |      | B4                      | Ground Fault Trip  |
|         |                               |       |      | B3                      | E-Thermal Trip   |
|         |                               |       |      | B2                      | Inverter Overload Trip   |
|         |                               |       |      | B1                      | Underload Trip   |
|         |                               |       |      | B0                      | Overload Trip  |
| 0h0331  | Latch type trip information-2 | -     | -    | B15                     | Low Voltage2   |
|         |                               |       |      | B14                     | Reserved   |
|         |                               |       |      | B13                     | Inverter output cutoff by terminal block input on Safety Option (applied to above 90 kW) |
|         |                               |       |      | B12                     | Slot3 option board contact defectiveness   |
|         |                               |       |      | B11                     | Slot2 option board contact defectiveness   |
|         |                               |       |      | B10                     | Slot1 option board contact defectiveness   |
|         |                               |       |      | B9                      | No MotorTrip   |
|         |                               |       |      | B8                      | External Brake Trip  |
|         |                               |       |      | B7                      | Basic IO board contact defectiveness   |
|         |                               |       |      | B6                      | Pre PID Fail   |
|         |                               |       |      | B5                      | Error on Parameter Write   |
|         |                               |       |      | B4                      | Reserved   |
|         |                               |       |      | B3                      | FAN Trip   |
|         |                               |       |      | B2                      | PTC (Thermal sensor) Trip  |
| B1      | Encoder Error Trip            |       |      |                         |  |
| B0      | MC Fail Trip                  |       |      |                         |  |
| 0h0332  | Level type trip information   | -     | -    | B15                     | Reserved   |
|         |                               |       |      | B14                     | Reserved   |
|         |                               |       |      | B13                     | Reserved   |
|         |                               |       |      | B12                     | Reserved   |
|         |                               |       |      | B11                     | Reserved   |
|         |                               |       |      | B10                     | Reserved   |
|         |                               |       |      | B9                      | Reserved   |

## Communication Function

| Address | Parameter                      | Scale | unit | Assigned content by bit |                       |
|---------|--------------------------------|-------|------|-------------------------|-----------------------|
|         |                                |       |      | B8                      | Reserved              |
|         |                                |       |      | B7                      | Reserved              |
|         |                                |       |      | B6                      | Reserved              |
|         |                                |       |      | B5                      | Reserved              |
|         |                                |       |      | B4                      | Reserved              |
|         |                                |       |      | B3                      | Keypad Lost Command   |
|         |                                |       |      | B2                      | Lost Command          |
|         |                                |       |      | B1                      | LV                    |
|         |                                |       |      | B0                      | BX                    |
| 0h0333  | H/W Diagnosis Trip information | -     | -    | B15                     | Reserved              |
|         |                                |       |      | B14                     | Reserved              |
|         |                                |       |      | B13                     | Reserved              |
|         |                                |       |      | B12                     | Reserved              |
|         |                                |       |      | B11                     | Reserved              |
|         |                                |       |      | B10                     | Reserved              |
|         |                                |       |      | B9                      | Reserved              |
|         |                                |       |      | B8                      | Reserved              |
|         |                                |       |      | B7                      | Reserved              |
|         |                                |       |      | B6                      | Reserved              |
|         |                                |       |      | B5                      | Reserved              |
|         |                                |       |      | B4                      | Gate Drive Power Loss |
|         |                                |       |      | B3                      | Watchdog-2 error      |
|         |                                |       |      | B2                      | Watchdog-1 error      |
|         |                                |       |      | B1                      | EEPROM error          |
|         |                                |       |      | B0                      | ADC error             |
| 0h0334  | Warning information            | -     | -    | B15                     | Reserved              |
|         |                                |       |      | B14                     | Reserved              |
|         |                                |       |      | B13                     | Reserved              |
|         |                                |       |      | B12                     | Reserved              |

| Address           | Parameter       | Scale | unit | Assigned content by bit                                  |  |
|-------------------|-----------------|-------|------|--|--|
|                   |                 |       |      | B11  | Reserved                                     |
|                   |                 |       |      | B10  | Fire function operation                      |
|                   |                 |       |      | B9   | Auto Tuning fail                             |
|                   |                 |       |      | B8   | Keypad Lost                                  |
|                   |                 |       |      | B7   | Encoder mis-wiring                           |
|                   |                 |       |      | B6   | Encoder mis-installation                     |
|                   |                 |       |      | B5   | DB   |
|                   |                 |       |      | B4   | FAN operation                                |
|                   |                 |       |      | B3   | Lost command                                 |
|                   |                 |       |      | B2   | Inverter Overload                            |
|                   |                 |       |      | B1   | Underload                                    |
|                   |                 |       |      | B0   | Overload                                     |
| 0h0335–<br>0h033F | Reserved        | -     | -    | -  | -  |
| 0h0340            | On Time date    | 0     | Day  | Date of inverter power On                                |  |
| 0h0341            | On Time minute  | 0     | Min  | Total minute, except for total date, of inverter On Time |  |
| 0h0342            | Run Time date   | 0     | Day  | Total number of days of inverter run                     |  |
| 0h0343            | Run Time minute | 0     | Min  | Total minute, except for total day, of Run Time          |  |
| 0h0344            | Fan Time date   | 0     | Day  | Total days of cooling fan run                            |  |
| 0h0345            | Fan Time minute | 0     | Min  | Total minute except for total day of Fan time            |  |
| 0h0346            | Reserved        | -     | -    | -  | -  |
| 0h0347            | Reserved        | -     | -    | -  | -  |
| 0h0348            | Reserved        | -     | -    | -  | -  |
| 0h0349            | Reserved        | -     | -    | -  | -  |
| 0h034A            | Option 1        | -     | -    | 0: None<br>2: Reserved<br>4: Reserved                    | 1: Reserved<br>3: Profibus,<br>5: Reserved   |
| 0h034B            | Option 2        | -     | -    | 6: Reserved<br>8: Reserved<br>10: PLC                    | 7: RNet,<br>9: Reserved<br>20: External IO-1 |
| 0h034C            | Option 3        |       |      | 23: Encoder  |  |

11.13.4.2 Inverter Control Area Parameter (Reading and Writing Available)

| Address                         | Parameter                                   | Scale | unit | Bit allotment   |  |
|---------------------------------|---|-------|------|---|--|
| 0h0380<br><small>note1)</small> | Frequency command                           | 0.01  | Hz   | Command frequency setting   |  |
| 0h0381                          | RPM command                                 | 1     | rpm  | command RPM setting   |  |
| 0h0382                          | Operating command                           | -     | -    | B7  | Reserved                                 |
|                                 |   |       |      | B6  | Reserved                                 |
|                                 |   |       |      | B5  | Reserved                                 |
|                                 |   |       |      | B4  | Reserved                                 |
|                                 |   |       |      | B3  | 0→1: Free run stop                       |
|                                 |   |       |      | B2  | 0→1: Trip reset                          |
|                                 |   |       |      | B1  | 0:Reverse command      1:Forward command |
|                                 |   |       |      | B0  | 0:Stop command          1:Run command    |
|                                 |   |       |      | Ex) Forward operating command: 0003h,<br>Reverse operating command: 0001h |  |
|                                 |   |       |      | 0h0383  | Accelerating time                        |
| 0h0384                          | Decelerating time                           | 0.1   | sec  | Decelerating time setting   |  |
| 0h0385                          | Virtual digital input control (0:Off, 1:On) | -     | -    | B15   | Virtual DI 16 (COM85)                    |
|                                 |   |       |      | B14   | Virtual DI 15 (COM84)                    |
|                                 |   |       |      | B13   | Virtual DI 14 (COM83)                    |
|                                 |   |       |      | B12   | Virtual DI 13 (COM82)                    |
|                                 |   |       |      | B11   | Virtual DI 12 (COM81)                    |
|                                 |   |       |      | B10   | Virtual DI 11 (COM80)                    |
|                                 |   |       |      | B9  | Virtual DI 10 (COM79)                    |
|                                 |   |       |      | B8  | Virtual DI 9 (COM78)                     |
|                                 |   |       |      | B7  | Virtual DI 8 (COM77)                     |
|                                 |   |       |      | B6  | Virtual DI 7 (COM76)                     |
|                                 |   |       |      | B5  | Virtual DI 6 (COM75)                     |
|                                 |   |       |      | B4  | Virtual DI 5 (COM74)                     |
|                                 |   |       |      | B3  | Virtual DI 4 (COM73)                     |
|                                 |   |       |      | B2  | Virtual DI 3 (COM72)                     |
| B1                              | Virtual DI 2 (COM71)                        |       |      |   |  |

| Address                           | Parameter                               | Scale | unit | Bit allotment                     |
|-----------------------------------|---|-------|------|-----------------------------------|
|                                   |   |       |      | B0 Virtual DI 1 (COM70)           |
| 0h0386                            | Digital output control<br>(0:Off, 1:On) | -     | -    | B15 Reserved                      |
|                                   |   |       |      | B14 Reserved                      |
|                                   |   |       |      | B13 Reserved                      |
|                                   |   |       |      | B12 Reserved                      |
|                                   |   |       |      | B11 Reserved                      |
|                                   |   |       |      | B10 Reserved                      |
|                                   |   |       |      | B9 Reserved                       |
|                                   |   |       |      | B8 Reserved                       |
|                                   |   |       |      | B7 Reserved                       |
|                                   |   |       |      | B6 Reserved                       |
|                                   |   |       |      | B5 Q4 (I/O expansion, OUT36:None) |
|                                   |   |       |      | B4 Q3 (I/O expansion, OUT35:None) |
|                                   |   |       |      | B3 Q2 (I/O expansion, OUT34:None) |
|                                   |   |       |      | B2 Q1 (basic I/O, OUT33:None)     |
| B1 Relay2 (basic I/O, OUT32:None) |   |       |      |                                   |
| B0 Relay1 (basic I/O, OUT31:None) |   |       |      |                                   |
| 0h0387                            | Reserved                                | -     | -    | Reserved                          |
| 0h0388                            | PID reference                           | 0.1   | %    | PID reference command released    |
| 0h0389                            | PID feedback value                      | 0.1   | %    | PID feedback value                |
| 0h038A<br>-0h038F                 | Reserved                                | -     | -    | -                                 |
| 0h0390                            | Torque Ref                              | 0.1   | %    | Torque command                    |
| 0h0391                            | Fwd Pos Torque Limit                    | 0.1   | %    | Forward motor ring torque limit   |
| 0h0392                            | Fwd Neg Torque Limit                    | 0.1   | %    | Forward regenerative torque limit |
| 0h0393                            | Rev Pos Torque Limit                    | 0.1   | %    | Reverse motor ring torque limit   |
| 0h0394                            | Rev Neg Torque Limit                    | 0.1   | %    | Reverse regenerative torque limit |
| 0h0395                            | Torque Bias                             | 0.1   | %    | Torque Bias                       |
| 0h0395                            | Reserved                                | -     | -    | -                                 |

| Address | Parameter      | Scale | unit | Bit allotment        |
|---------|----------------|-------|------|----------------------|
| -0h399  |                |       |      |                      |
| 0h039A  | Anytime Para   | -     | -    | CNF-20 value setting |
| 0h039B  | Monitor Line-1 | -     | -    | CNF-21 value setting |
| 0h039C  | Monitor Line-2 | -     | -    | CNF-22 value setting |
| 0h039D  | Monitor Line-3 | -     | -    | CNF-23 value setting |

- Note1) A frequency set via communication using the iS7 common area frequency address (0h0380, 0h0005) is not saved even when used with the parameter save function. To save a changed frequency to use after a power cycle, follow these steps:
  - Set DRV-07 to Keypad-1 and select a random target frequency.
  - Cmd Frequency (DRV-01, 0h1101): Set the frequency via communication into the parameter area frequency address (0h1101).
  - Parameter Save (0h03E0): Set to "1" before turning off the power.
  - The frequency set via communication will be displayed after turning the power off and on again.

### 11.13.4.3 Inverter Memory Control Area Parameter (Reading and Writing Available)

When setting parameters in the inverter memory control area, the values are reflected to the inverter operation and saved. Parameters set in other areas via communication are reflected in the inverter operation, but are not saved.

All set values are cleared following an inverter power cycle and revert back to their previous values. When setting parameters via communication, ensure that a parameter is saved prior to turning off the inverter.

| Address                   | Parameter                                       | Scale | unit | Changeable During Operation | Function   | Page |
|---------------------------|---|-------|------|-----------------------------|--|------|
| 0h03E0 <sup>note1)</sup>  | Parameter saving                                | -     | -    | X                           | 0: No      1: Yes  | 256  |
| 0h03E1 <sup>note1)</sup>  | Monitor mode initialization                     | -     | -    | O                           | 0: No      1: Yes  | 257  |
| 0h03E2 <sup>note1)</sup>  | Parameter initialization                        | -     | -    | X                           | 0: No      1: All Grp<br>2: Drv Grp      3: BAS Grp<br>4: ADV Grp      5: CON Grp<br>6: IN Grp      7: OUT Grp<br>8: COM Grp      9: APP Grp<br>10: AUT Grp      11: APO Grp<br>12: PRT Grp      13: M2 Grp<br>*No setting during trip | 257  |
| 0h03E3                    | Display changed parameter                       | -     | -    | O                           | 0: No      1: Yes  | 260  |
| 0h03E4                    | Macro function item                             | -     | -    | X                           | 0: None<br>1: Draw App<br>2: Traverse  | 262  |
| 0h03E5 <sup>note1)</sup>  | Deleted all fault history                       | -     | -    | O                           | 0: No      1: Yes  | 260  |
| 0h03E6 <sup>note1)</sup>  | User registration code deleted                  | -     | -    | O                           | 0: No      1: Yes  | 260  |
| 0h03E7 <sup>note 2)</sup> | Hide parameter mode                             | 0     | Hex  | O                           | writing: 0 - 9999<br>reading: 0: Unlock      1: Lock   | 258  |
| 0h03E8 <sup>note 2)</sup> | Lock parameter mode                             | 0     | Hex  | O                           | writing: 0 - 9999<br>reading: 0: Unlock      1: Lock   | 259  |
| 0h03E9                    | Easy start on (easy parameter setup mode)       | -     | -    | O                           | 0: No      1: Yes  | 263  |
| 0h03EA <sup>note1)</sup>  | Initializing power consumption                  | -     | -    | O                           | 0: No      1: Yes  | 284  |
| 0h03EB <sup>note1)</sup>  | Initialize inverter operation accumulative time | -     | -    | O                           | 0: No      1: Yes  | 284  |
| 0h03EC <sup>note1)</sup>  | Initialize cooling                              | -     | -    | O                           | 0: No      1: Yes  | 264  |



| Address | Parameter                      | Scale | unit | Changeable During Operation | Function | Page |
|---------|--------------------------------|-------|------|-----------------------------|----------|------|
|         | fan accumulated operation time |       |      |                             |          |      |

Note 1

- Set parameters very carefully. After setting a parameter to "0" via communication, set it to another value. If a parameter has been set to a value other than 0 and a non-zero value is entered again, an error message is returned. The previously set value can be identified by reading the parameter when operating the inverter via communication.

Note that the execution time may take longer because the data is saved in the inverter, possibly interrupting communication.

Note 2

- The addresses 0h03E7 and 0h03E8 are parameters for entering the password. When the password is entered, the condition will change from "Lock" to "Unlock", and vice versa.

When the same parameter value is entered repeatedly, the parameter setting is executed just once. To enter the same value, change it to another value first and then re-enter the previous value. For example, if you want to enter 244 twice, enter it in the following order: 244 -> 0 -> 244.

# 12 Troubleshooting and Maintenance

This chapter explains how to troubleshoot a problem when inverter protective functions, fault trips, warning signals, or faults occur. If the inverter does not work normally after following the suggested troubleshooting steps, please contact the LS ELECTRIC Customer Support.

## Danger

Wait at least 10 minutes before opening the covers and exposing the terminal connections. Before working on the inverter, test the connections to ensure the DC voltage has been fully discharged. Personal injury or death by electric shock may result if the DC voltage has not been discharged.

## 12.1 Protection Functions

### 12.1.1 Protection from Output Current and Input Voltage

| Type                      | Category | Details   | Remarks |
|---------------------------|----------|---|---------|
| Over Load                 | Latch    | Displayed when the motor overload trip is activated and the actual load level exceeds the set level. Operates when PRT-20 is set to any value other than "0".                                     | -       |
| Under Load                | Latch    | Displayed when the motor underload trip is activated and the actual load level is less than the set level. Operates when PRT-27 is set to any value other than "0".                               | -       |
| Over Current <sup>1</sup> | Latch    | Displayed when the inverter output current exceeds 200% of the rated current.   | -       |
| Over Voltage              | Latch    | Displayed when the internal DC circuit voltage exceeds the specified value.   | -       |
| Low Voltage               | Level    | Displayed when the internal DC circuit voltage is less than the specified value.  | -       |
| Ground Trip               | Latch    | Displayed when a ground fault trip occurs on the output side of the inverter and causes the current to exceed the specified value. The specified value varies depending on the inverter capacity. | -       |
| E-Thermal                 | Latch    | Displayed based on inverse time limit thermal characteristics to prevent motor overheating. Operates when PRT-40 is set to any value other than "0".  | -       |
| Out Phase Open            | Latch    | Displayed when a 3-phase inverter output has one or more phases in an open circuit condition. Operates when bit 1 of PRT-05 is set to "1".  | -       |

| Type           | Category | Details  | Remarks |
|----------------|----------|--|---------|
| In Phase Open  | Latch    | Displayed when a 3-phase inverter input has one or more phases in an open circuit condition. Operates only when bit 2 of PRT-05 is set to "1".   | -       |
| Inverter OLT   | Latch    | Displayed when the inverter has been protected from overload and resultant overheating, based on inverse time limit thermal characteristics. Allowable overload rates for the inverter are 150% for 1 min and 200% for 4 sec. Protection is based on the inverter rated capacity, and may vary depending on the device's capacity. | -       |
| Low Voltage2   | Latch    | Displayed when the internal DC circuit voltage is less than the specified value during inverter operation.   | -       |
| Safety Opt Err | Latch    | Displayed when a safety feature is activated to block the inverter output during an emergency.   | -       |

### 12.1.2 Abnormal Circuit Conditions and External Signals

| Type          | Category | Details  | Remarks |
|---------------|----------|--|---------|
| Fuse Open     | Latch    | Displayed when the inverter DC fuse is exposed to an overcurrent above 30 kW.  | -       |
| Over Heat     | Latch    | Displayed when the temperature of the inverter heat sink exceeds the specified value.  | -       |
| Over Current2 | Latch    | Displayed when the DC circuit in the inverter detects a specified level of excessive, short circuit current.   | -       |
| External Trip | Latch    | Displayed when an external fault signal is provided by the multi-function terminal. Set one of the multi-function input terminals at IN-65-72 to "3 (External Trip)" to enable external trip.  | -       |
| BX            | Level    | Displayed when the inverter output is blocked by a signal provided from the multi-function terminal. Set one of the multi-function input terminals at IN-65-71 to "4 (BX)" to enable the input block function.   | -       |
| H/W-Diag      | Fatal    | <p>Displayed when an error is detected in the memory (EEPROM), analog-digital converter output (ADC Off Set), or CPU watchdog (Watch Dog-1, Watch Dog-2).</p> <p>EEP Err: An error in reading/writing parameters due to a keypad or memory (EEPROM) fault.</p> <p>ADC Off Set: An error in the current sensing circuit (U/V/W terminal, current sensor, etc.).</p> <p>Gate Pwr Loss: An interruption in the supply of power to the IGBT Gate of a product rated 30 kW or higher (when a fault occurs in a 22 kW-rated product, the capacity settings should be</p> | -       |

| Type            | Category | Details  | Remarks                      |
|-----------------|----------|--|------------------------------|
|                 |          | checked).  |                              |
| NTC Open        | Latch    | Displayed when an error is detected in the temperature sensor of the Insulated Gate Bipolar Transistor (IGBT).   | -                            |
| Fan Trip        | Latch    | Displayed when an error is detected in the cooling fan. Set PRT-79 to "0" to activate fan trip (for models with a capacity below 22 kW).   | -                            |
| IP54 FAN Trip   | Latch    | Displayed when the IP54 product detects an internal circulation at the cooling fan.  | Only applied to IP54 product |
| Thermal Trip    | Latch    | Displayed when the resistance value exceeds the prescribed value after the external temperature sensor is connected to the terminal block. Operates when PRT-34 is set to any value other than "0".  | -                            |
| ParaWrite Trip  | Latch    | Displayed when communication fails during parameter writing. Occurs when using an LCD keypad due to a control cable fault or a bad connection.   | -                            |
| Over Speed Trip | Latch    | Displayed when the motor speed exceeds the overspeed detection level. Set the detection level at PRT-70.   | -                            |
| Dev Speed Trip  | Latch    | Displayed when the speed that received feedback from the encoder exceeds the set variation value. Operates when PRT-73 is set to "1".  | -                            |
| Encoder Trip    | Latch    | Displayed when PRT-77 Enc Wire Check is set to "1" and an abnormality is detected for the set period of time.  | -                            |
| Pre-PID Fail    | Latch    | Displayed when pre-PID is operating with functions set at APP-34–36. A fault trip occurs when a controlled variable (PID feedback) is measured below the set value and the low feedback continues, as it is treated as a load fault.   | -                            |
| Ext-Brake       | Latch    | When Control Mode (DRV-09) is V/F or Sensorless1 or Sensorless2: The trip occurs when OUT-31–32 is set to BR control and the output current is lower than ADV-41 value (% for BAS-13) for about 10 seconds.<br><br>When Control Mode (DRV-09) is Vector: The trip occurs when OUT-31-32 is set to BR Control and the current is lower than half of the BAS-14 value. | -                            |

### 12.1.3 Keypad and Optional Expansion Modules

| Type           | Category | Details  | Remarks |
|----------------|----------|--|---------|
| Lost Keypad    | Level    | Displayed when operating commands come from the keypad or there is any problem with the communication between the keypad and inverter's main body in Keypad JOG mode. Operates when PRT-11 is set to any value other than "0" (occurs 2 seconds after the communication is interrupted). | -       |
| Lost Command   | Level    | Displayed when a frequency or operation command error is detected during inverter operation by controllers other than the keypad (e.g. using a terminal block and a communication mode). Set PRT-12 to any value other than "0".   | -       |
| Option Trip-1  | Latch    | Displayed when the extension module is removed from option slot No. 1 after it was installed while the inverter was turned on, or when communication is not available with the inverter.   | -       |
| Option Trip-2  | Latch    | Displayed when the extension module is removed from option slot No. 2 after it was installed during power supply, or when communication is not available with the inverter.  | -       |
| Option Trip-3  | Latch    | Displayed when the extension module is removed from option slot No. 3 after it was installed during power supply, or when communication is not available with the inverter.  | -       |
| I/O Board Trip | Latch    | Displayed when the basic and insulated I/O boards are disconnected or have a connection fault.   | -       |

#### Note

**Level:** When the fault is corrected, the trip or warning signal disappears and the fault is not saved in the fault history.

**Latch:** When the fault is corrected and a reset input signal is provided, the trip or warning signal disappears.

**Fatal:** When the fault is corrected, the fault trip or warning signal disappears only after the user turns off the inverter, waits until the charge indicator light goes off, and turns the inverter on again. If the inverter is still in a fault condition after it is powered on again, please contact the supplier or the LS ELECTRIC Customer Support.

The function for saving the fault history and the fault signal output may not be performed if the functions are not set or the inverter is seriously damaged.

## 12.2 Warning Messages

| Type           | Description  |
|----------------|--|
| Over Load      | Displayed when the motor is overloaded. Operates when PRT-17 is set to "1". To operate, select "4 (Over Load)". Set the digital output terminal or relay (OUT31-33) to "4 (Over Load)" to receive overload warning output signals.                                 |
| Under Load     | Displayed when the motor is underloaded. Operates when PRT-25 is set to "1". Set the digital output terminal or relay (OUT31-33) to "6 (Under Load)" to receive underload warning output signals.  |
| Inv Over Load  | Displayed when the accumulated overload time is equivalent to 60% of the inverter overheat protection (inverter IOLT) level. Set the digital output terminal or relay (OUT31-33) to "5 (IOL)" to receive inverter overload warning output signals.                 |
| Lost Command   | The Lost Command warning alarm occurs even when PRT-12 is set to "0". The warning alarm occurs based on the condition set at PRT-13-15. Set the digital output terminal or relay (OUT31-33) to "12 (Lost Command)" to receive lost command warning output signals. |
| Fan Warning    | Displayed when an error is detected from the cooling fan while PRT-79 is set to "1". Set the digital output terminal or relay (OUT31-33) to "8 (Fan Warning)" to receive fan warning output signals.   |
| DB Warn %ED    | Displayed when the DB resistor usage rate exceeds the set value. Set the detection level at PRT-66.  |
| Enc Conn Check | Displayed when "3 (Enc Test)" is set at BAS-20 (Auto Tuning) and no signal is input during the encoder test. Set the ENC Tune at OUT31-33 to release a signal.   |
| Enc Dir Check  | Displayed when "3 (Enc Test)" is set at BAS-20 (Auto Tuning) and the settings for A and B encoder phases are changed or are the opposite during the encoder test. Set the ENC Dir at OUT31-33 to release a signal.   |
| Lost Keypad    | Displayed when operating commands come from the keypad or there is any problem with the communication between the keypad and inverter's main body in Keypad JOG mode after setting PRT-11 (Lost KPD Mode) to "0". Set the Lost Keypad (29) at OUT31-33.            |
| Check Line PLZ | Displayed when there is any problem with communication between the keypad and the iS7 Control CPU (control connection cables).   |
| Fire Mode      | Displayed when the fire function is activated. If a contact signal output is required, set the Fire Mode (37) at OUT31-33.   |
| PID Sleep      | Displayed in PID Sleep mode. This warning is provided to distinguish the PID sleep mode from a stopped state.  |
| AUX Power On   | Displayed when the control power is supplied with the auxiliary power module. If the auxiliary power module has been installed, an AUX Power On warning is provided instead of a Low Voltage trip when the main power is turned off.                               |

## 12.3 Troubleshooting Fault Trips

| Type                      | Problem  | Solution  |
|---------------------------|--|---|
| Over Load                 | The load is greater than the motor's rated capacity.   | Ensure that the motor and inverter have appropriate capacity ratings.                       |
|                           | The set value for the overload trip level (PRT-21) is too low.   | Increase the set value for the overload trip level.   |
| Under Load                | There is a motor-load connection problem.  | Replace the motor and inverter with lower capacity models.                                  |
|                           | The set value for the underload level (PRT-29 and PRT-30) is less than the system's minimum load.                | Increase the set value for the underload level.   |
| Over Current1             | Acc/dec time is too short compared to load inertia (GD2).  | Increase acc/dec time.  |
|                           | The inverter load is greater than the rated capacity.  | Replace the inverter with a model that has increased capacity.                              |
|                           | The inverter supplied an output while the motor was idling.  | Operate the inverter after the motor has stopped or use the speed search function (CON-60). |
|                           | The mechanical brake of the motor is operating too fast.   | Check the mechanical brake.   |
| Over Voltage              | The deceleration time is too short for the load inertia (GD2).   | Increase the deceleration time.   |
|                           | A generative load occurs at the inverter output.   | Use the braking unit.   |
|                           | The input voltage is too high.   | Check if the input voltage is above the specified value.                                    |
|                           | The set value for electronic thermal protection is too low.  | Set an appropriate electronic thermal level.  |
|                           | The inverter has been operated at a low speed for an extended period.  | Replace the motor with a model that supplies extra power to the cooling fan.                |
| Low Voltage /Low Voltage2 | The input voltage is too low.  | Check if the input voltage is below the specified value.                                    |
|                           | A load greater than the power capacity is connected to the system (e.g. a welder, direct motor connection, etc.) | Increase the power capacity.  |
|                           | The magnetic contactor connected to the power source has a faulty connection.                                    | Replace the magnetic contactor.   |
| Ground Trip               | A ground fault has occurred in the inverter output wiring.   | Check the output wiring.  |

| Type           | Problem  | Solution   |
|----------------|--|--|
|                | The motor insulation is damaged.   | Replace the motor.   |
| E-Thermal      | The motor has overheated.  | Reduce the load or operation frequency.  |
|                | The inverter load is greater than the rated capacity.                    | Replace the inverter with a model that has increased capacity.                           |
| Out Phase Open | The magnetic contactor on the output side has a connection fault.        | Check the magnetic contactor on the output side.   |
|                | The output wiring is faulty.   | Check the output wiring.   |
| In Phase Open  | The magnetic contactor on the input side has a connection fault.         | Check the magnetic contactor on the input side.  |
|                | The input wiring is faulty.  | Check the input wiring.  |
|                | The DC link capacitor needs to be replaced.                              | Replace the DC link capacitor. Contact the retailer or the LS ELECTRIC Customer Support. |
| Inverter OLT   | The load is greater than the rated motor capacity.                       | Replace the motor and inverter with models that have increased capacity.                 |
|                | The torque boost level is too high.                                      | Reduce the torque boost level.   |
| Over Heat      | There is a problem with the cooling system.                              | Check if a foreign object is obstructing the air inlet, outlet, or vent.                 |
|                | The inverter cooling fan has been operating for an extended period.      | Replace the cooling fan.   |
|                | The ambient temperature is too high.                                     | Keep the ambient temperature below 50°C.   |
| Over Current2  | The output wiring has short-circuited.                                   | Check the output wiring.   |
|                | There is a fault with the electronic semiconductor (IGBT).               | Do not operate the inverter. Contact the retailer or the LS ELECTRIC Customer Support.   |
| NTC Open       | The ambient temperature is too low.                                      | Keep the ambient temperature above 10°C.   |
|                | There is a fault with the internal temperature sensor.                   | Contact the retailer or the LS ELECTRIC Customer Support.                                |
| FAN Trip       | There is a foreign object in the inverter vent where the fan is located. | Remove the foreign object from the air inlet or outlet.                                  |
|                | The cooling fan needs to be replaced.                                    | Replace the cooling fan.   |
| IP54 FAN Trip  | The fan connector is not connected.                                      | Connect the fan connector.   |
|                | The power connector for the internal fan PCB board is not connected.     | Connect the power connector for the internal fan PCB board.                              |
|                | The cooling fan needs to be replaced.                                    | Replace the cooling fan.   |



| Type          | Problem   | Solution   |
|---------------|---|--|
| No Motor Trip | The motor is not connected to the inverter output.        | Check the wiring connections.  |
|               | The current level for trip detection is not set properly. | Check the values of both BAS-13 (Rated current) and PRT-32 (No Motor Level). |

## 12.4 Replacing the Cooling Fan

### 12.4.1 Products Rated below 7.5 kW

To replace the cooling fan, push the bracket on the bottom in the direction of the arrows in the diagram below and then pull it forward. Then, disconnect the fan connector.

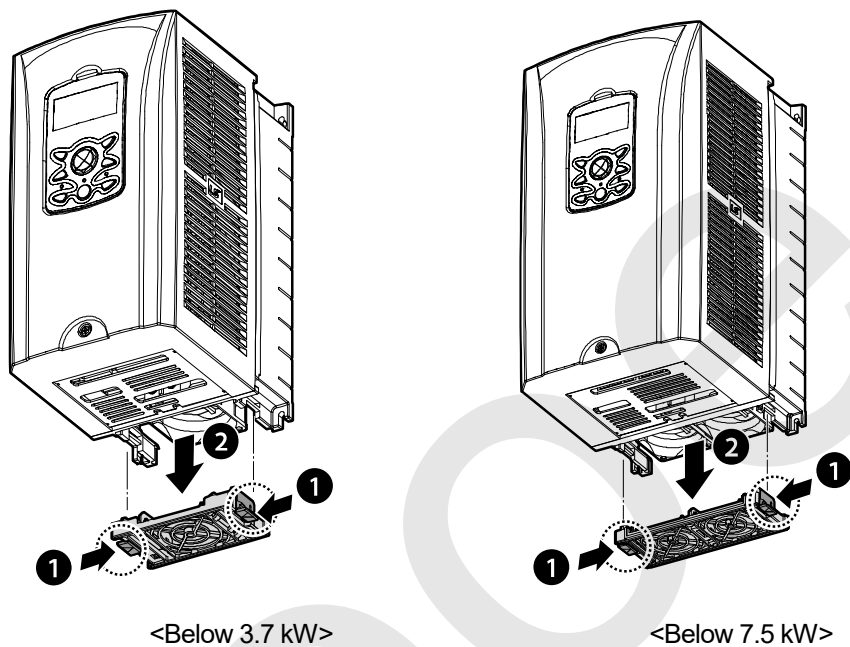

### 12.4.2 Products Rated at 11-15 kW 200 V/400 V and 18.5-22 kW 400 V

To replace the cooling fan, loosen the screws at the bottom of the input and output terminals and disconnect the fan connector.

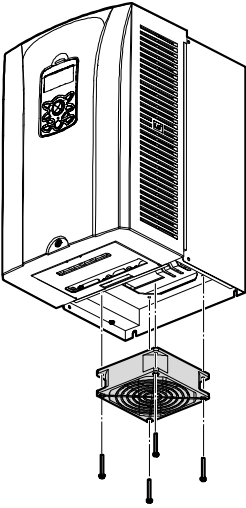

### 12.4.3 Products Rated at more than 30 kW (200 V) / 90 kW (400 V), and 18.5–22 kW (200 V) / 30–75 kW (200/400 V)

To replace the cooling fan, loosen the screws at the top of the product and disconnect the fan connector.

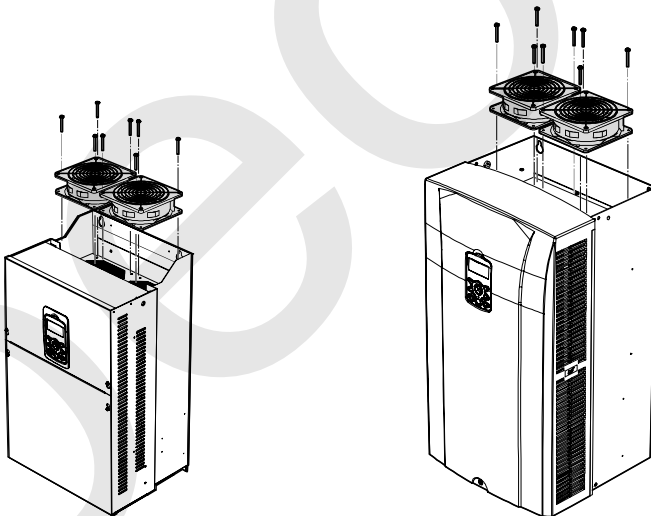

Model types > 30 kW (200 V) ,  
Model types > 90 kW (400 V)

18.5–22 kW (200 V),  
30–75 kW (400V)

## 12.5 Daily and Regular Inspection Lists

| Inspection area      | Inspection item     | Inspection details  | Inspection Cycle |                |   | Inspection method  | Judgment standard   | Inspection equipment              |
|----------------------|---------------------|---|------------------|----------------|---|--|---|-----------------------------------|
|                      |                     |   | Daily            | Regular (Year) |   |  |   |                                   |
|                      |                     |   |                  | 1              | 2 |  |   |                                   |
| Total                | Ambient environment | Is the ambient temperature and humidity within the designated range, and is there any dust or foreign objects present?  | O                |                |   | Visual inspection  | No ice (ambient temperature: -10°C →+40°C) and no condensation (ambient humidity below 50%) | Thermometer, hygrometer, recorder |
|                      | Inverter            | Are there any abnormal vibrations or noise?   | O                |                |   | Visual inspection  | No abnormality  |                                   |
|                      | Power voltage       | Are the input and output voltages normal?   | O                |                |   | Measure voltages between R/S/T phases in the inverter terminal block.  |   | Digital multimeter, tester        |
| Input/Output circuit | Total               | 1) Megger test (between input/output terminals and and earth terminal)<br>2) Is there anything loose in the device?<br>3) Is there any evidence of overheating in each part?<br>4) Cleaning |                  | O              | O | 1) Disconnect the inverter and short R/S/T/U/V/W terminals, and then measure from each terminal to the ground terminal using Megger test equipment.<br>2) Tighten up all screws.<br>3) Visual inspection | 1) Over 5MΩ<br>2), 3) No matter   | DC 500 V Megger                   |
|                      | Cable connections   | 1) Are there any corroded cables?<br>2) Is there any damage to cable insulation?  |                  | O              | O | Visual inspection  | No abnormality  |                                   |
|                      | Terminal block      | Is there any damage?  |                  | O              |   | Visual inspection  | No abnormality  |                                   |
|                      | Smoothing condenser | 1) Is liquid leaking inside?<br>2) Is the safety apparatus in position? Is there any protuberance?  | O<br>O<br>O      |                |   | 1), 2) Visual inspection   | 1),2) No abnormality  | Capacity meter                    |

Function Table

| Inspection area | Inspection item  | Inspection details  | Inspection Cycle |                |   | Inspection method   | Judgment standard   | Inspection equipment               |
|-----------------|------------------|---|------------------|----------------|---|---|---|------------------------------------|
|                 |                  |   | Daily            | Regular (Year) |   |   |   |                                    |
|                 |                  |   |                  | 1              | 2 |   |   |                                    |
|                 |                  | 3) Check the power failure capacity.  |                  |                |   | 3) Measure with a capacity meter.   | 3) Rated capacity over 85%  |                                    |
|                 | Relay            | 1) Is there any chattering noise during operation?<br>2) Is there any damage to the contacts? |                  | O              |   | 1), 2) Visual inspection  | 1),2) No abnormality  |                                    |
|                 | Braking resistor | 1) Is there any damage from resistance?<br>2) Check for disconnection.                        |                  | O              |   | 1) Visual inspection<br>2) Disconnect one side and measure with a tester. | 1) No abnormality<br>2) Must be within $\pm 10\%$ of the rated value of the resistor. | Digital multimeter / analog tester |

### ⚠ Caution

Do not perform a megger test (insulation resistance test) on the control circuit of the inverter.

| Inspection area                    | Inspection item      | Inspection details   | Inspection Cycle |                |   | Inspection method  | Judgment standard  | Inspection equipment               |
|------------------------------------|----------------------|--|------------------|----------------|---|--|--|------------------------------------|
|                                    |                      |  | Daily            | Regular (Year) |   |  |  |                                    |
|                                    |                      |  |                  | 1              | 2 |  |  |                                    |
| Control circuit Protection circuit | Operation check      | 1) Check for output voltage imbalance while the inverter is in operation.<br>2) Is there an error in the display circuit after the sequence protection test? |                  | O              |   | 1) Measure voltage between the inverter output terminals U/V/W.<br>2) Test the inverter output protection in both short and open circuit conditions. | 1) Balance the voltage between the phases: within 4 V for 200 V series and within 8 V for 400 V series.<br>2) The circuit must work according to the sequence. | Digital multimeter or DC voltmeter |
| Cooling system                     | Cooling fan          | 1) Is there any abnormal vibration or sound?<br>2) Are any of the fan parts loose?   | O                |                | O | 1) Turn it manually while the inverter is turned off.<br>2) Check all connected parts and tighten all screws.  | 1) It should turn smoothly.<br>2) No abnormality   |                                    |
| Display                            | Meter                | Is the display value normal?   | O                |                | O | Check the command value on the display device.   | Specified and managed values must match.   | Voltmeter, ammeter, etc.           |
| Motor                              | Total                | 1) Are there any abnormal vibrations or sound?<br>2) Is there any abnormal smell?  | O                |                | O | 1) Visual inspection<br>2) Check the abnormality, such as overheating, damage, etc.  | No abnormality   |                                    |
|                                    | Isolation resistance | Megger test (between the input, output and earth terminals).   |                  |                | O | Disconnect the cables for terminals U/V/W and test the wiring.   | Must be above 5 MΩ.  | DC 500 V Megger                    |

Function Table

**⚠ Caution**

If the inverter has not been operated for a long time, capacitors lose their charging capability and are depleted. To prevent depletion, turn on the inverter once a year and allow it to operate for 30-60 minutes. Run the inverter under no-load conditions.

# 13 Table of Functions

## 13.1 Parameter Mode – DRV Group (→DRV)

DRV Group (PAR → DRV)

| No.          | Communi-<br>cation<br>Address | LCD Display      | Name                          | Setting Range                                    | Initial Value                        | Shift in<br>Opera-<br>tion | Page | Note1)<br>Control Mode |        |        |             |             |   |   |  |
|--------------|-------------------------------|------------------|-------------------------------|--|--------------------------------------|----------------------------|------|------------------------|--------|--------|-------------|-------------|---|---|--|
|              |                               |                  |                               |  |                                      |                            |      | V<br>/<br>F            | S<br>L | V<br>C | S<br>L<br>T | V<br>C<br>T |   |   |  |
| 00           | -                             | Jump Code        | Jump code                     | 1-99   | 9                                    | O                          |      | O                      | O      | O      | O           | O           |   |   |  |
| 01           | 0h1101                        | Cmd<br>Frequency | Target frequency              | Starting frequency<br>-maximum frequency<br>(Hz) | 0.0                                  | O                          | 138  | O                      | O      | O      | X           | X           |   |   |  |
| 02           | 0h1102                        | Cmd Torque       | Torque command                | -180~180 (%)                                     | 0.0                                  | O                          | 236  | X                      | X      | X      | O           | O           |   |   |  |
| 03           | 0h1103                        | Acc Timed        | Acceleration time             | 0~600 (sec)                                      | Below 75 kW 20.0<br>Above 90 kW 60.0 | O                          | 165  | O                      | O      | O      | O           | O           |   |   |  |
| 04           | 0h1104                        | Dec Time         | Deceleration time             | 0~600 (sec)                                      | Below 75 kW 30.0<br>Above 90 kW 90.0 | O                          | 165  | O                      | O      | O      | O           | O           |   |   |  |
| 06           | 0h1106                        | Cmd Source       | Command source                | 0  | Keypad                               | 1:Fx/Rx-1                  | X    | 157                    | O      | O      | O           | O           | O | O |  |
|              |                               |                  |                               | 1  | Fx/Rx-1                              |                            |      |                        |        |        |             |             |   |   |  |
|              |                               |                  |                               | 2  | Fx/Rx-2                              |                            |      |                        |        |        |             |             |   |   |  |
|              |                               |                  |                               | 3  | Int 485                              |                            |      |                        |        |        |             |             |   |   |  |
|              |                               |                  |                               | 4  | Field Bus                            |                            |      |                        |        |        |             |             |   |   |  |
| 5            | PLC                           |                  |                               |  |                                      |                            |      |                        |        |        |             |             |   |   |  |
| 07           | 0h1107                        | Freq Ref Src     | Frequency reference<br>source | 0  | Keypad-1                             | 0:Keypad-1                 | X    | 138                    | O      | O      | O           | X           | X |   |  |
|              |                               |                  |                               | 1  | Keypad-2                             |                            |      |                        |        |        |             |             |   |   |  |
|              |                               |                  |                               | 2  | V1                                   |                            |      |                        |        |        |             |             |   |   |  |
| 08           | 0h1108                        | Trq Ref Src      | Torque reference<br>source    | 3  | I1                                   | 0:Keypad-1                 | X    | 237                    | X      | X      | X           | O           | O |   |  |
|              |                               |                  |                               | 4  | V2                                   |                            |      |                        |        |        |             |             |   |   |  |
|              |                               |                  |                               | 5  | I2                                   |                            |      |                        |        |        |             |             |   |   |  |
|              |                               |                  |                               | 6  | Int 485                              |                            |      |                        |        |        |             |             |   |   |  |
|              |                               |                  |                               | 7  | Encoder                              |                            |      |                        |        |        |             |             |   |   |  |
|              |                               |                  |                               | 8  | FieldBus                             |                            |      |                        |        |        |             |             |   |   |  |
|              |                               |                  |                               | 9  | PLC                                  |                            |      |                        |        |        |             |             |   |   |  |
|              |                               |                  |                               | 10   | Synchro                              |                            |      |                        |        |        |             |             |   |   |  |
|              |                               |                  |                               | 11   | Binary                               |                            |      |                        |        |        |             |             |   |   |  |
| 09<br>Note1) | 0h1109                        | Control Mode     | Control mode                  | 0  | V/F                                  | 0:V/F                      | X    | 267                    | O      | O      | O           | O           | O |   |  |
|              |                               |                  |                               | 1  | V/F PG                               |                            |      | 225                    |        |        |             |             |   |   |  |
|              |                               |                  |                               | 2  | Slip Compen                          |                            |      | 210                    |        |        |             |             |   |   |  |
|              |                               |                  |                               | 3  | Sensorless-1                         |                            |      | 225                    |        |        |             |             |   |   |  |
|              |                               |                  |                               | 4  | Sensorless-2                         |                            |      | 227                    |        |        |             |             |   |   |  |
|              |                               |                  |                               | 5  | Vector                               |                            |      | 238                    |        |        |             |             |   |   |  |

\*  The grey cells indicate a hidden code which is only visible when setting a code.

Note 1) Effectiveness of each code according to the Control Mode setting.

V/F: V/Fmode (PG included), SL: Sensorless-1, 2 mode, VC: Vector mode, SLT: Sensorless-1, 2 Torque mode,

VCT: Vector Torque mode,

Refer to the Options manual for options.

DRV Group (PAR → DRV)

| No.                          | Communi-<br>cation<br>Address | LCD Display       | Name                         | Setting Range   | Initial Value                        | Shift in<br>Opera-<br>tion | Page | Control<br>Mode |        |        |             |             |
|------------------------------|-------------------------------|-------------------|------------------------------|---|--------------------------------------|----------------------------|------|-----------------|--------|--------|-------------|-------------|
|                              |                               |                   |                              |   |                                      |                            |      | V<br>/<br>F     | S<br>L | V<br>C | S<br>L<br>T | V<br>C<br>T |
| 10                           | 0h110A                        | Torque Control    | Torque control               | 0   No<br>1   Yes   | 0: No                                | X                          | 225  | X               | X      | X      | O           | O           |
| 11                           | 0h110B                        | Jog<br>Frequency  | Jog frequency                | 0.5–maximum<br>frequency (Hz)   | 10.00                                | O                          | 199  | O               | O      | O      | O           | O           |
| 12                           | 0h110C                        | Jog Acc Time      | Jog run<br>acceleration time | 0–600 (sec)   | 20.0                                 | O                          | 199  | O               | O      | O      | O           | O           |
| 13                           | 0h110D                        | Jog Dec Time      | Jog run<br>deceleration time | 0–600 (sec)   | 30.0                                 | O                          | 199  | O               | O      | O      | X           | X           |
| 14                           | 0h110E                        | Motor<br>Capacity | Motor capacity               | 0:0.2kW, 1:0.4kW<br>2:0.75kW, 3:1.5kW<br>4:2.2kW, 5:3.7kW<br>6:5.5kW, 7:7.5kW<br>8:11kW, 9:15kW<br>10:18.5kW, 11:22kW<br>12:30kW, 13:37kW<br>14:45kW, 15:55kW<br>16:75kW, 17:90kW<br>18:110kW, 9:132kW<br>20:160kW, 1:185kW<br>22:220kW,23:280kW<br>24:315kW,25:375kW<br>26:450kW | Dependent on<br>inverter capacity    | X                          | 211  | O               | O      | O      | O           | O           |
| 15                           | 0h110F                        | Torque Boost      | Torque boost<br>method       | 0   Manual<br>1   Auto<br>2   Advanced Auto   | 0:Manual                             | X                          | 179  | O               | X      | X      | X           | X           |
| 16<br><small>Note 2)</small> | 0h1110                        | Fwd Boost         | Forward torque<br>boost      | 0–15 (%)  | Below 75kW   2.0<br>Above 90kW   1.0 | X                          | 179  | O               | X      | X      | X           | X           |
| 17                           | 0h1111                        | Rev Boost         | Reverse torque<br>boost      | 0–15(%)   | Below 75kW   2.0<br>Above 90kW   1.0 | X                          | 179  | O               | X      | X      | X           | X           |
| 18                           | 0h1112                        | Base Freq         | Base frequency               | 30–400 (Hz)   | 60.00                                | X                          | 174  | O               | O      | O      | O           | O           |
| 19                           | 0h1113                        | Start Freq        | Starting frequency           | 0.01–10 (Hz)  | 0.50                                 | X                          | 174  | O               | X      | X      | X           | X           |
| 20                           | 0h1114                        | Max Freq          | Maximum<br>frequency         | 40–400  | 60.00                                | X                          | 186  | O               | O      | O      | O           | O           |
| 21                           | 0h1115                        | Hz/Rpm Sel        | Speed unit<br>selection      | 0   Hz Display<br>1   Rpm Display   | 0:Hz                                 | O                          | 287  | O               | O      | O      | O           | O           |
| 25                           | 0h1119                        | Output Freq       | Output speed<br>monitoring   | 0-Max Frequency   | 0.00                                 | O                          | 288  | O               | O      | O      | O           | O           |

\*  The grey cells indicate a hidden code which is only visible when setting a code.

Note 2) DRV-16–17 displayed only when DRV-15 (Torque Boost) is set as “Manual” or “Advanced Auto”.

Function  
Table



## Table of Functions

### DRV Group (PAR → DRV)

| No.                         | Communi-<br>cation<br>Address | LCD Display       | Name                     | Setting Range | Initial Value | Shift in<br>Opera-<br>tion | Page | Control<br>Mode |        |        |             |             |
|-----------------------------|-------------------------------|-------------------|--------------------------|---------------|---------------|----------------------------|------|-----------------|--------|--------|-------------|-------------|
|                             |                               |                   |                          |               |               |                            |      | V<br>/<br>F     | S<br>L | V<br>C | S<br>L<br>T | V<br>C<br>T |
| 26<br><small>Note2)</small> | 0h111A                        | Adv ATB Filter    | Adv ATB Filter           | 1~1000[msec]  | 100           | O                          | 179  | X               | X      | X      | O           | O           |
| 27                          | 0h111B                        | Adv ATB M<br>Gain | Adv ATB M Gain           | 0~300.0[%]    | 50.0          | O                          | 179  | O               | O      | O      | O           | O           |
| 28                          | 0h111C                        | Adv ATB G<br>Gain | Adv ATB G Gain           | 0~300.0[%]    | 50.0          | O                          | 179  | O               | O      | O      | O           | O           |
| 30                          | 0h111E                        | kW/HP Select      | kW/HP Select             | 0 kW<br>1 HP  | 0: kW         | O                          | 282  | O               | O      | O      | X           | X           |
| 87                          | 0h1157                        | Code Version      | Inverter Code<br>Version | -             | -             | X                          | -    | O               | O      | O      | O           | O           |

\*  The grey cells indicate a hidden code which is only visible when setting a code.

Note 3) ) DRV-26~28 code is displayed only when DRV-15 (Torque Boost) code value is "Advanced Auto

## 13.2 Parameter Mode – Basic Function Group (→BAS)

### BAS Group(PAR → BAS)

| No.                         | Communi-<br>cation<br>Address | LCD Display      | Name                                     | Setting Range    | Initial Value       | Shift in<br>Opera-<br>tion | Page | Control Mode |        |        |             |             |   |
|-----------------------------|-------------------------------|------------------|--|------------------|---------------------|----------------------------|------|--------------|--------|--------|-------------|-------------|---|
|                             |                               |                  |  |                  |                     |                            |      | V<br>/<br>F  | S<br>L | V<br>C | S<br>L<br>T | V<br>C<br>T |   |
| 00                          | -                             | Jump Code        | Jump code                                | 0-99             | 20                  | O                          |      | O            | O      | O      | O           | O           |   |
| 01                          | 0h1201                        | Aux Ref Src      | Auxiliary<br>reference source            | 0                | None                | 0:None                     | X    | 194          | O      | O      | O           | X           | X |
|                             |                               |                  |  | 1                | V1                  |                            |      |              |        |        |             |             |   |
|                             |                               |                  |  | 2                | I1                  |                            |      |              |        |        |             |             |   |
|                             |                               |                  |  | 3                | V2                  |                            |      |              |        |        |             |             |   |
|                             |                               |                  |  | 4                | I2                  |                            |      |              |        |        |             |             |   |
|                             |                               |                  |  | 5                | Pulse               |                            |      |              |        |        |             |             |   |
| 02<br><small>Note3)</small> | 0h1202                        | Aux Calc<br>Type | Auxiliary<br>command<br>calculation type | 0                | $M+(G^*A)$          | 0: $M+(G^*A)$              | X    | 194          | O      | O      | O           | X           | X |
|                             |                               |                  |  | 1                | $M^*(G^*A)$         |                            |      |              |        |        |             |             |   |
|                             |                               |                  |  | 2                | $M/(G^*A)$          |                            |      |              |        |        |             |             |   |
|                             |                               |                  |  | 3                | $M+(M^*(G^*A))$     |                            |      |              |        |        |             |             |   |
|                             |                               |                  |  | 4                | $M+G^*2(A-50\%)$    |                            |      |              |        |        |             |             |   |
|                             |                               |                  |  | 5                | $M^*(G^*2(A-50\%))$ |                            |      |              |        |        |             |             |   |
|                             |                               |                  |  | 6                | $M/(G^*2(A-50\%))$  |                            |      |              |        |        |             |             |   |
|                             |                               |                  |  | 7                | $M+M^*G^*2(A-50\%)$ |                            |      |              |        |        |             |             |   |
| 03                          | 0h1203                        | Aux Ref Gain     | Auxiliary<br>command<br>gain             | -200.0–200.0 (%) | 100.0               | O                          |      | 194          | O      | O      | O           | X           | X |
| 04                          | 0h1204                        | Cmd 2nd Src      | Second<br>command source                 | 0                | Keypad              | 1: Fx/Rx-1                 | X    | 190          | O      | O      | O           | O           | O |
|                             |                               |                  |  | 1                | Fx/Rx-1             |                            |      |              |        |        |             |             |   |
|                             |                               |                  |  | 2                | Fx/Rx-2             |                            |      |              |        |        |             |             |   |
|                             |                               |                  |  | 3                | Int 485             |                            |      |              |        |        |             |             |   |
|                             |                               |                  |  | 4                | FieldBus            |                            |      |              |        |        |             |             |   |
|                             |                               |                  |  | 5                | PLC                 |                            |      |              |        |        |             |             |   |
| 05                          | 0h1205                        | Freq 2nd Src     | Second frequency<br>source               | 0 Keypad-1       | 0:Keypad-1          | O                          |      | 190          | O      | O      | O           | X           | X |

\*  The grey cells indicate a hidden code which is only visible when setting a code.

Note 3) BAS-02 code is displayed only when BAS-01 (Aux Ref Src) code has a value other than "None".

# Table of Functions

## BAS Group (PAR → BAS)

| No. | Communication Address | LCD Display   | Name                         | Setting Range | Initial Value                  | Shift in Operation | Page | Control Mode |     |     |       |       |   |     |
|-----|-----------------------|---------------|------------------------------|---------------|--------------------------------|--------------------|------|--------------|-----|-----|-------|-------|---|-----|
|     |                       |               |                              |               |                                |                    |      | V / F        | S L | V C | S L T | V C T |   |     |
| 06  | 0h1206                | Trq 2nd Src   | Second torque command source | 1             | Keypad-2                       | 0:Keypad-1         | O    | 190          | X   | X   | X     | O     | O |     |
|     |                       |               |                              | 2             | V1                             |                    |      |              |     |     |       |       |   |     |
|     |                       |               |                              | 3             | I1                             |                    |      |              |     |     |       |       |   |     |
|     |                       |               |                              | 4             | V2                             |                    |      |              |     |     |       |       |   |     |
|     |                       |               |                              | 5             | I2                             |                    |      |              |     |     |       |       |   |     |
|     |                       |               |                              | 6             | Int 485                        |                    |      |              |     |     |       |       |   |     |
|     |                       |               |                              | 7             | Encoder                        |                    |      |              |     |     |       |       |   |     |
|     |                       |               |                              | 8             | FieldBus                       |                    |      |              |     |     |       |       |   |     |
|     |                       |               |                              | 9             | PLC                            |                    |      |              |     |     |       |       |   |     |
|     |                       |               |                              | 10            | Synchro                        |                    |      |              |     |     |       |       |   |     |
|     |                       |               |                              | 11            | Binary Type                    |                    |      |              |     |     |       |       |   |     |
|     |                       |               |                              | 12            | Keypad-2                       |                    |      |              |     |     |       |       |   |     |
| 07  | 0h1207                | V/F Pattern   | V/F pattern options          | 0             | Linear                         | 0:Linear           | X    | 175          | O   | O   | X     | X     | X |     |
|     |                       |               |                              | 1             | Square                         |                    |      |              |     |     |       |       |   |     |
|     |                       |               |                              | 2             | User V/F                       |                    |      |              |     |     |       |       |   |     |
|     |                       |               |                              | 3             | Square2                        |                    |      |              |     |     |       |       |   |     |
| 08  | 0h1208                | Ramp T Mode   | Acc/Dec standard frequency   | 0             | Max Freq                       | 0:Max Freq         | X    | 165          | O   | O   | O     | X     | X |     |
|     |                       |               |                              | 1             | Delta Freq                     |                    |      |              |     |     |       |       |   |     |
| 09  | 0h1209                | Time Scale    | Time scale settings          | 0             | 0.01 sec                       | 1:0.1 sec          | X    | 165          | O   | O   | O     | X     | X |     |
|     |                       |               |                              | 1             | 0.1 sec                        |                    |      |              |     |     |       |       |   |     |
|     |                       |               |                              | 2             | 1 sec                          |                    |      |              |     |     |       |       |   |     |
| 10  | 0h120A                | 60/50 Hz Sel  | Input power frequency        | 0             | 60 Hz                          | 0:60 Hz            | X    | 84           | O   | O   | O     | O     | O |     |
|     |                       |               |                              | 1             | 50 Hz                          |                    |      |              |     |     |       |       |   |     |
| 11  | 0h120B                | Pole Number   | Number of motor poles        | 248           |                                | X                  |      |              | O   | O   | O     | O     | O |     |
| 12  | 0h120C                | Rated Slip    | Rated slip speed             | 0-3000 (rpm)  | Dependent on inverter capacity | X                  |      |              | O   | O   | O     | O     | O |     |
| 13  | 0h120D                | Rated Curr    | Motor rated current          | 1-1000 (A)    |                                | X                  |      |              | O   | O   | O     | O     | O |     |
| 14  | 0h120E                | Noload Curr   | Motor no-load current        | 0.5-1000 (A)  |                                | X                  |      |              | O   | O   | O     | O     | O |     |
| 15  | 0h120F                | Rated Volt    | Motor rated voltage          | 180-480 (V)   |                                | 0                  | X    |              |     | O   | O     | O     | O | O   |
| 16  | 0h1210                | Efficiency    | Motor efficiency             | 70-100 (%)    | Dependent on inverter capacity | X                  |      |              | O   | O   | O     | O     | O |     |
| 17  | 0h1211                | Inertia Rate  | Load inertia rate            | 0-8           | Dependent on inverter capacity | X                  |      |              | O   | O   | O     | O     | O |     |
| 18  | 0h1212                | Trim Power %  | Power display adjustment     | 70-130 (%)    |                                | O                  |      |              | 286 | O   | O     | O     | O | O   |
| 19  | 0h1213                | AC Input Volt | Input power voltage          | 170-230 (V)   | 220 V                          | O                  | 263  | O            | O   | O   | O     | O     | O |     |
|     |                       |               |                              | 380-480 (V)   | 44x0 V                         |                    |      |              |     |     |       |       |   | 220 |
| 20  | -                     | Auto Tuning   | Auto tuning                  | 0             | None                           | 0:None             | X    | 220          | X   | O   | O     | O     | O | O   |
|     |                       |               |                              | 1             | All                            |                    |      |              |     |     |       |       |   |     |
|     |                       |               |                              | 2             | ALL(Stdsl)                     |                    |      |              |     |     |       |       |   |     |
|     |                       |               |                              | 3             | Rs+Lsigma                      |                    |      |              |     |     |       |       |   |     |
|     |                       |               |                              | 4             | Enc Test                       |                    |      |              |     |     |       |       |   |     |
|     |                       |               |                              | 5             | Tr                             |                    |      |              |     |     |       |       |   |     |
| 6   | Tr(Stdsl)             |               |                              |               |                                |                    |      |              |     |     |       |       |   |     |

## BAS Group (PAR → BAS)

| No.                         | Communication Address | LCD Display  | Name                           | Setting Range                                | Initial Value | Shift in Operation | Page | Control Mode |       |       |       |       |   |   |
|-----------------------------|-----------------------|--------------|--------------------------------|--|---------------|--------------------|------|--------------|-------|-------|-------|-------|---|---|
|                             |                       |              |                                |  |               |                    |      | V / F        | S L C | V L C | S L T | V C T |   |   |
| 21                          | -                     | Rs           | Stator resistance              | Dependent on motor setting                   | -             | X                  | 220  | X            | O     | O     | O     | O     | O |   |
| 22                          | -                     | Lsigma       | Leakage inductance             | Dependent on motor setting                   | -             | X                  | 220  | X            | O     | O     | O     | O     | O |   |
| 23                          | -                     | Ls           | Stator inductance              | Dependent on motor setting                   | -             | X                  | 220  | X            | O     | O     | O     | O     | O |   |
| 24<br><small>Note4)</small> | -                     | Tr           | Rotor time constant            | 25-5000 (ms)                                 | -             | X                  | 220  | X            | O     | O     | O     | O     | O |   |
| 41<br><small>Note5)</small> | 0h1229                | User Freq 1  | User frequency 1               | 0-maximum frequency (Hz)                     | 15.00         | X                  | 176  | O            | X     | X     | X     | X     | X |   |
| 42                          | 0h122A                | User Volt 1  | User voltage 1                 | 0-100 (%)                                    | 25            | X                  | 176  | O            | X     | X     | X     | X     | X |   |
| 43                          | 0h122B                | User Freq 2  | User frequency 2               | 0-maximum frequency (Hz)                     | 30.00         | X                  | 176  | O            | X     | X     | X     | X     | X |   |
| 44                          | 0h122C                | User Volt 2  | User voltage 2                 | 0-100 (%)                                    | 50            | X                  | 176  | O            | X     | X     | X     | X     | X |   |
| 45                          | 0h122D                | User Freq 3  | User frequency 3               | 0-maximum frequency (Hz)                     | 45.00         | X                  | 176  | O            | X     | X     | X     | X     | X |   |
| 46                          | 0h122E                | User Volt 3  | User voltage 3                 | 0-100 (%)                                    | 75            | X                  | 176  | O            | X     | X     | X     | X     | X |   |
| 47                          | 0h122F                | User Freq 4  | User frequency 4               | 0-maximum frequency (Hz)                     | 60.00         | X                  | 176  | O            | X     | X     | X     | X     | X |   |
| 48                          | 0h1230                | User Volt 4  | User voltage 4                 | 0-100 (%)                                    | 100           | X                  | 176  | O            | X     | X     | X     | X     | X |   |
| 50<br><small>Note6)</small> | 0h1232                | Step Freq-1  | Multi-step speed frequency 1   | Starting frequency<br>-maximum frequency(Hz) | 10.00         | O                  | 154  | O            | O     | O     | X     | X     | X |   |
| 51                          | 0h1233                | Step Freq-2  | Multi-step speed frequency 2   |  | 20.00         | O                  | 154  | O            | O     | O     | O     | X     | X | X |
| 52                          | 0h1234                | Step Freq-3  | Multi-step speed frequency 3   |  | 30.00         | O                  | 154  | O            | O     | O     | O     | X     | X | X |
| 53                          | 0h1235                | Step Freq-4  | Multi-step speed frequency 4   |  | 40.00         | O                  | 154  | O            | O     | O     | O     | X     | X | X |
| 54                          | 0h1236                | Step Freq-5  | Multi-step speed frequency 5   |  | 50.00         | O                  | 154  | O            | O     | O     | O     | X     | X | X |
| 55                          | 0h1237                | Step Freq-6  | Multi-step speed frequency 6   |  | 60.00         | O                  | 154  | O            | O     | O     | O     | X     | X | X |
| 56                          | 0h1238                | Step Freq-7  | Multi-step speed frequency 7   |  | 60.00         | O                  | 154  | O            | O     | O     | O     | X     | X | X |
| 57                          | 0h1239                | Step Freq-8  | Multi-step speed frequency 8   |  | 55.00         | O                  | 154  | O            | O     | O     | O     | X     | X | X |
| 58                          | 0h123A                | Step Freq-9  | Multi-step speed frequency 9   |  | 50.00         | O                  | 154  | O            | O     | O     | O     | X     | X | X |
| 59                          | 0h123B                | Step Freq-10 | Multi-step speed frequency 10  |  | 45.00         | O                  | 154  | O            | O     | O     | O     | X     | X | X |
| 60                          | 0h123C                | Step Freq-11 | Multi-step speed frequency 11  |  | 40.00         | O                  | 154  | O            | O     | O     | O     | X     | X | X |
| 61                          | 0h123D                | Step Freq-12 | Multi-step speed frequency 12  |  | 35.00         | O                  | 154  | O            | O     | O     | O     | X     | X | X |
| 62                          | 0h123E                | Step Freq-13 | Multi-step speed frequency 13  |  | 25.00         | O                  | 154  | O            | O     | O     | O     | X     | X | X |
| 63                          | 0h123F                | Step Freq-14 | Multi-step speed frequency 14  |  | 15.00         | O                  | 154  | O            | O     | O     | O     | X     | X | X |
| 64                          | 0h1240                | Step Freq-15 | Multi-step speed frequency 15  |  | 5.00          | O                  | 154  | O            | O     | O     | O     | X     | X | X |
| 70                          | 0h1246                | Acc Time-1   | Multi-step acceleration time 1 | 0-600 (sec)                                  | 20.0          | O                  | 168  | O            | O     | O     | X     | X     | X |   |
| 71                          | 0h1247                | Dec Time-1   | Multi-step deceleration time 1 | 0-600 (sec)                                  | 20.0          | O                  | 168  | O            | O     | O     | X     | X     | X |   |

## Table of Functions

| No.                         | Communi-<br>cation<br>Address | LCD<br>Display | Name                           | Setting Range | Initial<br>Value | Shift in<br>Opera-<br>tion | Page | Control Mode |        |        |             |             |
|-----------------------------|-------------------------------|----------------|--------------------------------|---------------|------------------|----------------------------|------|--------------|--------|--------|-------------|-------------|
|                             |                               |                |                                |               |                  |                            |      | V<br>/<br>F  | S<br>L | V<br>C | S<br>L<br>T | V<br>C<br>T |
| 72<br><small>Note7)</small> | 0h1248                        | Acc Time-2     | Multi-step acceleration time 2 | 0-600 (sec)   | 30.0             | O                          | 168  | O            | O      | O      | X           | X           |
| 73                          | 0h1249                        | Dec Time-2     | Multi-step deceleration time 2 | 0-600 (sec)   | 30.0             | O                          | 168  | O            | O      | O      | X           | X           |
| 74                          | 0h124A                        | Acc Time-3     | Multi-step acceleration time 3 | 0-600 (sec)   | 40.0             | O                          | 168  | O            | O      | O      | X           | X           |
| 75                          | 0h124B                        | Dec Time-3     | Multi-step deceleration time 3 | 0-600 (sec)   | 40.0             | O                          | 168  | O            | O      | O      | X           | X           |
| 76                          | 0h124C                        | Acc Time-4     | Multi-step deceleration time 4 | 0-600 (sec)   | 50.0             | O                          | 168  | O            | O      | O      | X           | X           |
| 77                          | 0h124D                        | Dec Time-4     | Multi-step deceleration time 4 | 0-600 (sec)   | 50.0             | O                          | 168  | O            | O      | O      | X           | X           |
| 78                          | 0h124E                        | Acc Time-5     | Multi-step deceleration time 5 | 0-600 (sec)   | 60.0             | O                          | 168  | O            | O      | O      | X           | X           |
| 79                          | 0h124F                        | Dec Time-5     | Multi-step deceleration time 5 | 0-600 (sec)   | 60.0             | O                          | 168  | O            | O      | O      | X           | X           |
| 80                          | 0h1250                        | Acc Time-6     | Multi-step deceleration time 6 | 0-600 (sec)   | 70.0             | O                          | 168  | O            | O      | O      | X           | X           |
| 81                          | 0h1251                        | Dec Time-6     | Multi-step deceleration time 6 | 0-600 (sec)   | 70.0             | O                          | 168  | O            | O      | O      | X           | X           |
| 82                          | 0h1252                        | Acc Time-7     | Multi-step deceleration time 7 | 0-600 (sec)   | 80.0             | O                          | 168  | O            | O      | O      | X           | X           |
| 83                          | 0h1253                        | Dec Time-7     | Multi-step deceleration time 7 | 0-600 (sec)   | 80.0             | O                          | 168  | O            | O      | O      | X           | X           |

\*  The grey cells indicate a hidden code which is only visible when setting a code.

\*  The grey cells indicate a hidden code which is only visible when setting a code.

Note 4) BAS-24 is shown only when DRV-09 Control Mode is set to "Sensorless-2" or "Vector".

Note 5) BAS-41-48 is displayed only when it is set as "User V/F" even if there is only one BAS-07 or M2-V/F Patt (M2-25).

Note 6) IN-50-64 is displayed only when it is set as "multi-step speed" (Speed -L,M,H,X) even if there is only one among multi-function input IN-65-72.

Note 7) displayed only when it is set as "multi-step Acc/Dec" (Xcel-L,M,H) even if there is only one among multi-function input IN-72-75.

## 13.3 Parameter Mode – Expansion Function Group (PAR→ADV)

### Expansion Function Group (PAR → ADV)

| No.          | Communi-<br>cation<br>Address | LCD Display    | Name  | Setting Range                                 | Initial<br>Value | Shift in<br>Opera-<br>tion | Page | Control Mode |        |        |             |             |
|--------------|-------------------------------|----------------|---|---|------------------|----------------------------|------|--------------|--------|--------|-------------|-------------|
|              |                               |                |   |   |                  |                            |      | V<br>/<br>F  | S<br>L | V<br>C | S<br>L<br>T | V<br>C<br>T |
| 00           | -                             | Jump Code      | Jump code                                     | 0-99  | 24               | O                          | -    | O            | O      | O      | O           | O           |
| 01           | 0h1301                        | Acc Pattern    | Acceleration pattern                          | 0 Linear                                      | 0:Linear         | X                          | 171  | O            | O      | O      | X           | X           |
| 02           | 0h1302                        | Dec Pattern    | Deceleration pattern                          | 1 S-curve                                     |                  | X                          | 171  | O            | O      | O      | X           | X           |
| 03           | 0h1303                        | Acc S Start    | S-curve acceleration start<br>point gradient  | 1-100 (%)                                     | 40               | X                          | 171  | O            | O      | O      | X           | X           |
| 04           | 0h1304                        | Acc S End      | S-curve acceleration end<br>point gradient    | 1-100 (%)                                     | 40               | X                          | 171  | O            | O      | O      | X           | X           |
| 05           | 0h1305                        | Dec S Start    | S-curve deceleration start<br>point gradient  | 1-100 (%)                                     | 40               | X                          | 171  | O            | O      | O      | X           | X           |
| 06           | 0h1306                        | Dec S End      | S-curve deceleration end<br>point gradient    | 1-100 (%)                                     | 40               | X                          | 171  | O            | O      | O      | X           | X           |
| 07           | 0h1307                        | Start Mode     | Start mode                                    | 0 Acc   | 0:Acc            | X                          | 182  | O            | O      | O      | X           | X           |
|              |                               |                |   | 1 Dc-Start                                    |                  |                            |      |              |        |        |             |             |
| 08           | 0h1308                        | Stop Mode      | Stop mode                                     | 0 Dec   | 0:Dec            | X                          | 184  | O            | O      | O      | X           | X           |
|              |                               |                |   | 1 Dc-Brake                                    |                  |                            |      |              |        |        |             |             |
|              |                               |                |   | 2 Free-Run                                    |                  |                            |      |              |        |        |             |             |
|              |                               |                |   | 3 -Reserved-                                  |                  |                            |      |              |        |        |             |             |
|              |                               |                |   | 4 Power Braking                               |                  |                            |      |              |        |        |             |             |
| 09           | 0h1309                        | Run Prevent    | Selection of prohibited<br>rotation direction | 0 None  | 0:None           | X                          | 162  | O            | O      | O      | X           | X           |
|              |                               |                |   | 1 Forward Prev                                |                  |                            |      |              |        |        |             |             |
|              |                               |                |   | 2 Reverse Prev                                |                  |                            |      |              |        |        |             |             |
| 10           | 0h130A                        | Power-on Run   | Start with power on                           | 0 No  | 0:No             | O                          | 163  | O            | O      | O      | X           | X           |
|              |                               |                |   | 1 Yes   |                  |                            |      |              |        |        |             |             |
| 12<br>Note8) | 0h130C                        | Dc-Start Time  | Starting DC braking time                      | 0-60 (sec)                                    | 0.00             | X                          | 268  | O            | O      | O      | X           | X           |
| 13           | 0h130D                        | Dc Inj Level   | DC supply                                     | 0-200 (%)                                     | 50               | X                          | 268  | O            | O      | O      | X           | X           |
| 14<br>Note9) | 0h130E                        | Dc-Block Time  | Output blocking time before<br>DC braking     | 0-60 (sec)                                    | 0.10             | X                          | 184  | O            | O      | O      | X           | X           |
| 15           | 0h130F                        | Dc-Brake Time  | DC braking time                               | 0-60 (sec)                                    | 1.00             | X                          | 184  | O            | O      | O      | X           | X           |
| 16           | 0h1310                        | Dc-Brake Level | DC braking rate                               | 0-200 (%)                                     | 50               | X                          | 184  | O            | O      | O      | X           | X           |
| 17           | 0h1311                        | Dc-Brake Freq  | DC braking frequency                          | Starting frequency-60 (Hz)                    | 5.00             | X                          | 184  | O            | O      | O      | X           | X           |
| 20           | 0h1314                        | Acc Dwell Freq | Acceleration dwell<br>frequency               | Starting frequency<br>-maximum frequency (Hz) | 5.00             | X                          | 268  | O            | O      | O      | X           | X           |
| 21           | 0h1315                        | Acc Dwell Time | Acceleration dwell operation<br>time          | 0-60.0 (sec)                                  | 0.00             | X                          | 268  | O            | O      | O      | X           | X           |
| 22           | 0h1316                        | Dec Dwell Freq | Deceleration dwell<br>frequency               | Starting frequency<br>-maximum frequency (Hz) | 5.00             | X                          | 268  | O            | O      | O      | X           | X           |
| 23           | 0h1317                        | Dec Dwell Time | Deceleration dwell operation<br>time          | 0-60.0 (sec)                                  | 0.00             | X                          | 268  | O            | O      | O      | X           | X           |

\*  The grey cells indicate a hidden code which is only visible when setting a code.

Note 8) ADV-12 is displayed only when ADV-07 "Stop Mode" is set as "DC-Start".

Note 9) ADV-14-17 is displayed only when ADV-08 "Stop Mode" is set as "DC-Brake".

Expansion Function Group (PAR → ADV)

| No.           | Communication Address | LCD Display    | Name                              | Setting Range                                       | Initial Value | Shift in Operation | Page | Control Mode |       |       |           |           |
|---------------|-----------------------|----------------|-----------------------------------|---|---------------|--------------------|------|--------------|-------|-------|-----------|-----------|
|               |                       |                |                                   |   |               |                    |      | V / F        | S / L | V / C | S / L / T | V / C / T |
| 24            | 0h1318                | Freq Limit     | Frequency limit                   | 0 No<br>1 Yes                                       | 0:No          | X                  | 187  | O            | O     | O     | X         | X         |
| 25<br>Note10) | 0h1319                | Freq Limit Lo  | Frequency lower limit             | 0–upper limit (Hz)                                  | 0.50          | O                  | 187  | O            | O     | O     | X         | X         |
| 26            | 0h131A                | Freq Limit Hi  | Frequency upper limit             | 0.5–maximum frequency (Hz)                          | 60.00         | X                  | 187  | O            | O     | O     | X         | X         |
| 27            | 0h131B                | Jump Freq      | Frequency jump                    | 0 No<br>1 Yes                                       | 0:No          | X                  | 189  | O            | O     | O     | X         | X         |
| 28<br>Note11) | 0h131C                | Jump Lo 1      | Jump frequency lower limit 1      | 0–jump frequency upper limit 1 (Hz)                 | 10.00         | O                  | 189  | O            | O     | O     | X         | X         |
| 29            | 0h131D                | Jump Hi 1      | Jump frequency upper limit 1      | Jump frequency lower limit 1–maximum frequency (Hz) | 15.00         | O                  | 189  | O            | O     | O     | X         | X         |
| 30            | 0h131E                | Jump Lo 2      | Jump frequency lower limit 2      | 0–jump frequency upper limit 2 (Hz)                 | 20.00         | O                  | 189  | O            | O     | O     | X         | X         |
| 31            | 0h131F                | Jump Hi 2      | Jump frequency upper limit 2      | Jump frequency lower limit 2–maximum frequency (Hz) | 25.00         | O                  | 189  | O            | O     | O     | X         | X         |
| 32            | 0h1320                | Jump Lo 3      | Jump frequency lower limit 3      | 0–jump frequency upper limit 3 (Hz)                 | 30.00         | O                  | 189  | O            | O     | O     | X         | X         |
| 33            | 0h1321                | Jump Hi 3      | Jump frequency upper limit 3      | Jump frequency lower limit 3–maximum frequency (Hz) | 35.00         | O                  | 189  | O            | O     | O     | X         | X         |
| 34<br>Note10) | 0h1322                | Jog Freq Limit | Jog frequency limit               | 0 No<br>1 Yes                                       | 1:Yes         | O                  | 187  | O            | O     | O     | X         | X         |
| 41<br>Note12) | 0h1329                | BR Rls Curr    | Brake release current             | 0–180.0 (%)   | 50.0          | O                  | 268  | O            | O     | O     | X         | X         |
| 42            | 0h132A                | BR Rls Dly     | Brake release delay time          | 0–10.00 (sec)                                       | 1.00          | X                  | 268  | O            | O     | O     | X         | X         |
| 44            | 0h132C                | BR Rls Fwd Fr  | Brake release forward frequency   | 0–400 (Hz)  | 1.00          | X                  | 268  | O            | O     | O     | X         | X         |
| 45            | 0h132D                | BR Rls Rev Fr  | Brake release reverse frequency   | 0–400 (Hz)  | 1.00          | X                  | 268  | O            | O     | O     | X         | X         |
| 46            | 0h132E                | BR Eng Dly     | Brake engage delay time           | 0–10 (sec)  | 1.00          | X                  | 268  | O            | O     | O     | X         | X         |
| 47            | 0h132F                | BR Eng Fr      | Brake engage frequency            | 0–400 (Hz)  | 2.00          | X                  | 268  | O            | O     | O     | X         | X         |
| 50            | 0h1332                | E-Save Mode    | Energy saving operation           | 0 None<br>1 Manual<br>2 Auto                        | 0:None        | X                  | 242  | O            | O     | X     | X         | X         |
| 51<br>Note13) | 0h1333                | Energy Save    | Energy saving amount              | 0–30 (%)  | 0             | O                  | 242  | O            | O     | O     | X         | X         |
| 60            | 0h133C                | Xcel Change Fr | Acc/dec time transition frequency | 0–maximum frequency (Hz)                            | 0.00          | X                  | 169  | O            | O     | O     | X         | X         |

\*  The grey cells indicate a hidden code which is only visible when setting a code.

Note 10) ADV-25–26, 34 is displayed only when ADV-24 (Freq Limit) is set as “Freq Limit”.

Note 11) ADV-28–33 is displayed only when ADV-27 (Jump Freq) is set as “Yes”.

Note 12) ADV-41–47 is displayed only when a code of OUT-31–33 is set as “BR Control”.

Note 13) ADV-51 is displayed only when ADV-50 (E-Save Mode) is set as a value other than “None”.

## Expansion Function Group (PAR → ADV)

| No.           | Communication Address | LCD Display     | Name   | Setting Range                             | Initial Value | Shift in Operation | Page | Control Mode |     |     |       |       |   |
|---------------|-----------------------|-----------------|--|---|---------------|--------------------|------|--------------|-----|-----|-------|-------|---|
|               |                       |                 |  |   |               |                    |      | V / F        | S L | V C | S L T | V C T |   |
| 61            | -                     | Load Spd Gain   | Revolution display gain  | 0.1-6000.0 (%)                            | 100.0         | O                  | 287  | O            | O   | O   | X     | X     |   |
| 62            | -                     | Load Spd Scale  | Revolution display scale   | 0   | x 1           | 0:x 1              | O    | 287          | O   | O   | O     | X     | X |
|               |                       |                 |  | 1   | x 0.1         |                    |      |              |     |     |       |       |   |
|               |                       |                 |  | 2   | x 0.01        |                    |      |              |     |     |       |       |   |
|               |                       |                 |  | 3   | x 0.001       |                    |      |              |     |     |       |       |   |
|               |                       |                 |  | 4   | x 0.0001      |                    |      |              |     |     |       |       |   |
| 63            | 0h133F                | Load Spd Unit   | Revolution display unit  | 0   | Rpm           | 0:rpm              | O    | 287          | O   | O   | O     | O     | O |
|               |                       |                 |  | 1   | Mpm           |                    |      |              |     |     |       |       |   |
| 64            | 0h1340                | FAN Control     | Cooling fan control  | 0   | During Run    | 0:During Run       | O    | 254          | O   | O   | O     | X     | X |
|               |                       |                 |  | 1   | Always ON     |                    |      |              |     |     |       |       |   |
|               |                       |                 |  | 2   | Temp Control  |                    |      |              |     |     |       |       |   |
| 65            | 0h1341                | U/D Save Mode   | Up/down operation frequency save                                   | 0   | No            | 0:No               | O    | 202          | O   | O   | O     | X     | X |
|               |                       |                 |  | 1   | Yes           |                    |      |              |     |     |       |       |   |
| 66            | 0h1342                | On/Off Ctrl Src | Output contact On/Off control options                              | 0   | None          | 0:None             | X    | 269          | O   | O   | O     | O     | O |
|               |                       |                 |  | 1   | V1            |                    |      |              |     |     |       |       |   |
|               |                       |                 |  | 2   | I1            |                    |      |              |     |     |       |       |   |
|               |                       |                 |  | 3   | V2            |                    |      |              |     |     |       |       |   |
|               |                       |                 |  | 4   | I2            |                    |      |              |     |     |       |       |   |
| 67            | 0h1343                | On-C Level      | Output contact point On level                                      | 10–100 (%)                                | 90.00         | X                  | 269  | O            | O   | O   | O     | O     |   |
| 68            | 0h1344                | Off-C Level     | Output contact point Off level                                     | -100.00–output contact point On level (%) | 10.00         | X                  | 269  | O            | O   | O   | O     | O     |   |
| 70            | 0h1346                | Run En Mode     | Safe operation selection   | 0   | Always Enable | 0:Always Enable    | X    | 207          | O   | O   | O     | O     | O |
|               |                       |                 |  | 1   | DI Dependent  |                    |      |              |     |     |       |       |   |
| 71<br>Note14) | 0h1347                | Run Dis Stop    | Safe operation stop method   | 0   | Free-Run      | 0:Free-Run         | X    | 207          | O   | O   | O     | O     | O |
|               |                       |                 |  | 1   | Q-Stop        |                    |      |              |     |     |       |       |   |
|               |                       |                 |  | 2   | Q-Stop Resume |                    |      |              |     |     |       |       |   |
| 72            | 0h1348                | Q-Stop Time     | Safe operation deceleration time                                   | 0–600.0 (sec)                             | 5.0           | O                  | 207  | O            | O   | O   | O     | O     |   |
| 73            | 0h1349                | RegenAvd Mode   | Regeneration evasion mode  | Bit                                       | 001-111       | 001                | X    | 278          | O   | O   | O     | O     | O |
|               |                       |                 |  | 0   | Steady        |                    |      |              |     |     |       |       |   |
|               |                       |                 |  | 1   | Accelerating  |                    |      |              |     |     |       |       |   |
|               |                       |                 |  | 2   | Decelerating  |                    |      |              |     |     |       |       |   |
| 74            | 0h134A                | RegenAvd Sel    | Selection of regeneration evasion function for press               | 0   | No            | No                 | X    | 278          | O   | O   | O     | O     | O |
|               |                       |                 |  | 1   | Yes           |                    |      |              |     |     |       |       |   |
| 75            | 0h134B                | RegenAvd Level  | Operational voltage level of regeneration evasion motion for press | 200 V: 300–400                            | 350 V         | X                  | 278  | O            | O   | O   | X     | X     |   |
|               |                       |                 |  | 400 V: 600–800                            | 700 V         |                    |      |              |     |     |       |       |   |
| 76<br>Note15) | 0h134C                | CompFreq Limit  | Compensation frequency limit of regeneration for evasion for press | 0–10.00 Hz                                | 1.00 (Hz)     | X                  | 278  | O            | O   | O   | X     | X     |   |
| 77            | 0h134D                | RegenAvd Pgain  | Regeneration evasion for press P gain                              | 0–100.0 %                                 | 50.0 (%)      | O                  | 278  | O            | O   | O   | X     | X     |   |



## Table of Functions

| No.           | Communication Address | LCD Display    | Name  | Setting Range                                 | Initial Value      | Shift in Operation | Page | Control Mode |     |     |       |       |
|---------------|-----------------------|----------------|---|---|--------------------|--------------------|------|--------------|-----|-----|-------|-------|
|               |                       |                |   |   |                    |                    |      | V / F        | S L | V C | S L T | V C T |
| 78            | 0h134E                | RegenAvd lgain | Regeneration evasion for press l gain       | 20–30000 (ms)                                 | 500 (ms)           | O                  | 278  | O            | O   | O   | X     | X     |
| 79            | 0h134F                | DB Turn On Lev | DB unit operating voltage                   | 200 V : 350–400 (V)<br>400 V : 600–800 (V)    | 390 (V)<br>780 (V) | X                  | 282  | O            | O   | O   | O     | O     |
| 80            | 0h1350                | Fire Mode Sel  | Select fire mode                            | 0 None<br>1 Fire Mode<br>2 Fire Test          | 0:None             | X                  | 280  | O            | O   | O   | X     | X     |
| 81<br>Note16) | 0h1351                | Fire Mode Freq | Fire mode frequency                         | 0-maximum frequency (Hz)                      | 60.00              | X                  | 280  | O            | O   | O   | X     | X     |
| 82            | 0h1352                | Fireq Mode Dir | Fire mode operating direction               | 0 Forward<br>1 Reverse                        | 0:Forward          | X                  | 280  | O            | O   | O   | X     | X     |
| 83            | -                     | Fire Mode Cnt  | Fire mode counter                           | 0-99  | 0                  | X                  | 280  | O            | O   | O   | X     | X     |
| 85            | 0h1355                | U/D Mode Sel   | U/D Mode                                    | 0 U/D Normal<br>1 U/D Step<br>2 U/D Step+Norm | 0:U/D Normal       | X                  | 202  | O            | O   | O   | X     | X     |
| 86<br>Note17) | 0h1356                | U/D Step Freq  | U/D step frequency                          | 0-maximum frequency [Hz]                      | 0.00               | O                  | 202  | O            | O   | O   | X     | X     |
| 87            | 0h1357                | OVM Mode Sel   | Voltage Drop compensation                   | 0 No<br>1 Yes                                 | 0:No               | X                  | 298  | O            | X   | O   | O     | O     |
| 91            | 0h135B                | Auxiliary OPT  | AUX Power Option Sel                        | 0 No<br>1 Yes                                 | 0:No               | X                  | -    | O            | O   | O   | O     | O     |
| 92<br>Note18) | 0h135C                | SlipGain Mot-H | slip compensation offsetting gain H         | 0~200[%]                                      | 50                 | O                  | 210  | O            | X   | X   | X     | X     |
| 93            | 0h135D                | SlipGain Gen-H | slip compensation regenerative gain H       | 0~200[%]                                      | 50                 | O                  | 210  | O            | X   | X   | X     | X     |
| 94            | 0h135E                | SlipGain Mot-L | slip compensation offsetting gain L         | 0~200[%]                                      | 50                 | O                  | 210  | O            | X   | X   | X     | X     |
| 95            | 0h135F                | SlipGain Gen-L | slip compensation regenerative gain L       | 0~200[%]                                      | 50                 | O                  | 210  | O            | X   | X   | X     | X     |
| 96            | 0h1360                | Slip Filter    | slip compensation filter                    | 0~10000[msec]                                 | 300                | O                  | 210  | O            | X   | X   | X     | X     |
| 97            | 0h1361                | Slip Comp Freq | slip compensation frequency                 | 0~60.00[Hz]                                   | 5.00               | O                  | 210  | O            | X   | X   | X     | X     |
| 98            | 0h1362                | Slip Gain Freq | slip compensation gain switchover frequency | 0~20.00[Hz]                                   | 9.00               | O                  | 210  | O            | X   | X   | X     | X     |

\*  The grey cells indicate a hidden code which is only visible when setting a code.

Note 14) ADV-71–72 is displayed only when ADV-70 (Run En Mode) is set as “DI Dependent”.

ADV-73 is displayed only when ADV-74 (RegenAvd Sel) is set as “Yes”.

Note 15) ADV-76–78 is displayed only when ADV-75 (RegenAvd Sel) is set as “Yes”.

Note 16) ADV-81–83 displayed only when ADV-80 (Fire Mode Sel) is set as “Fire Mode” or “Fire Test”.

Note 17) ADV-86 is displayed when ADV-85 (U/D Mode Sel) is not set to “U/D Normal”.

Note 18) ADV-92–98 is displayed only when DRV-09 (Control Mode) is set as “Slip Compen”

## 13.4 Parameter Mode – Control Function Group (→CON)

### Control Function Group (PAR → CON)

| No.           | Communi-<br>cation<br>Address | LCD Display    | Name   | Setting Range                     | Initial Value               | Shift in<br>Opera-<br>tion | Page | Control Mode |        |        |             |             |
|---------------|-------------------------------|----------------|--|-----------------------------------|-----------------------------|----------------------------|------|--------------|--------|--------|-------------|-------------|
|               |                               |                |  |                                   |                             |                            |      | V<br>/<br>F  | S<br>L | V<br>C | S<br>L<br>T | V<br>C<br>T |
| 00            | -                             | Jump Code      | Jump code                                      | 0-99                              | 51                          | O                          |      | O            | O      | O      | O           | O           |
| 04            | 0h1404                        | Carrier Freq   | Carrier frequency                              | Below 22 kW                       | 0.7-15 (kHz)                | 5.0                        | O    | 248          | O      | O      | O           | O           |
|               |                               |                |  | 30-45 kW                          | 0.7-10 (kHz)                | 5.0                        |      |              |        |        |             |             |
|               |                               |                |  | 55-75 kW                          | 0.7-7 (kHz)                 | 5.0                        |      |              |        |        |             |             |
|               |                               |                |  | 90-110 kW                         | 0.7-6 (kHz)                 | 3.0                        |      |              |        |        |             |             |
|               |                               |                |  | 132-160 kW                        | 0.7-5 (kHz)                 | 3.0                        |      |              |        |        |             |             |
|               |                               |                |  | 185-220 kW                        | 0.7-3 (kHz)                 | 2.0                        |      |              |        |        |             |             |
|               |                               |                |  | 280-375 kW                        | 0.7-2 (kHz)                 | 2.0                        |      |              |        |        |             |             |
| 05            | 0h1405                        | PWM Mode       | Switching mode                                 | 0 Normal PWM<br>1 Low leakage PWM | 0:Normal PWM                | X                          | 248  | O            | O      | O      | O           | O           |
| 09            | 0h1409                        | PreExTime      | Initial excitation time                        | 0-60 (sec)                        | 1.00                        | X                          | 232  | X            | X      | O      | O           | O           |
| 10            | 0h140A                        | Flux Force     | Initial excitation power supply                | 100-500 (%)                       | 100.0                       | X                          | 232  | X            | X      | O      | O           | O           |
| 11            | 0h140B                        | Hold Time      | Continued operation duration                   | 0-60 (sec)                        | Dependent on control mode   | X                          | 232  | X            | X      | O      | X           | X           |
| 12            | 0h140C                        | ASR P Gain 1   | Speed controller proportional gain 1           | 10-500 (%)                        | 50.0                        | O                          | 232  | X            | X      | O      | X           | X           |
| 13            | 0h140D                        | ASR I Gain 1   | Speed controller integral gain 1               | 10-9999 (msec)                    | 300                         | O                          | 232  | X            | X      | O      | X           | X           |
| 15            | 0h140F                        | ASR P Gain 2   | Speed controller proportional gain 2           | 10-500 (%)                        | 50.0                        | O                          | 232  | X            | X      | O      | X           | X           |
| 16            | 0h1410                        | ASR I Gain 2   | Speed controller integral gain 2               | 10-9999 (ms)                      | 300                         | O                          | 232  | X            | X      | O      | X           | X           |
| 18            | 0h1412                        | Gain SW Freq   | Gain exchange frequency                        | 0-120 (Hz)                        | 0.00                        | X                          | 232  | X            | X      | O      | X           | X           |
| 19            | 0h1413                        | Gain Sw Delay  | Gain exchange time                             | 0-100 (sec)                       | 0.10                        | X                          | 232  | X            | X      | O      | X           | X           |
| 20            | 0h1414                        | SL2 G View Sel | Sensorless 2nd gain display setting            | 0 No                              | 0:No                        | O                          | 228  | X            | X      | X      | X           | X           |
|               |                               |                |  | 1 Yes                             |                             |                            |      |              |        |        |             |             |
| 21            | 0h1415                        | ASR-SL P Gain1 | Sensorless speed controller proportional gain1 | 0-5000 (%)                        | Dependent on motor capacity | O                          | 228  | X            | O      | X      | X           | X           |
| 22            | 0h1416                        | ASR-SL I Gain1 | Sensorless speed controller integral gain 1    | 10-9999 (ms)                      | Dependent on motor capacity | O                          | 228  | X            | O      | X      | X           | X           |
| 23<br>Note17) | 0h1417                        | ASR-SL P Gain2 | Senseless speed controller proportional gain 2 | 1.0-1000.0 (%)                    | Dependent on motor capacity | O                          | 228  | X            | X      | X      | X           | X           |
| 24            | 0h1418                        | ASR-SL I       | Sensorless2                                    | 1.0-1000.0 (%)                    | Dependent                   | O                          | 228  | X            | X      | X      | X           | X           |

## Table of Functions

| No. | Communication Address | LCD Display    | Name  | Setting Range | Initial Value               | Shift in Operation | Page | Control Mode |     |     |       |       |   |   |
|-----|-----------------------|----------------|---|---------------|-----------------------------|--------------------|------|--------------|-----|-----|-------|-------|---|---|
|     |                       |                |   |               |                             |                    |      | V / F        | S L | V C | S L T | V C T |   |   |
|     |                       | Gain2          | speed controller integral gain 2                |               | on motor capacity           |                    |      |              |     |     |       |       |   |   |
| 26  | 0h141A                | Observer Gain1 | Sensorless2 measurer gain 1                     | 0-30000       | 10500                       | O                  | 228  | X            | X   | X   | X     | X     | X | X |
| 27  | 0h141B                | Observer Gain2 | Sensorless2 measurer gain 2                     | 1-1000 (%)    | 100.0                       | O                  | 228  | X            | X   | X   | X     | X     | X | X |
| 28  | 0h141C                | Observer Gain3 | Sensorless2 measurer gain 3                     | 0-30000       | 13000                       | O                  | 228  | X            | X   | X   | X     | X     | X | X |
| 29  | 0h141D                | S-Est P Gain1  | Sensorless2 speed estimator proportional gain 1 | 0-30000       | Dependent on motor capacity | O                  | 228  | X            | X   | X   | X     | X     | X | X |
| 30  | 0h141E                | S-Est I Gain1  | Sensorless2 speed estimator integral gain 1     | 0-30000       | Dependent on motor capacity | O                  | 228  | X            | X   | X   | X     | X     | X | X |

\*  The grey cells indicate a hidden code which is only visible when setting a code.

Note 17) CON-23-28, 31-32 are displayed only when DRV-09 (Control Mode) is "Sensorless2" and CON-20 (SL2 G View Sel) is set as "Yes".

Control Function Group (PAR → CON)

| No.           | Communication Address | LCD Display    | Name  | Setting Range  | Initial Value               | Shift in Operation | Page | Control Mode |     |     |       |       |   |
|---------------|-----------------------|----------------|---|----------------|-----------------------------|--------------------|------|--------------|-----|-----|-------|-------|---|
|               |                       |                |   |                |                             |                    |      | V/F          | S/L | V/C | S/L/T | V/C/T |   |
| 31            | 0h141F                | S-Est P Gain2  | Sensorless2 speed estimator proportional gain 2     | 1.0~1000.0 (%) | Dependent on motor capacity | O                  | 228  | X            | X   | X   | X     | X     |   |
| 32            | 0h1420                | S-Est I Gain2  | Sensorless2 speed estimator integral gain 2         | 1.0~1000.0 (%) | Dependent on motor capacity | O                  | 228  | X            | X   | X   | X     | X     |   |
| 34            | 0h1422                | SL2 OVM Perc   | Sensorless2 overvoltage modulation range adjustment | 100~180 (%)    | 120                         | X                  | 230  | X            | O   | X   | X     | X     |   |
| 35            | 0h1423                | SL2 L-ExcitLmt | Magnetic flux current minimum ratio                 | 3~100[%]       | 10                          | O                  | 236  | X            | X   | X   | O     | X     |   |
| 45<br>Note18) | 0h142D                | PG P Gain      | PG operation proportional gain                      | 0~9999         | 3000                        | O                  | 225  | O            | X   | X   | X     | X     |   |
| 46            | 0h142E                | PG I Gain      | PG operation integral gain                          | 0~9999         | 50                          | O                  | 225  | O            | X   | X   | X     | X     |   |
| 47            | 0h142F                | PG Slip Max%   | PG operation maximum slip                           | 0~200          | 100                         | X                  | 225  | O            | X   | X   | X     | X     |   |
| 48            | 0h1430                | ACR P Gain     | Current controller P gain                           | 0~10000        | 1200                        | O                  | 228  | X            | O   | O   | O     | O     |   |
| 49            | 0h1431                | ACR I Gain     | Current controller I gain                           | 0~10000        | 120                         | O                  | 228  | X            | O   | O   | O     | O     |   |
| 51            | 0h1433                | ASR Ref LPF    | Speed controller reference filter                   | 0~20000 (ms)   | 0                           | X                  | 232  | X            | O   | O   | X     | X     |   |
| 52            | 0h1434                | Torque Out LPF | Torque controller output filter                     | 0~2000 (ms)    | 0                           | X                  | 232  | X            | X   | X   | O     | O     |   |
| 53            | 0h1435                | Torque Lmt Src | Torque limit setting options                        | 0              | Keypad-1                    | 0:Keypad-1         | X    | 232          | X   | X   | X     | O     | O |
|               |                       |                |   | 1              | Keypad-2                    |                    |      |              |     |     |       |       |   |
|               |                       |                |   | 2              | V1                          |                    |      |              |     |     |       |       |   |
|               |                       |                |   | 3              | I1                          |                    |      |              |     |     |       |       |   |
|               |                       |                |   | 4              | V2                          |                    |      |              |     |     |       |       |   |
|               |                       |                |   | 5              | I2                          |                    |      |              |     |     |       |       |   |
|               |                       |                |   | 6              | Int 485                     |                    |      |              |     |     |       |       |   |
|               |                       |                |   | 7              | Encoder                     |                    |      |              |     |     |       |       |   |
|               |                       |                |   | 8              | FieldBus                    |                    |      |              |     |     |       |       |   |
|               |                       |                |   | 9              | PLC                         |                    |      |              |     |     |       |       |   |
|               |                       |                |   | 10             | Synchro                     |                    |      |              |     |     |       |       |   |
| 11            | Binary Type           |                |   |                |                             |                    |      |              |     |     |       |       |   |
| 54<br>Note19) | 0h1436                | FWD +Trq Lmt   | Forward offsetting torque limit                     | 0~200 (%)      | 180.0                       | O                  | 232  | X            | X   | X   | O     | O     |   |
| 55            | 0h1437                | FWD -Trq Lmt   | Forward offsetting torque limit                     | 0~200 (%)      | 180.0                       | O                  | 232  | X            | X   | X   | O     | O     |   |
| 56            | 0h1438                | REV +Trq Lmt   | Reverse regenerative torque limit                   | 0~200 (%)      | 180.0                       | O                  | 232  | X            | X   | X   | O     | O     |   |
| 57            | 0h1439                | REV -Trq Lmt   | Reverse regenerative torque limit                   | 0~200 (%)      | 180.0                       | O                  | 232  | X            | X   | X   | O     | O     |   |

\*  The grey cells indicate a hidden code which is only visible when setting a code.

Note 18) CON-45~47 are displayed when the Encoder module is installed and Control mode is set as "V/F PG".

Note 19) CON-54~57 are displayed only when DRV-09 (Control Mode) is set as "Sensorless-1, 2" or "Vector".

In addition, the initial value of the torque limit is changed to 150% when the ADV-74 RegenAvd Level function is set.

Control Function Group (PAR → CON)

| No.           | Communi-<br>cation<br>Address | LCD Display       | Name   | Setting Range               | Initial Value | Shift in<br>Operation | Page | 1)Control<br>Mode |        |        |             |             |   |
|---------------|-------------------------------|-------------------|--|-----------------------------|---------------|-----------------------|------|-------------------|--------|--------|-------------|-------------|---|
|               |                               |                   |  |                             |               |                       |      | V<br>/<br>F       | S<br>L | V<br>C | S<br>L<br>T | V<br>C<br>T |   |
| 58            | 0h143A                        | Trq Bias Src      | Torque bias<br>setting options                           | 0                           | Keypad-1      | 0:Keypad-1            | X    | 232               | X      | X      | O           | X           | X |
|               |                               |                   |  | 1                           | Keypad-2      |                       |      |                   |        |        |             |             |   |
|               |                               |                   |  | 2                           | V1            |                       |      |                   |        |        |             |             |   |
|               |                               |                   |  | 3                           | I1            |                       |      |                   |        |        |             |             |   |
|               |                               |                   |  | 4                           | V2            |                       |      |                   |        |        |             |             |   |
|               |                               |                   |  | 5                           | I2            |                       |      |                   |        |        |             |             |   |
|               |                               |                   |  | 6                           | Int 485       |                       |      |                   |        |        |             |             |   |
|               |                               |                   |  | 7                           | FieldBus      |                       |      |                   |        |        |             |             |   |
|               |                               |                   |  | 8                           | PLC           |                       |      |                   |        |        |             |             |   |
| 59            | 0h143B                        | Torque Bias       | Torque bias  | -120~120 (%)                | 0.0           | O                     | 232  | X                 | X      | O      | X           | X           |   |
| 60            | 0h143C                        | Torque<br>Bias FF | Torque bias<br>compensation                              | 0~100 (%)                   | 0.0           | O                     | 232  | X                 | X      | O      | X           | X           |   |
| 62            | 0h143E                        | Speed<br>Lmt Src  | Speed limit setting<br>options                           | 0                           | Keypad-1      | 0:Keypad-1            | O    | 236               | X      | X      | X           | X           | O |
|               |                               |                   |  | 1                           | Keypad-2      |                       |      |                   |        |        |             |             |   |
|               |                               |                   |  | 2                           | V1            |                       |      |                   |        |        |             |             |   |
|               |                               |                   |  | 3                           | I1            |                       |      |                   |        |        |             |             |   |
|               |                               |                   |  | 4                           | V2            |                       |      |                   |        |        |             |             |   |
|               |                               |                   |  | 5                           | I2            |                       |      |                   |        |        |             |             |   |
|               |                               |                   |  | 6                           | Int 485       |                       |      |                   |        |        |             |             |   |
|               |                               |                   |  | 7                           | FieldBus      |                       |      |                   |        |        |             |             |   |
|               |                               |                   |  | 8                           | PLC           |                       |      |                   |        |        |             |             |   |
| 63            | 0h143F                        | FWD Speed<br>Lmt  | Forward speed limit                                      | 0~maximum<br>frequency (Hz) | 60.00         | O                     | 236  | X                 | X      | X      | X           | O           |   |
| 64            | 0h1440                        | REV Speed<br>Lmt  | Reverse speed limit                                      | 0~maximum<br>frequency (Hz) | 60.00         | O                     | 236  | X                 | X      | X      | X           | O           |   |
| 65            | 0h1441                        | Speed Lmt<br>Gain | Speed limit operation<br>gain                            | 100~5000 (%)                | 500           | O                     | 236  | X                 | X      | X      | X           | O           |   |
| 66            | 0h1442                        | Droop Perc        | Droop operation amount                                   | 0~100 (%)                   | 0.0           | O                     | 238  | X                 | X      | X      | X           | O           |   |
| 67<br>Note20) | 0h1443                        | Droop St Trq      | Droop start torque                                       | 0~100 (%)                   | 100.0         | O                     | 238  | X                 | X      | X      | X           | O           |   |
| 68            | 0h1444                        | SPD/TRQAc<br>c T  | Torque mode<br>→speed mode exchange<br>acceleration time | 0~600 (sec)                 | 20.0          | O                     | 238  | X                 | X      | X      | X           | O           |   |
| 69            | 0h1445                        | SPD/TRQAc<br>c T  | Torque mode<br>→speed mode exchange<br>deceleration time | 0~600 (sec)                 | 30.0          | O                     | 238  | X                 | X      | X      | X           | O           |   |

\*  The grey cells indicate a hidden code which is only visible when setting a code.

Note 20) CON-67 is displayed only when the Encoder option module is installed.

## Control Function Group (PAR → CON)

| No.           | Communication Address | LCD Display    | Name   | Setting Range                                | Initial Value                            | Shift in Operation | Page | 1)Control Mode |     |     |       |       |
|---------------|-----------------------|----------------|--|--|--|--------------------|------|----------------|-----|-----|-------|-------|
|               |                       |                |  |  |  |                    |      | V / F          | S L | V C | S L T | V C T |
| 70            | 0h1446                | SS Mode        | Speed search mode selection                    | 0   Flying Start - 1<br>1   Flying Start - 2 | 0  | X                  | 244  | O              | O   | O   | X     | X     |
| 71            | 0h1447                | Speed Search   | Speed search operation selection               | Bit 0000-1111                                | 0000                                     | X                  | 244  | O              | O   | O   | X     | X     |
|               |                       |                |  | 1   Speed search selection on acceleration   |  |                    |      |                |     |     |       |       |
|               |                       |                |  | 2   Restart after trips                      |  |                    |      |                |     |     |       |       |
|               |                       |                |  | 3   Restart after instantaneous interruption |  |                    |      |                |     |     |       |       |
|               |                       |                |  | 4   Start immediately after power On         |  |                    |      |                |     |     |       |       |
| 72<br>Note21) | 0h1448                | SS Sup-Current | Speed search standard current                  | 80-200 (%)                                   | Below 75 kW<br>150<br>Above 90 kW<br>100 | O                  | 244  | O              | O   | X   | X     | X     |
| 73            | 0h1449                | SS P-Gain      | Speed search proportional gain                 | 0-9999                                       | 100                                      | O                  | 244  | O              | O   | X   | X     | X     |
| 74            | 0h144A                | SS I-Gain      | Speed search integral gain                     | 0-9999                                       | 200                                      | O                  | 244  | O              | O   | X   | X     | X     |
| 75            | 0h144B                | SS Block Time  | Output block time before speed search          | 0-60 (sec)                                   | 1.0                                      | X                  | 244  | O              | O   | X   | X     | X     |
| 77            | 0h144D                | KEB Select     | Energy buffering selection                     | 0   None                                     | 0:None                                   | X                  | 239  | O              | O   | O   | X     | X     |
|               |                       |                |  | 1   KEB-1                                    |  |                    |      |                |     |     |       |       |
|               |                       |                |  | 2   KEB-2                                    |  |                    |      |                |     |     |       |       |
| 78<br>Note21) | 0h144E                | KEB Start Lev  | Energy buffering start level                   | 110-200 (%)                                  | 130.0                                    | X                  | 239  | O              | O   | O   | X     | X     |
| 79            | 0h144F                | KEB Stop Lev   | Energy buffering stop level                    | 130-210 (%)                                  | 135.0                                    | X                  | 239  | O              | O   | O   | X     | X     |
| 80            | 0h1450                | KEB Gain       | Energy buffering gain                          | 1-2000                                       | 1000                                     | O                  | 239  | O              | O   | O   | X     | X     |
| 82<br>Note22) | 0h1452                | ZSD Frequency  | Permanent detection frequency                  | 0-10 (Hz)                                    | 2.00                                     | O                  | 302  | X              | X   | O   | X     | O     |
| 83            | 0h1453                | ZSD Band       | Permanent detection frequency band             | 0-2 (Hz)                                     | 1.00                                     | O                  | 302  | X              | X   | O   | X     | O     |
| 86<br>Note23) | 0h1456                | KEB P Gain     | Energy buffering P gain                        | 0-20000                                      | 1500                                     | O                  | 239  | O              | O   | O   | X     | X     |
| 87            | 0h1457                | KEB I Gain     | Energy buffering I gain                        | 1-20000                                      | 500                                      | O                  | 239  | O              | O   | O   | X     | X     |
| 88            | 0h1458                | KEB Slip Gain  | Energy buffering slip gain                     | 0-2000.0 (%)                                 | 30.0                                     | O                  | 239  | O              | O   | O   | X     | X     |
| 89            | 0h1459                | KEB Acc Time   | Energy buffering acceleration time             | 0-600 (sec)                                  | 10.0                                     | O                  | 239  | O              | O   | O   | X     | X     |
| 90            | 0h145A                | New AHR Sel    | Select function for preventing current hunting | 0   No                                       | 0:No                                     | O                  | 279  | O              | X   | X   | X     | X     |
|               |                       |                |  | 1   Yes                                      |  |                    |      |                |     |     |       |       |
| 91            | 0h145B                | AHR P-Gain     | Gain from current                              | 0-32767                                      | 1000                                     | X                  | 279  | O              | X   | X   | X     | X     |

## Table of Functions

| No. | Communication Address | LCD Display | Name               | Setting Range | Initial Value | Shift in Operation | Page | 1)Control Mode |     |     |       |       |  |
|-----|-----------------------|-------------|--------------------|---------------|---------------|--------------------|------|----------------|-----|-----|-------|-------|--|
|     |                       |             |                    |               |               |                    |      | V / F          | S L | V C | S L T | V C T |  |
|     |                       |             | hunting prevention |               |               |                    |      |                |     |     |       |       |  |

\*  The grey cells indicate a hidden code which is only visible when setting a code.

Note 21) CON-72-75 are displayed only when CON-71,77 is set as a bit or other than "None".

Note 22) CON-82-83 are displayed only when DRV-09 (Control Mode) is set as "Vector".

Note 23) CON-78-79,86-89 are displayed only when CON-77 (KEB Select) is set as "KEB-1" or "KEB-2"

Note 24) CON-91 is displayed only when CON-90 (New AHR Sel) is set as "Yes".

## 13.5 Parameter Mode – Input Terminal Block Function Group (→IN)

### Input Terminal Block Function Group (PAR → IN)

| No.                          | Communication Address | LCD Display    | Name                              | Setting Range                          | Initial Value | Shift in Operation | Page | Control Mode |     |     |       |       |
|------------------------------|-----------------------|----------------|-----------------------------------|--|---------------|--------------------|------|--------------|-----|-----|-------|-------|
|                              |                       |                |                                   |  |               |                    |      | V / F        | S L | V C | S L T | V C T |
| 00                           | -                     | Jump Code      | Jump code                         | 0-99                                   | 65            | O                  | -    | O            | O   | O   | O     | O     |
| 01                           | 0h1501                | Freq at 100%   | Frequency at maximum analog input | Start frequency-maximum frequency (Hz) | 60.00         | O                  | 139  | O            | O   | O   | X     | X     |
| 02                           | 0h1502                | Torque at 100% | Torque at maximum analog input    | 0-200 (%)                              | 100.0         | O                  | 139  | X            | X   | O   | O     | O     |
| 05                           | 0h1505                | V1 Monitor(V)  | V1 input voltage display          | 0-10 (V)                               | 0.00          | O                  | 139  | O            | O   | O   | O     | O     |
| 06                           | 0h1506                | V1 Polarity    | V1 input polarity selection       | 0 Unipolar<br>1 Bipolar                | 0: Unipolar   | O                  | 139  | O            | O   | O   | O     | O     |
| 07                           | 0h1507                | V1 Filter      | V1 input filter time constant     | 0-10000 (ms)                           | 10            | O                  | 139  | O            | O   | O   | O     | O     |
| 08                           | 0h1508                | V1 Volt x1     | V1 minimum input voltage          | 0-10 (V)                               | 0.00          | O                  | 139  | O            | O   | O   | O     | O     |
| 09                           | 0h1509                | V1 Perc y1     | V1 minimum output voltage (%)     | 0-100 (%)                              | 0.00          | O                  | 139  | O            | O   | O   | O     | O     |
| 10                           | 0h150A                | V1 Volt x2     | V1 maximum input voltage          | 0-10 (V)                               | 10.00         | O                  | 139  | O            | O   | O   | O     | O     |
| 11                           | 0h150B                | V1 Perc y2     | V1 maximum output voltage (%)     | 0-100 (%)                              | 100.00        | O                  | 139  | O            | O   | O   | O     | O     |
| 12<br><small>Note24)</small> | 0h150C                | V1 (-)Volt x1' | V1 (-) minimum input voltage      | -10-0 (V)                              | 0.00          | O                  | 143  | O            | O   | O   | O     | O     |
| 13                           | 0h150D                | V1(-)Perc y1'  | V1 (-) minimum output voltage (%) | -100-0 (%)                             | 0.00          | O                  | 143  | O            | O   | O   | O     | O     |
| 14                           | 0h150E                | V1(-)Volt x2'  | V1 (-) maximum input voltage      | -10-0 (V)                              | -10.00        | O                  | 143  | O            | O   | O   | O     | O     |
| 15                           | 0h150F                | V1(-)Perc y2'  | V1 (-) maximum output voltage (%) | -100-0 (%)                             | -100.00       | O                  | 143  | O            | O   | O   | O     | O     |
| 16                           | 0h1510                | V1 Inverting   | Rotation direction change         | 0 No<br>1 Yes                          | 0: No         | O                  | 139  | O            | O   | O   | O     | O     |
| 17                           | 0h1511                | V1 Quantizing  | V1 quantization change            | 0.04-10 (%)                            | 0.04          | O                  | 139  | O            | O   | O   | O     | O     |
| 20                           | 0h1514                | I1 Monitor(mA) | I1 input display                  | 0-20 (mA)                              | 0.00          | O                  | 146  | O            | O   | O   | O     | O     |
| 22                           | 0h1516                | I1 Filter      | I1 input filter time constant     | 0-10000 (ms)                           | 10            | O                  | 146  | O            | O   | O   | O     | O     |
| 23                           | 0h1517                | I1 Curr x1     | I1 minimum input current          | 0-20 (mA)                              | 4.00          | O                  | 146  | O            | O   | O   | O     | O     |
| 24                           | 0h1518                | I1 Perc y1     | Output at I1 minimum current (%)  | 0-100 (%)                              | 0.00          | O                  | 146  | O            | O   | O   | O     | O     |
| 25                           | 0h1519                | I1 Curr x2     | I1 maximum input current          | 4-20 (mA)                              | 20.00         | O                  | 146  | O            | O   | O   | O     | O     |
| 26                           | 0h151A                | I1 Perc y2     | Output at I1 maximum current      | 0-100 (%)                              | 100.00        | O                  | 146  | O            | O   | O   | O     | O     |
| 31                           | 0h151F                | I1 Inverting   | Rotation direction change         | 0 No<br>1 Yes                          | 0: No         | O                  | 146  | O            | O   | O   | O     | O     |
| 32                           | 0h1520                | I1 Quantizing  | I1 quantization level             | 0.04-10 (%)                            | 0.04          | O                  | 146  | O            | O   | O   | O     | O     |

Note 24) IN-12-15 codes are displayed only when IN-06 (V1 Polarity) is set as "Bipolar".



Input Terminal Block Function Group (PAR → IN)

| No.                           | Communication Address | LCD Display    | Name                              | Setting Range | Initial Value | Shift in Operation | Page | Control Mode |     |     |       |       |
|-------------------------------|-----------------------|----------------|-----------------------------------|---------------|---------------|--------------------|------|--------------|-----|-----|-------|-------|
|                               |                       |                |                                   |               |               |                    |      | V / F        | S L | V C | S L T | V C T |
| 35<br><small>Note 25)</small> | 0h1523                | V2 Monitor(V)  | V2 input display                  | 0-10 (V)      | 0.00          | O                  | 148  | O            | O   | O   | O     | O     |
| 36                            | 0h1524                | V2 Polarity    | V1 input polarity selection       | 0 Unipolar    | 1: Bipolar    | O                  | 148  | O            | O   | O   | O     | O     |
|                               |                       |                |                                   | 1 Bipolar     |               |                    |      |              |     |     |       |       |
| 37                            | 0h1525                | V2 Filter      | V2 input filter time constant     | 0-10000 (ms)  | 10            | O                  | 148  | O            | O   | O   | O     | O     |
| 38                            | 0h1526                | V2 Volt x1     | V2 minimum input voltage          | 0-10 (V)      | 0.00          | O                  | 148  | O            | O   | O   | O     | O     |
| 39                            | 0h1527                | V2 Perc y1     | Output at V2 minimum voltage (%)  | 0-100 (%)     | 0.00          | O                  | 148  | O            | O   | O   | O     | O     |
| 40                            | 0h1528                | V2 Volt x2     | V2 maximum input voltage          | 0-10 (V)      | 10.00         | O                  | 148  | O            | O   | O   | O     | O     |
| 41                            | 0h1529                | V2 Perc y2     | Output at V2 maximum voltage (%)  | 0-100 (%)     | 100.00        | O                  | 148  | O            | O   | O   | O     | O     |
| 42                            | 0h152A                | V2 -Volt x1'   | V2 -minimum input voltage         | -10-0 (V)     | 0.00          | O                  | 148  | O            | O   | O   | O     | O     |
| 43                            | 0h152B                | V2 -Perc y1'   | Output at V2 -minimum voltage (%) | -100-0 (%)    | 0.00          | O                  | 148  | O            | O   | O   | O     | O     |
| 44                            | 0h152C                | V2 -Volt x2'   | V2 -maximum input voltage         | -10-0 (V)     | -10.00        | O                  | 148  | O            | O   | O   | O     | O     |
| 45                            | 0h152D                | V2 -Perc y2'   | Output at V2 -maximum voltage (%) | -100-0 (%)    | -100.00       | O                  | 148  | O            | O   | O   | O     | O     |
| 46                            | 0h152E                | V2 Inverting   | Rotation direction change         | 0 No          | 0:No          | O                  | 148  | O            | O   | O   | O     | O     |
|                               |                       |                |                                   | 1 Yes         |               |                    |      |              |     |     |       |       |
| 47                            | 0h152F                | V2 Quantizing  | V2 quantization level             | 0.04-10 (%)   | 0.04          | O                  | 148  | O            | O   | O   | O     | O     |
| 50                            | 0h1532                | I2 Monitor(mA) | I2 input display                  | 0-20 (mA)     | 0.00          | O                  | 149  | O            | O   | O   | O     | O     |
| 52                            | 0h1534                | I2 Filter      | I2 input filter time constant     | 0-10000 (ms)  | 15            | O                  | 149  | O            | O   | O   | O     | O     |
| 53                            | 0h1535                | I2 Curr x1     | I2 minimum input current          | 0-20 (mA)     | 4.00          | O                  | 149  | O            | O   | O   | O     | O     |
| 54                            | 0h1536                | I2 Perc y1     | Output at I2 minimum current (%)  | 0-100 (%)     | 0.00          | O                  | 149  | O            | O   | O   | O     | O     |
| 55                            | 0h1537                | I2 Curr x2     | I2 maximum input current          | 0-20 (mA)     | 20.00         | O                  | 149  | O            | O   | O   | O     | O     |
| 56                            | 0h1538                | I2 Perc y2     | Output at I2 maximum current (%)  | 0-100 (%)     | 100.00        | O                  | 149  | O            | O   | O   | O     | O     |
| 61                            | 0h153D                | I2 Inverting   | Rotation direction change         | 0 No          | 0:No          | O                  | 149  | O            | O   | O   | O     | O     |
|                               |                       |                |                                   | 1 Yes         |               |                    |      |              |     |     |       |       |
| 62                            | 0h153F                | I2 Quantizing  | I2 quantization level             | 0.04-10 (%)   | 0.04          | O                  | 149  | O            | O   | O   | O     | O     |

\*  The grey cells indicate a hidden code which is only visible when setting a code.

Note 25) IN-35-62 codes are displayed only when the expansion IO module is installed.

**Input Terminal Block Function Group (PAR → IN)**

| No.                          | Communication Address | LCD Display | Name                          | Setting Range | Initial Value | Shift in Operation | Page | Control Mode |     |     |       |       |   |
|------------------------------|-----------------------|-------------|-------------------------------|---------------|---------------|--------------------|------|--------------|-----|-----|-------|-------|---|
|                              |                       |             |                               |               |               |                    |      | V / F        | S L | V C | S L T | V C T |   |
| 65                           | 0h1541                | P1 Define   | P1 terminal function setting  | 0             | NONE          | 1:FX               | X    | 158          | O   | O   | O     | O     | O |
|                              |                       |             |                               | 1             | FX            |                    |      |              |     |     |       |       |   |
| 66                           | 0h1542                | P2 Define   | P2 terminal function setting  | 2             | RX            | 2:RX               | X    | 158          | X   | X   | O     | O     | O |
| 67                           | 0h1543                | P3 Define   | P3 terminal function setting  | 3             | RST           | 5:BX               | X    | 329          | O   | O   | O     | O     | O |
| 68                           | 0h1544                | P4 Define   | P4 terminal function setting  | 4             | External Trip | 3:RST              | X    | 318          | O   | O   | O     | O     | O |
| 69                           | 0h1545                | P5 Define   | P5 terminal function setting  | 5             | BX            | 7:Sp-L             | X    | 328          | O   | O   | O     | O     | O |
| 70                           | 0h1546                | P6 Define   | P6 terminal function setting  | 6             | JOG           | 8:Sp-M             | X    | 199          | O   | O   | O     | O     | O |
| 71                           | 0h1547                | P7 Define   | P7 terminal function setting  | 7             | Speed-L       | 9:Sp-H             | X    | 154          | O   | O   | O     | O     | O |
| 72                           | 0h1548                | P8 Define   | P8 terminal function setting  | 8             | Speed-M       | 6:JOG              | X    | 154          | O   | O   | O     | O     | O |
| 73<br><small>Note26)</small> | 0h1549                | P9 Define   | P9 terminal function setting  | 9             | Speed-H       | 0:NONE             | X    | 154          | O   | O   | O     | O     | O |
| 74                           | 0h154A                | P10 Define  | P10 terminal function setting | 10            | Speed-X       | 0:NONE             | X    | 154          | O   | O   | O     | O     | O |
| 75                           | 0h154B                | P11 Define  | P11 terminal function setting | 11            | XCEL-L        | 0:NONE             | X    | 168          |     |     |       |       |   |
|                              |                       |             |                               | 12            | XCEL-M        |                    |      | 168          |     |     |       |       |   |
|                              |                       |             |                               | 13            | RUN Enable    |                    |      | 207          |     |     |       |       |   |
|                              |                       |             |                               | 14            | 3-Wire        |                    |      | 206          |     |     |       |       |   |
|                              |                       |             |                               | 15            | 2nd Source    |                    |      | 190          |     |     |       |       |   |
|                              |                       |             |                               | 16            | Exchange      |                    |      | 253          |     |     |       |       |   |
|                              |                       |             |                               | 17            | Up            |                    |      | 202          |     |     |       |       |   |
|                              |                       |             |                               | 18            | Down          |                    |      | 202          |     |     |       |       |   |
|                              |                       |             |                               | 19            | U/D Save      |                    |      | 202          |     |     |       |       |   |
|                              |                       |             |                               | 20            | U/D Clear     |                    |      | 202          |     |     |       |       |   |
|                              |                       |             |                               | 21            | Analog Hold   |                    |      | 153          |     |     |       |       |   |
|                              |                       |             |                               | 22            | I-Term Clear  |                    |      | 210          |     |     |       |       |   |
|                              |                       |             |                               | 23            | PID Openloop  |                    |      | 210          |     |     |       |       |   |
|                              |                       |             |                               | 24            | P Gain2       |                    |      | 210          |     |     |       |       |   |
|                              |                       |             |                               | 25            | XCEL Stop     |                    |      | 173          |     |     |       |       |   |
|                              |                       |             |                               | 26            | 2nd Motor     |                    |      | 251          |     |     |       |       |   |
|                              |                       |             |                               | 27            | Trv Offset Lo |                    |      | 266          |     |     |       |       |   |
|                              |                       |             |                               | 28            | Trv Offset Hi |                    |      | 266          |     |     |       |       |   |
|                              |                       |             |                               | 29            | Interlock 1   |                    |      | 275          |     |     |       |       |   |
|                              |                       |             |                               | 30            | Interlock 2   |                    |      | 275          |     |     |       |       |   |
|                              |                       |             |                               | 31            | Interlock 3   |                    |      | 275          |     |     |       |       |   |
|                              |                       |             |                               | 32            | Interlock 4   |                    |      | 275          |     |     |       |       |   |

Function Table

\*  The grey cells indicate a hidden code which is only visible when setting a code.  
Note 26) IN73-75 codes are displayed only when the expansion IO module is installed.

## Table of Functions

### Input Terminal Block Function Group (PAR → IN)

| No. | Communication Address | LCD Display  | Name   | Setting Range          | Initial Value | Shift in Operation | Page | Control Mode |     |     |     |     |   |   |
|-----|-----------------------|--------------|--|------------------------|---------------|--------------------|------|--------------|-----|-----|-----|-----|---|---|
|     |                       |              |  |                        |               |                    |      | V / F        | S L | V C | S L | V C |   |   |
|     |                       |              |  | 33                     | -Reserved-    |                    | -    |              |     |     |     |     |   |   |
|     |                       |              |  | 34                     | Pre Excite    |                    | -    |              |     |     |     |     |   |   |
|     |                       |              |  | 35                     | Speed/Torque  |                    | 236  |              |     |     |     |     |   |   |
|     |                       |              |  | 36                     | ASR Gain 2    |                    | 233  |              |     |     |     |     |   |   |
|     |                       |              |  | 37                     | ASR P/PI      |                    | 233  |              |     |     |     |     |   |   |
|     |                       |              |  | 38                     | Timer In      |                    | 265  |              |     |     |     |     |   |   |
|     |                       |              |  | 39                     | Thermal In    |                    | 315  |              |     |     |     |     |   |   |
|     |                       |              |  | 40                     | Dis Aux Ref   |                    | 194  |              |     |     |     |     |   |   |
|     |                       |              |  | 41                     | -Reserved-    |                    | -    |              |     |     |     |     |   |   |
|     |                       |              |  | 42                     | -Reserved-    |                    | -    |              |     |     |     |     |   |   |
|     |                       |              |  | 43                     | -Reserved-    |                    | -    |              |     |     |     |     |   |   |
|     |                       |              |  | 44                     | -Reserved-    |                    | -    |              |     |     |     |     |   |   |
|     |                       |              |  | 45                     | -Reserved-    |                    | -    |              |     |     |     |     |   |   |
|     |                       |              |  | 46                     | FWD JOG       |                    | 200  |              |     |     |     |     |   |   |
|     |                       |              |  | 47                     | REV JOG       |                    | 200  |              |     |     |     |     |   |   |
|     |                       |              |  | 48                     | Trq Bias      |                    | 235  |              |     |     |     |     |   |   |
|     |                       |              |  | 49                     | XCEL-H        |                    | 168  |              |     |     |     |     |   |   |
|     |                       |              |  | 50                     | KEB Select    |                    | 239  |              |     |     |     |     |   |   |
|     |                       |              |  | 51                     | Fire Mode     |                    | 280  |              |     |     |     |     |   |   |
| 85  | 0h1555                | DI On Delay  | Multi-function input terminal On filter      | 0-10000 (ms)           | 10            | O                  | 192  | O            | O   | O   | O   | O   | O | O |
| 86  | 0h1556                | DI Off Delay | Multi-function input terminal Off filter     | 0-10000 (ms)           | 3             | O                  | 192  | O            | O   | O   | O   | O   | O | O |
| 87  | 0h1557                | DINC/NO Sel  | Multi-function input contact point selection | P8 - P1                | 0000 0000     | X                  | 192  | O            | O   | O   | O   | O   | O | O |
|     |                       |              |  | 0 A contact point (NO) |               |                    |      |              |     |     |     |     |   |   |
|     |                       |              |  | 1 B contact point (NC) |               |                    |      |              |     |     |     |     |   |   |
| 88  | 0h1558                | RunOn Delay  | Operating command delay time                 | 0-100 (sec)            | 0.00          | X                  | 192  | O            | O   | O   | O   | O   | O | O |
| 89  | 0h1559                | InCheck Time | Sequential command delay time                | 1-5000 (ms)            | 1             | X                  | 192  | O            | O   | O   | O   | O   | O | O |
| 90  | 0h155A                | DI Status    | Multi-function input terminal status         | P8 - P1                | 0000 0000     | O                  | 192  | O            | O   | O   | O   | O   | O | O |
|     |                       |              |  | 0 Open (Off)           |               |                    |      |              |     |     |     |     |   |   |
|     |                       |              |  | 1 Connection (On)      |               |                    |      |              |     |     |     |     |   |   |

## 13.6 Parameter Mode – Output Terminal Block Function Group (→OUT)

### Output Terminal Block Function Group (PAR → OUT)

| No. | Communication Address | LCD Display | Name                     | Setting Range | Initial Value | Shift in Operation | Page | Control Mode |     |     |       |       |   |
|-----|-----------------------|-------------|--------------------------|---------------|---------------|--------------------|------|--------------|-----|-----|-------|-------|---|
|     |                       |             |                          |               |               |                    |      | V / F        | S L | V C | S L T | V C T |   |
| 00  | -                     | JumpCode    | Jump code                | 0-99          | 30            | 0                  | -    | 0            | 0   | 0   | 0     | 0     | 0 |
| 01  | 0h1601                | AO1 Mode    | Analog output 1          | 0             | Frequency     | 0: Frequency       | 0    | 291          | 0   | 0   | 0     | 0     | 0 |
|     |                       |             |                          | 1             | Current       |                    |      |              |     |     |       |       |   |
|     |                       |             |                          | 2             | Voltage       |                    |      |              |     |     |       |       |   |
|     |                       |             |                          | 3             | DC Link Volt  |                    |      |              |     |     |       |       |   |
|     |                       |             |                          | 4             | Torque        |                    |      |              |     |     |       |       |   |
|     |                       |             |                          | 5             | Watt          |                    |      |              |     |     |       |       |   |
|     |                       |             |                          | 6             | Idss          |                    |      |              |     |     |       |       |   |
|     |                       |             |                          | 7             | Iqss          |                    |      |              |     |     |       |       |   |
|     |                       |             |                          | 8             | Target Freq   |                    |      |              |     |     |       |       |   |
|     |                       |             |                          | 9             | Ramp Freq     |                    |      |              |     |     |       |       |   |
|     |                       |             |                          | 10            | Speed Fdb     |                    |      |              |     |     |       |       |   |
|     |                       |             |                          | 11            | Speed Dev     |                    |      |              |     |     |       |       |   |
|     |                       |             |                          | 12            | PIDRef Value  |                    |      |              |     |     |       |       |   |
|     |                       |             |                          | 13            | PIDFdb Value  |                    |      |              |     |     |       |       |   |
|     |                       |             |                          | 14            | PID Output    |                    |      |              |     |     |       |       |   |
| 15  | Constant              |             |                          |               |               |                    |      |              |     |     |       |       |   |
| 02  | 0h1602                | AO1 Gain    | Analog output1 gain      | -1000-1000(%) | 100.0         | 0                  | 291  | 0            | 0   | 0   | 0     | 0     |   |
| 03  | 0h1603                | AO1 Bias    | Analog output 1 bias     | -100-100(%)   | 0.0           | 0                  | 291  | 0            | 0   | 0   | 0     | 0     |   |
| 04  | 0h1604                | AO1 Filter  | Analog output1 filter    | 0-10000 (ms)  | 5             | 0                  | 291  | 0            | 0   | 0   | 0     | 0     |   |
| 05  | 0h1605                | AO1 Const % | Analog constant output 1 | 0-1000(%)     | 0.0           | 0                  | 291  | 0            | 0   | 0   | 0     | 0     |   |
| 06  | 0h1606                | AO1 Monitor | Analog output 1 monitor  | 0-1000(%)     | 0.0           | -                  | 291  | 0            | 0   | 0   | 0     | 0     |   |
| 07  | 0h1607                | AO2 Mode    | Analog output 2 item     | 0             | Frequency     | 0: Frequency       | 0    | 293          | 0   | 0   | 0     | 0     | 0 |
|     |                       |             |                          | 1             | Current       |                    |      |              |     |     |       |       |   |
|     |                       |             |                          | 2             | Voltage       |                    |      |              |     |     |       |       |   |
|     |                       |             |                          | 3             | DC Link Volt  |                    |      |              |     |     |       |       |   |
|     |                       |             |                          | 4             | Torque        |                    |      |              |     |     |       |       |   |
|     |                       |             |                          | 5             | Watt          |                    |      |              |     |     |       |       |   |
|     |                       |             |                          | 6             | Idss          |                    |      |              |     |     |       |       |   |
|     |                       |             |                          | 7             | Iqss          |                    |      |              |     |     |       |       |   |
|     |                       |             |                          | 8             | Target Freq   |                    |      |              |     |     |       |       |   |
|     |                       |             |                          | 9             | Ramp Freq     |                    |      |              |     |     |       |       |   |
|     |                       |             |                          | 10            | Speed Fdb     |                    |      |              |     |     |       |       |   |
|     |                       |             |                          | 11            | Speed Dev     |                    |      |              |     |     |       |       |   |
|     |                       |             |                          | 12            | PIDRef Value  |                    |      |              |     |     |       |       |   |
|     |                       |             |                          | 13            | PIDFbk Value  |                    |      |              |     |     |       |       |   |
|     |                       |             |                          | 14            | PID Output    |                    |      |              |     |     |       |       |   |
| 15  | Constant              |             |                          |               |               |                    |      |              |     |     |       |       |   |

Function Table

Output Terminal Block Function Group (PAR → OUT)

| No.                          | Communication Address | LCD Display | Name                     | Setting Range  | Initial Value | Shift in Operation | Page | Control Mode |     |     |       |       |   |
|------------------------------|-----------------------|-------------|--------------------------|----------------|---------------|--------------------|------|--------------|-----|-----|-------|-------|---|
|                              |                       |             |                          |                |               |                    |      | V / F        | S L | V C | S L T | V C T |   |
| 08                           | 0h1608                | AO2 Gain    | Analog output 2 gain     | -1000~1000 (%) | 80.0          | O                  | 293  | O            | O   | O   | O     | O     |   |
| 09                           | 0h1609                | AO2 Bias    | Analog output 2 bias     | -100~100 (%)   | 20.0          | O                  | 293  | O            | O   | O   | O     | O     |   |
| 10                           | 0h160A                | AO2 Filter  | Analog output 2 filter   | 0~10000 (ms)   | 5             | O                  | 293  | O            | O   | O   | O     | O     |   |
| 11                           | 0h160B                | AO2 Const % | Analog constant output 2 | 0~100 (%)      | 0.0           | O                  | 293  | O            | O   | O   | O     | O     |   |
| 12                           | 0h160C                | AO2 Monitor | Analog output 2 monitor  | 0~1000 (%)     | 0.0           | O                  | 293  | O            | O   | O   | O     | O     |   |
| 14<br><small>Note27)</small> | 0h160E                | AO3 Mode    | Analog output 3 item     | 0              | Frequency     | 0: Frequency       | O    | 296          | O   | O   | O     | O     | O |
|                              |                       |             |                          | 1              | Current       |                    |      |              |     |     |       |       |   |
|                              |                       |             |                          | 2              | Voltage       |                    |      |              |     |     |       |       |   |
|                              |                       |             |                          | 3              | DC Link Volt  |                    |      |              |     |     |       |       |   |
|                              |                       |             |                          | 4              | Torque        |                    |      |              |     |     |       |       |   |
|                              |                       |             |                          | 5              | Watt          |                    |      |              |     |     |       |       |   |
|                              |                       |             |                          | 6              | Idss          |                    |      |              |     |     |       |       |   |
|                              |                       |             |                          | 7              | Iqss          |                    |      |              |     |     |       |       |   |
|                              |                       |             |                          | 8              | Target Freq   |                    |      |              |     |     |       |       |   |
|                              |                       |             |                          | 9              | Ramp Freq     |                    |      |              |     |     |       |       |   |
|                              |                       |             |                          | 10             | Speed Fdb     |                    |      |              |     |     |       |       |   |
|                              |                       |             |                          | 11             | Speed Dev     |                    |      |              |     |     |       |       |   |
|                              |                       |             |                          | 12             | PID Ref Value |                    |      |              |     |     |       |       |   |
|                              |                       |             |                          | 13             | PID Fbk Value |                    |      |              |     |     |       |       |   |
|                              |                       |             |                          | 14             | PID Output    |                    |      |              |     |     |       |       |   |
| 15                           | Constant              |             |                          |                |               |                    |      |              |     |     |       |       |   |
| 15                           | 0h160F                | AO3 Gain    | Analog output 3 gain     | -1000~1000 (%) | 100.0         | O                  | 296  | O            | O   | O   | O     | O     |   |
| 16                           | 0h1610                | AO3 Bias    | Analog output 3 bias     | -100~100 (%)   | 0.0           | O                  | 296  | O            | O   | O   | O     | O     |   |
| 17                           | 0h1611                | AO3 Filter  | Analog output 3 filter   | 0~10000 (ms)   | 5             | O                  | 296  | O            | O   | O   | O     | O     |   |
| 18                           | -                     | AO3 Const % | Analog constant output 3 | 0~100 (%)      | 0.0           | O                  | 296  | O            | O   | O   | O     | O     |   |
| 19                           | 0h1613                | AO3 Monitor | Analog output 3 monitor  | -1000~1000 (%) | 0.0           | O                  | 296  | O            | O   | O   | O     | O     |   |
| 20                           | 0h1614                | AO4 Mode    | Analog output 4 item     | 0              | Frequency     | 0: Frequency       | O    | 297          | O   | O   | O     | O     | O |
|                              |                       |             |                          | 1              | Current       |                    |      |              |     |     |       |       |   |
|                              |                       |             |                          | 2              | Voltage       |                    |      |              |     |     |       |       |   |
|                              |                       |             |                          | 3              | DC Link Volt  |                    |      |              |     |     |       |       |   |
|                              |                       |             |                          | 4              | Torque        |                    |      |              |     |     |       |       |   |
|                              |                       |             |                          | 5              | Watt          |                    |      |              |     |     |       |       |   |
|                              |                       |             |                          | 6              | Idss          |                    |      |              |     |     |       |       |   |
|                              |                       |             |                          | 7              | Iqss          |                    |      |              |     |     |       |       |   |
|                              |                       |             |                          | 8              | Target Freq   |                    |      |              |     |     |       |       |   |
|                              |                       |             |                          | 9              | Ramp Freq     |                    |      |              |     |     |       |       |   |
|                              |                       |             |                          | 10             | Speed Fdb     |                    |      |              |     |     |       |       |   |
|                              |                       |             |                          | 11             | Speed Dev     |                    |      |              |     |     |       |       |   |
|                              |                       |             |                          | 12             | PID Ref Value |                    |      |              |     |     |       |       |   |
|                              |                       |             |                          | 13             | PID Fbk Value |                    |      |              |     |     |       |       |   |
|                              |                       |             |                          | 14             | PID Output    |                    |      |              |     |     |       |       |   |
| 15                           | Constant              |             |                          |                |               |                    |      |              |     |     |       |       |   |

Output Terminal Block Function Group (PAR → OUT)

| No.                          | Communication Address | LCD Display   | Name                     | Setting Range                        | Initial Value | Shift in Operation | Page | Control Mode |     |     |       |       |   |
|------------------------------|-----------------------|---------------|--------------------------|--------------------------------------|---------------|--------------------|------|--------------|-----|-----|-------|-------|---|
|                              |                       |               |                          |                                      |               |                    |      | V / F        | S L | V C | S L T | V C T |   |
| 21                           | 0h1615                | AO4 Gain      | Analog output 4 gain     | -1000-1000 (%)                       | 80.0          | -                  | 297  | O            | O   | O   | O     | O     | O |
| 22                           | 0h1616                | AO4 Bias      | Analog output 4 bias     | -100-100 (%)                         | 20.0          | O                  | 297  | O            | O   | O   | O     | O     | O |
| 23                           | 0h1617                | AO4 Filter    | Analog output 4 filter   | 0-10000 (ms)                         | 5             | O                  | 297  | O            | O   | O   | O     | O     | O |
| 24                           | -                     | AO4 Const %   | Analog constant output 4 | 0-100 (%)                            | 0.0           | O                  | 297  | O            | O   | O   | O     | O     | O |
| 25                           | 0h1619                | AO4 Monitor   | Analog output 4 monitor  | 0-1000 (%)                           | 0.0           | O                  | 297  | O            | O   | O   | O     | O     | O |
| 30                           | 0h161E                | Trip Out Mode | Failure output item      | Bit 000 - 111                        | 010           | O                  | 298  | O            | O   | O   | O     | O     | O |
|                              |                       |               |                          | 1 Low voltage                        |               |                    |      |              |     |     |       |       |   |
|                              |                       |               |                          | 2 Failure other than low voltage     |               |                    |      |              |     |     |       |       |   |
|                              |                       |               |                          | 3 Final failure of automatic restart |               |                    |      |              |     |     |       |       |   |
| 31                           | 0h161F                | Relay 1       | Multi-function relay 1   | 0 NONE                               | 29:Trip       | O                  | 298  | O            | O   | O   | O     | O     | O |
| 32                           | 0h1620                | Relay 2       | Multi-function relay 2   | 1 FDT-1                              | 14:Run        | O                  | 298  | O            | O   | O   | O     | O     | O |
| 33                           | 0h1621                | Q1 Define     | Multi-function output 1  | 2 FDT-2                              | 1:FDT-1       | O                  | 298  | O            | O   | O   | O     | O     | O |
| 34<br><small>Note28)</small> | 0h1622                | Relay 3       | Multi-function relay 3   | 3 FDT-3                              | 2:FDT-2       | O                  | 298  | O            | O   | O   | O     | O     | O |
| 35                           | 0h1623                | Relay 4       | Multi-function relay 4   | 4 FDT-4                              | 3:FDT-3       | O                  | 298  | O            | O   | O   | O     | O     | O |
| 36                           | 0h1624                | Relay 5       | Multi-function relay 5   | 5 Over Load                          | 4:FDT-4       | O                  | 298  | O            | O   | O   | O     | O     | O |
|                              |                       |               |                          | 6 IOL                                |               |                    |      |              |     |     |       |       |   |
|                              |                       |               |                          | 7 Under Load                         |               |                    |      |              |     |     |       |       |   |
|                              |                       |               |                          | 8 Fan Warning                        |               |                    |      |              |     |     |       |       |   |
|                              |                       |               |                          | 9 Stall                              |               |                    |      |              |     |     |       |       |   |
|                              |                       |               |                          | 10 Over Voltage                      |               |                    |      |              |     |     |       |       |   |
|                              |                       |               |                          | 11 Low Voltage                       |               |                    |      |              |     |     |       |       |   |
|                              |                       |               |                          | 12 Over Heat                         |               |                    |      |              |     |     |       |       |   |
|                              |                       |               |                          | 13 Lost Command                      |               |                    |      |              |     |     |       |       |   |
|                              |                       |               |                          | 14 Run                               |               |                    |      |              |     |     |       |       |   |
|                              |                       |               |                          | 15 Stop                              |               |                    |      |              |     |     |       |       |   |
|                              |                       |               |                          | 16 Steady                            |               |                    |      |              |     |     |       |       |   |
|                              |                       |               |                          | 17 Inverter Line                     |               |                    |      |              |     |     |       |       |   |
|                              |                       |               |                          | 18 Comm Line                         |               |                    |      |              |     |     |       |       |   |
|                              |                       |               |                          | 19 Speed Search                      |               |                    |      |              |     |     |       |       |   |
|                              |                       |               |                          | 20 -Reserved-                        |               |                    |      |              |     |     |       |       |   |
|                              |                       |               |                          | 21 -Reserved-                        |               |                    |      |              |     |     |       |       |   |
|                              |                       |               |                          | 22 Ready                             |               |                    |      |              |     |     |       |       |   |
|                              |                       |               |                          | 23 Trv Acc                           |               |                    |      |              |     |     |       |       |   |
|                              |                       |               |                          | 24 Trv Dec                           |               |                    |      |              |     |     |       |       |   |
|                              |                       |               |                          | 25 MMC                               |               |                    |      |              |     |     |       |       |   |
|                              |                       |               |                          | 26 Zspd Dect                         |               |                    |      |              |     |     |       |       |   |
|                              |                       |               |                          | 27 Torque Dect                       |               |                    |      |              |     |     |       |       |   |
|                              |                       |               |                          | 28 Timer Out                         |               |                    |      |              |     |     |       |       |   |

Note 27) OUT 14-25 codes are displayed only when the expansion IO module is installed.

Note 28) OUT 34-36 codes are displayed only when the expansion IO module is installed.

Output Terminal Block Function Group (PAR → OUT)

| No. | Communi-<br>cation<br>Address | LCD Display     | Name  | Setting Range            | Initial Value | Shift in<br>Opera-<br>tion | Page | Control Mode |        |        |             |             |   |   |   |   |   |   |   |
|-----|-------------------------------|-----------------|---|--------------------------|---------------|----------------------------|------|--------------|--------|--------|-------------|-------------|---|---|---|---|---|---|---|
|     |                               |                 |   |                          |               |                            |      | V<br>/<br>F  | S<br>L | V<br>C | S<br>L<br>T | V<br>C<br>T |   |   |   |   |   |   |   |
|     |                               |                 |   | 29 Trip                  |               |                            |      |              |        |        |             |             |   |   |   |   |   |   |   |
|     |                               |                 |   | 30 Lost Keypad           |               |                            |      |              |        |        |             |             |   |   |   |   |   |   |   |
|     |                               |                 |   | 31 DB Warn %ED           |               |                            |      |              |        |        |             |             |   |   |   |   |   |   |   |
|     |                               |                 |   | 32 ENC Tune              |               |                            |      |              |        |        |             |             |   |   |   |   |   |   |   |
|     |                               |                 |   | 33 ENC Dir               |               |                            |      |              |        |        |             |             |   |   |   |   |   |   |   |
|     |                               |                 |   | 34 On/Off Control        |               |                            |      |              |        |        |             |             |   |   |   |   |   |   |   |
|     |                               |                 |   | 35 BR Control            |               |                            |      |              |        |        |             |             |   |   |   |   |   |   |   |
|     |                               |                 |   | 36 KEB Operating         |               |                            |      |              |        |        |             |             |   |   |   |   |   |   |   |
|     |                               |                 |   | 37 Fire Mode             |               |                            |      |              |        |        |             |             |   |   |   |   |   |   |   |
|     |                               |                 |   | 38 Run2                  |               |                            |      |              |        |        |             |             |   |   |   |   |   |   |   |
| 41  | 0h1629                        | DO Status       | Multi-function output monitoring              | -                        | 000           | X                          | 298  | -            | -      | -      | -           | -           | - | - | - | - | - | - | - |
| 50  | 0h1632                        | DO On Delay     | Multi-function output On delay                | 0-100 (sec)              | 0.00          | O                          | 305  | O            | O      | O      | O           | O           | O | O | O | O | O | O | O |
| 51  | 0h1633                        | DO Off Delay    | Multi-function output Off delay               | 0-100 (sec)              | 0.00          | O                          | 305  | O            | O      | O      | O           | O           | O | O | O | O | O | O | O |
| 52  | 0h1634                        | DO<br>NC/NO Sel | Multi-function output contact point selection | Q1,Relay2,Relay1         | 000           | X                          | 305  | O            | O      | O      | O           | O           | O | O | O | O | O | O | O |
|     |                               |                 |   | 0 A contact point (NO)   |               |                            |      |              |        |        |             |             |   |   |   |   |   |   |   |
|     |                               |                 |   | 1 B contact point (NC)   |               |                            |      |              |        |        |             |             |   |   |   |   |   |   |   |
| 53  | 0h1635                        | TripOut OnDly   | Failure output On delay                       | 0-100 (sec)              | 0.00          | O                          | 304  | O            | O      | O      | O           | O           | O | O | O | O | O | O | O |
| 54  | 0h1636                        | TripOut OffDly  | Failure output Off delay                      | 0-100.00 (sec)           | 0.00          | O                          | 304  | O            | O      | O      | O           | O           | O | O | O | O | O | O | O |
| 55  | 0h1637                        | TimerOn Delay   | Timer On delay                                | 0-100.00 (sec)           | 0.00          | O                          | 265  | O            | O      | O      | O           | O           | O | O | O | O | O | O | O |
| 56  | 0h1638                        | TimerOff Delay  | Timer Off delay                               | 0-100.00 (sec)           | 0.00          | O                          | 265  | O            | O      | O      | O           | O           | O | O | O | O | O | O | O |
| 57  | 0h1639                        | FDT Frequency   | Detected frequency                            | 0-maximum frequency (Hz) | 30.00         | O                          | 299  | O            | O      | O      | O           | O           | O | O | O | O | O | O | O |
| 58  | 0h163A                        | FDT Band        | Detected frequency width                      | 0-maximum frequency (Hz) | 10.00         | O                          | 299  | O            | O      | O      | O           | O           | O | O | O | O | O | O | O |
| 59  | 0h163B                        | TD Level        | Detected torque amount                        | 0-150 (%)                | 100           | O                          | 236  | X            | X      | O      | X           | O           | X | O | X | O | X | O | X |
| 60  | 0h163C                        | TD Band         | Detected torque width                         | 0-10 (%)                 | 5.0           | O                          | 236  | X            | X      | O      | X           | O           | X | O | X | O | X | O | X |

\*  The grey cells indicate a hidden code which is only visible when setting a code.

# 13.7 Parameter Mode – Communication Function Group (→COM)

## Communication Function Group (PAR → COM)

| No.                            | Communi-cation Address | LCD Display    | Name                                 | Setting Range   | Initial Value | Shift in Opera-tion | Page   | Control Mode |       |       |       |       |   |
|--------------------------------|------------------------|----------------|--------------------------------------|-----------------|---------------|---------------------|--------|--------------|-------|-------|-------|-------|---|
|                                |                        |                |                                      |                 |               |                     |        | V / F        | S / L | V / C | S / L | V / C |   |
| 00                             | -                      | Jump Code      | Jump code                            | 0-99            | 20            | 0                   | -      | 0            | 0     | 0     | 0     | 0     | 0 |
| 01                             | 0h1701                 | Int485 St ID   | Built-in communication inverter ID   | 1-250           | 1             | 0                   | 337    | 0            | 0     | 0     | 0     | 0     | 0 |
| 02                             | 0h1702                 | Int485 Proto   | Built-in communication protocol      | 0 ModBus RTU    | 0: ModBus RTU | 0                   | 337    | 0            | 0     | 0     | 0     | 0     | 0 |
|                                |                        |                |                                      | 1 --Reserved -- |               |                     |        |              |       |       |       |       |   |
|                                |                        |                |                                      | 2 Serial Debug  |               |                     |        |              |       |       |       |       |   |
| 03                             | 0h1703                 | Int485 BaudR   | Built-in communication speed         | 0 1200 bps      | 3: 9600 bps   | 0                   | 337    | 0            | 0     | 0     | 0     | 0     | 0 |
|                                |                        |                |                                      | 1 2400 bps      |               |                     |        |              |       |       |       |       |   |
|                                |                        |                |                                      | 2 4800 bps      |               |                     |        |              |       |       |       |       |   |
|                                |                        |                |                                      | 3 9600 bps      |               |                     |        |              |       |       |       |       |   |
|                                |                        |                |                                      | 4 19200 bps     |               |                     |        |              |       |       |       |       |   |
|                                |                        |                |                                      | 5 38400 bps     |               |                     |        |              |       |       |       |       |   |
| 04                             | 0h1704                 | Int485 Mode    | Built-in communication frame setting | 0 D8/PN/S1      | 0: D8/PN/S1   | -                   | 337    | 0            | 0     | 0     | 0     | 0     | 0 |
|                                |                        |                |                                      | 1 D8/PN/S2      |               |                     |        |              |       |       |       |       |   |
|                                |                        |                |                                      | 2 D8/PE/S1      |               |                     |        |              |       |       |       |       |   |
|                                |                        |                |                                      | 3 D8/PO/S1      |               |                     |        |              |       |       |       |       |   |
| 05                             | 0h1705                 | Resp Delay     | Transmission delay after reception   | 0-1000 (ms)     | 5 ms          | 0                   | 337    | 0            | 0     | 0     | 0     | 0     | 0 |
| 06<br><small>Note29-1)</small> | 0h1706                 | FBus S/W Ver   | Communication option SW version      | -               | 1.00          | 0                   | Option | 0            | 0     | 0     | 0     | 0     | 0 |
| 07                             | 0h1707                 | FBus ID        | Communication option inverter ID     | 0-255           | 1             | 0                   | Option | 0            | 0     | 0     | 0     | 0     | 0 |
| 08                             | 0h1708                 | FBUS BaudRate  | FBus communication speed             | -               | 12 Mbps       |                     | Option | 0            | 0     | 0     | 0     | 0     | 0 |
| 09                             | 0h1709                 | FieldBus LED   | Communication option LED status      | -               | -             | 0                   | Option | 0            | 0     | 0     | 0     | 0     | 0 |
| 30                             | 0h171E                 | ParaStatus Num | Number of output parameters          | 0-8             | 3             | 0                   | 342    | 0            | 0     | 0     | 0     | 0     | 0 |
| 31                             | 0h171F                 | Para Stauts-1  | Output address 1                     | 0000-FFFF Hex   | 000A          | 0                   | 342    | 0            | 0     | 0     | 0     | 0     | 0 |
| 32                             | 0h1720                 | Para Stauts-2  | Output address 2                     | 0000-FFFF Hex   | 000E          | 0                   | 342    | 0            | 0     | 0     | 0     | 0     | 0 |
| 33                             | 0h1721                 | Para Stauts-3  | Output address 3                     | 0000-FFFF Hex   | 000F          | 0                   | 342    | 0            | 0     | 0     | 0     | 0     | 0 |
| 34                             | 0h1722                 | Para Stauts-4  | Output address 4                     | 0000-FFFF Hex   | 0000          | 0                   | 342    | 0            | 0     | 0     | 0     | 0     | 0 |
| 35                             | 0h1723                 | Para Stauts-5  | Output address 5                     | 0000-FFFF Hex   | 0000          | 0                   | 342    | 0            | 0     | 0     | 0     | 0     | 0 |
| 36                             | 0h1724                 | Para Stauts-6  | Output address 6                     | 0000-FFFF Hex   | 0000          | 0                   | 342    | 0            | 0     | 0     | 0     | 0     | 0 |
| 37                             | 0h1725                 | Para Stauts-7  | Output address 7                     | 0000-FFFF Hex   | 0000          | 0                   | 342    | 0            | 0     | 0     | 0     | 0     | 0 |
| 38                             | 0h1726                 | Para Stauts-8  | Output address 8                     | 0000-FFFF Hex   | 0000          | 0                   | 342    | 0            | 0     | 0     | 0     | 0     | 0 |

\*  The grey cells indicate a hidden code which is only visible when setting a code.

Note 29-1) COM 06-17 codes are displayed only when the communication module is installed.

Refer to the Options manual for options.



## Table of Functions

### Communication Function Group (PAR → COM)

| No. | Communication Address | LCD Display    | Name                                  | Setting Range | Initial Value | Shift in Operation | Page | Control Mode |     |     |     |     |   |
|-----|-----------------------|----------------|---------------------------------------|---------------|---------------|--------------------|------|--------------|-----|-----|-----|-----|---|
|     |                       |                |                                       |               |               |                    |      | V / F        | S L | V C | S L | V C |   |
| 50  | 0h1732                | Para Ctrl Num  | Number of input parameters            | 0-8           | 2             | O                  | 342  | O            | O   | O   | O   | O   |   |
| 51  | 0h1733                | Para Control-1 | Input address 1                       | 0000-FFFF Hex | 0005          | X                  | 342  | O            | O   | O   | O   | O   |   |
| 52  | 0h1734                | Para Control-2 | Input address 2                       | 0000-FFFF Hex | 0006          | X                  | 342  | O            | O   | O   | O   | O   |   |
| 53  | 0h1735                | Para Control-3 | Input address 3                       | 0000-FFFF Hex | 0000          | X                  | 342  | O            | O   | O   | O   | O   |   |
| 54  | 0h1736                | Para Control-4 | Input address 4                       | 0000-FFFF Hex | 0000          | X                  | 342  | O            | O   | O   | O   | O   |   |
| 55  | 0h1737                | Para Control-5 | Input address 5                       | 0000-FFFF Hex | 0000          | X                  | 342  | O            | O   | O   | O   | O   |   |
| 56  | 0h1738                | Para Control-6 | Input address 6                       | 0000-FFFF Hex | 0000          | X                  | 342  | O            | O   | O   | O   | O   |   |
| 57  | 0h1739                | Para Control-7 | Input address 7                       | 0000-FFFF Hex | 0000          | X                  | 342  | O            | O   | O   | O   | O   |   |
| 58  | 0h173A                | Para Control-8 | Input address 8                       | 0000-FFFF Hex | 0000          | X                  | 342  | O            | O   | O   | O   | O   |   |
| 68  | 0h1744                | FBus Swap Sel  | Profibus swap                         | 0             | No            | 0:No               | X    | Option       | O   | O   | O   | O   | O |
|     |                       |                |                                       | 1             | Yes           |                    |      |              |     |     |     |     |   |
| 70  | 0h1746                | Virtual DI 1   | Communication multi-function input 1  | 0             | None          | 0:None             | O    | 339          | O   | O   | O   | O   | O |
| 71  | 0h1747                | Virtual DI 2   | Communication multi-function input 2  | 1             | FX            | 0:None             | O    | 339          | O   | O   | O   | O   | O |
| 72  | 0h1748                | Virtual DI 3   | Communication multi-function input 3  | 2             | RX            | 0:None             | O    | 339          | O   | O   | O   | O   | O |
| 73  | 0h1749                | Virtual DI 4   | Communication multi-function input 4  | 3             | RST           | 0:None             | O    | 339          | O   | O   | O   | O   | O |
| 74  | 0h174A                | Virtual DI 5   | Communication multi-function input 5  | 4             | External Trip | 0:None             | O    | 339          | O   | O   | O   | O   | O |
| 75  | 0h174B                | Virtual DI 6   | Communication multi-function input 6  | 5             | BX            | 0:None             | O    | 339          | O   | O   | O   | O   | O |
| 76  | 0h174C                | Virtual DI 7   | Communication multi-function input 7  | 6             | JOG           | 0:None             | O    | 339          | O   | O   | O   | O   | O |
| 77  | 0h174D                | Virtual DI 8   | Communication multi-function input 8  | 7             | Speed-L       | 0:None             | O    | 339          | O   | O   | O   | O   | O |
| 78  | 0h174E                | Virtual DI 9   | Communication multi-function input 9  | 8             | Speed-M       | 0:None             | O    | 339          | O   | O   | O   | O   | O |
| 79  | 0h174F                | Virtual DI 10  | Communication multi-function input 10 | 9             | Speed-H       | 0:None             | O    | 339          | O   | O   | O   | O   | O |
| 80  | 0h1750                | Virtual DI 11  | Communication multi-function input 11 | 10            | Speed-X       | 0:None             | O    | 339          | O   | O   | O   | O   | O |
| 81  | 0h1751                | Virtual DI 12  | Communication multi-function input 12 | 11            | XCEL-L        | 0:None             | O    | 339          | O   | O   | O   | O   | O |
| 82  | 0h1752                | Virtual DI 13  | Communication multi-function input 13 | 12            | XCEL-M        | 0:None             | O    | 339          | O   | O   | O   | O   | O |
| 83  | 0h1753                | Virtual DI 14  | Communication multi-function input 14 | 13            | RUN Enable    | 0:None             | O    | 339          | O   | O   | O   | O   | O |
| 84  | 0h1754                | Virtual DI 15  | Communication multi-function input 15 | 14            | 3-Wire        | 0:None             | O    | 339          | O   | O   | O   | O   | O |
| 85  | 0h1755                | Virtual DI 16  | Communication multi-function input 16 | 15            | 2nd Source    | 0:None             | O    | 339          | O   | O   | O   | O   | O |
|     |                       |                |                                       | 16            | Exchange      | 0:None             | O    | -            | O   | O   | O   | O   | O |
|     |                       |                |                                       | 17/18         | Up/Down       |                    |      |              |     |     |     |     |   |
|     |                       |                |                                       | 19            | Reserved      |                    |      |              |     |     |     |     |   |
|     |                       |                |                                       | 20            | U/D Clear     |                    |      |              |     |     |     |     |   |
|     |                       |                |                                       | 21            | Analog Hold   |                    |      |              |     |     |     |     |   |

| No. | Communication Address | LCD Display    | Name  | Setting Range |               | Initial Value | Shift in Operation | Page | Control Mode |     |     |       |       |   |   |   |   |   |   |
|-----|-----------------------|----------------|---|---------------|---------------|---------------|--------------------|------|--------------|-----|-----|-------|-------|---|---|---|---|---|---|
|     |                       |                |   |               |               |               |                    |      | V / F        | S L | V C | S L T | V C T |   |   |   |   |   |   |
|     |                       |                |   | 22            | I-Term Clear  |               |                    |      |              |     |     |       |       |   |   |   |   |   |   |
|     |                       |                |   | 23            | PID Openloop  |               |                    |      |              |     |     |       |       |   |   |   |   |   |   |
|     |                       |                |   | 24            | P Gain2       |               |                    |      |              |     |     |       |       |   |   |   |   |   |   |
|     |                       |                |   | 25            | XCEL Stop     |               |                    |      |              |     |     |       |       |   |   |   |   |   |   |
|     |                       |                |   | 26            | 2nd Motor     |               |                    |      |              |     |     |       |       |   |   |   |   |   |   |
|     |                       |                |   | 27            | Trv Offset Lo |               |                    |      |              |     |     |       |       |   |   |   |   |   |   |
|     |                       |                |   | 28            | Trv Offset Hi |               |                    |      |              |     |     |       |       |   |   |   |   |   |   |
|     |                       |                |   | 29            | Interlock 1   |               |                    |      |              |     |     |       |       |   |   |   |   |   |   |
|     |                       |                |   | 30            | Interlock 2   |               |                    |      |              |     |     |       |       |   |   |   |   |   |   |
|     |                       |                |   | 31            | Interlock 3   |               |                    |      |              |     |     |       |       |   |   |   |   |   |   |
|     |                       |                |   | 32            | Interlock 4   |               |                    |      |              |     |     |       |       |   |   |   |   |   |   |
|     |                       |                |   | 33            | Reserved      |               |                    |      |              |     |     |       |       |   |   |   |   |   |   |
|     |                       |                |   | 34            | Pre Excite    |               |                    |      |              |     |     |       |       |   |   |   |   |   |   |
|     |                       |                |   | 35            | Speed/Torque  |               |                    |      |              |     |     |       |       |   |   |   |   |   |   |
|     |                       |                |   | 36            | ASR Gain 2    |               |                    |      |              |     |     |       |       |   |   |   |   |   |   |
|     |                       |                |   | 37            | ASR P/PI      |               |                    |      |              |     |     |       |       |   |   |   |   |   |   |
|     |                       |                |   | 38            | Timer In      |               |                    |      |              |     |     |       |       |   |   |   |   |   |   |
|     |                       |                |   | 39            | Thermal In    |               |                    |      |              |     |     |       |       |   |   |   |   |   |   |
|     |                       |                |   | 40            | Dis Aux Ref   |               |                    |      |              |     |     |       |       |   |   |   |   |   |   |
|     |                       |                |   | 41            | -Reserved-    |               |                    |      |              |     |     |       |       |   |   |   |   |   |   |
|     |                       |                |   | 42            | -Reserved-    |               |                    |      |              |     |     |       |       |   |   |   |   |   |   |
|     |                       |                |   | 43            | -Reserved-    |               |                    |      |              |     |     |       |       |   |   |   |   |   |   |
|     |                       |                |   | 44            | -Reserved-    |               |                    |      |              |     |     |       |       |   |   |   |   |   |   |
|     |                       |                |   | 45            | -Reserved-    |               |                    |      |              |     |     |       |       |   |   |   |   |   |   |
|     |                       |                |   | 46            | FWD JOG       |               |                    |      |              |     |     |       |       |   |   |   |   |   |   |
|     |                       |                |   | 47            | REV JOG       |               |                    |      |              |     |     |       |       |   |   |   |   |   |   |
|     |                       |                |   | 48            | Trq Bias      |               |                    |      |              |     |     |       |       |   |   |   |   |   |   |
|     |                       |                |   | 49            | XCEL-H        |               |                    |      |              |     |     |       |       |   |   |   |   |   |   |
|     |                       |                |   | 50            | KEB Select    |               |                    |      |              |     |     |       |       |   |   |   |   |   |   |
|     |                       |                |   | 51            | Fire Mode     |               |                    |      |              |     |     |       |       |   |   |   |   |   |   |
| 86  | 0h1756                | Virt DI Status | Communication multi-function input monitoring | -             | -             | 0             | X                  | 339  | O            | O   | O   | O     | O     | O | O | O | O | O | O |
| 90  | 0h175A                | Comm Mon Sel   | Monitor type selection                        | 0             | Int 485       | 0:            | O                  | 341  | O            | O   | O   | O     | O     | O | O | O | O | O | O |
|     |                       |                |   | 1             | Keypad        | Int 485       |                    |      |              |     |     |       |       |   |   |   |   |   |   |
| 91  | 0h175B                | RcvFrame Num   | Number of reception frames                    | -             | -             | 0             | -                  | 341  | O            | O   | O   | O     | O     | O | O | O | O | O | O |
| 92  | 0h175C                | Err Frame Num  | Number of error frames                        | -             | -             | 0             | -                  | 341  | O            | O   | O   | O     | O     | O | O | O | O | O | O |
| 93  | 0h175D                | Nak Frame Num  | Number of writing error frames                | -             | -             | 0             | -                  | 341  | O            | O   | O   | O     | O     | O | O | O | O | O | O |
| 94  | 0h175E                | Comm Update    | Communication update                          | 0             | No            | 0             | -                  | 341  | O            | O   | O   | O     | O     | O | O | O | O | O | O |
|     |                       |                |   | 1             | Yes           |               |                    |      |              |     |     |       |       |   |   |   |   |   |   |

note29-2) COM 94 is displayed when the communication option module is installed.

## 13.8 Parameter Mode – Applied Function Group (→APP)

### Applied Function Group (PAR → APP)

| No.           | Communi-<br>cation<br>Address | LCD Display       | Name                           | Setting Range   | Initial<br>Value | Shift in<br>Opera-<br>tion | Page | Control Mode |        |        |             |             |   |
|---------------|-------------------------------|-------------------|--------------------------------|-----------------|------------------|----------------------------|------|--------------|--------|--------|-------------|-------------|---|
|               |                               |                   |                                |                 |                  |                            |      | V<br>/<br>F  | S<br>L | V<br>C | S<br>L<br>T | V<br>C<br>T |   |
| 00            | -                             | Jump Code         | Jump code                      | 0-99            | 20               | O                          | -    | O            | O      | O      | O           | O           |   |
| 01            | 0h1801                        | App Mode          | Applied function selection     | 0               | None             | 0:<br>None                 | X    | -            | O      | O      | O           | X           | X |
|               |                               |                   |                                | 1               | Traverse         |                            |      |              |        |        |             |             |   |
|               |                               |                   |                                | 2               | Proc PID         |                            |      |              |        |        |             |             |   |
|               |                               |                   |                                | 3               | Reserved         |                            |      |              |        |        |             |             |   |
|               |                               |                   |                                | 4               | Auto<br>Sequence |                            |      |              |        |        |             |             |   |
| 08<br>Note30) | 0h1808                        | Trv Aplmit %      | Traverse operating range       | 0-20 (%)        | 0.0              | O                          | 266  | O            | O      | O      | X           | X           |   |
| 09            | 0h1809                        | Trv Scramb %      | Traverse scramble<br>magnitude | 0-50 (%)        | 0.0              | O                          | 266  | O            | O      | O      | X           | X           |   |
| 10            | 0h180A                        | Trv Acc Time      | Traverse acceleration time     | 0.1-600.0 (sec) | 2.0              | O                          | 266  | O            | O      | O      | X           | X           |   |
| 11            | 0h180B                        | Trv Dec Time      | Traverse deceleration time     | 0.1-600.0 (sec) | 3.0              | O                          | 266  | O            | O      | O      | X           | X           |   |
| 12            | 0h180C                        | Trv Offset Hi     | Traverse offset upper limit    | 0-20.0 (%)      | 0.0              | O                          | 266  | O            | O      | O      | X           | X           |   |
| 13            | 0h180D                        | Trv Offset lo     | Traverse offset lower limit    | 0-20.0 (%)      | 0.0              | O                          | 266  | O            | O      | O      | X           | X           |   |
| 16<br>Note31) | 0h1810                        | PID Output        | PID output monitor             | (%)             | 0.00             | -                          | 213  | O            | O      | O      | X           | X           |   |
| 17            | 0h1811                        | PID Ref Value     | PID reference monitor          | (%)             | 50.00            | -                          | 213  | O            | O      | O      | X           | X           |   |
| 18            | 0h1812                        | PID Fdb Value     | PID feedback monitor           | (%)             | 0.00             | -                          | 213  | O            | O      | O      | X           | X           |   |
| 19            | 0h1813                        | PID Ref Set       | PID reference setting          | -100-100 (%)    | 50%              | O                          | 213  | O            | O      | O      | X           | X           |   |
| 20            | 0h1814                        | PID<br>Ref Source | PID reference selection        | 0               | Keypad           | 0:Key<br>pad               | X    | 213          | O      | O      | O           | X           | X |
|               |                               |                   |                                | 1               | V1               |                            |      |              |        |        |             |             |   |
|               |                               |                   |                                | 2               | I1               |                            |      |              |        |        |             |             |   |
|               |                               |                   |                                | 3               | V2               |                            |      |              |        |        |             |             |   |
|               |                               |                   |                                | 4               | I2               |                            |      |              |        |        |             |             |   |
|               |                               |                   |                                | 5               | Int 485          |                            |      |              |        |        |             |             |   |
|               |                               |                   |                                | 6               | Encoder          |                            |      |              |        |        |             |             |   |
|               |                               |                   |                                | 7               | FieldBus         |                            |      |              |        |        |             |             |   |
|               |                               |                   |                                | 8               | PLC              |                            |      |              |        |        |             |             |   |
|               |                               |                   |                                | 9               | Synchro          |                            |      |              |        |        |             |             |   |
|               |                               |                   |                                | 10              | Binary Type      |                            |      |              |        |        |             |             |   |

\*  The grey cells indicate a hidden code which is only visible when setting a code.

Note 30) APP 08-13 codes are displayed only when APP-01 (App Mode) is set as "Traverse".

Note 31) APP 16-45 codes are displayed only when APP-01 (App Mode) is set as "Proc PID" or APP-01(App Mode) is set as "MMC" and Reql Bypass (APO-34) is set as "No".

## Applied Function Group (PAR → APP)

| No. | Communication Address | LCD Display    | Name                                   | Setting Range                           | Initial Value | Shift in Operation | Page | Control Mode |     |     |       |       |   |
|-----|-----------------------|----------------|--|---|---------------|--------------------|------|--------------|-----|-----|-------|-------|---|
|     |                       |                |  |   |               |                    |      | V/F          | S/L | V/C | S/L/T | V/C/T |   |
| 21  | 0h1815                | PID F/B Source | PID feedback selection                 | 0                                       | V1            | 0:V1               | X    | 213          | O   | O   | O     | X     | X |
|     |                       |                |  | 1                                       | I1            |                    |      |              |     |     |       |       |   |
|     |                       |                |  | 2                                       | V2            |                    |      |              |     |     |       |       |   |
|     |                       |                |  | 3                                       | I2            |                    |      |              |     |     |       |       |   |
|     |                       |                |  | 4                                       | Int 485       |                    |      |              |     |     |       |       |   |
|     |                       |                |  | 5                                       | Encoder       |                    |      |              |     |     |       |       |   |
|     |                       |                |  | 6                                       | FieldBus      |                    |      |              |     |     |       |       |   |
|     |                       |                |  | 7                                       | PLC           |                    |      |              |     |     |       |       |   |
|     |                       |                |  | 8                                       | Synchro       |                    |      |              |     |     |       |       |   |
|     |                       |                | 9                                      | Binary Type                             |               |                    |      |              |     |     |       |       |   |
| 22  | 0h1816                | PID P-Gain     | PID proportional gain                  | 0-1000 (%)                              | 50.0          | O                  | 213  | O            | O   | O   | X     | X     |   |
| 23  | 0h1817                | PID I-Time     | PID integral time                      | 0-200.0 (sec)                           | 10.0          | O                  | 213  | O            | O   | O   | X     | X     |   |
| 24  | 0h1818                | PID D-Time     | PID differential time                  | 0-1000 (ms)                             | 0             | O                  | 213  | O            | O   | O   | X     | X     |   |
| 25  | 0h1819                | PID F-Gain     | PID feed forward gain                  | 0-1000.0 (%)                            | 0.0           | O                  | 213  | O            | O   | O   | X     | X     |   |
| 26  | 0h181A                | P Gain Scale   | Proportional gain scale                | 0-100.0 (%)                             | 100.0         | X                  | 213  | O            | O   | O   | X     | X     |   |
| 27  | 0h181B                | PID Out LPF    | PID output filter                      | 0-10000 (ms)                            | 0             | O                  | 213  | O            | O   | O   | X     | X     |   |
| 28  | 0h181C                | PID Mode       | PID mode select                        | 0                                       | Process PID   | 0:Process PID      | 212  | 213          | O   | O   | O     | X     | X |
|     |                       |                |  | 1                                       | Normal PID    |                    |      |              |     |     |       |       |   |
| 29  | 0h181D                | PID Limit Hi   | PID upper limit frequency              | PID lower limit frequency (Hz)-300 (Hz) |               | 60.00              | O    | 213          | O   | O   | O     | X     | X |
|     |                       |                |  | -300-PID upper limit frequency (Hz)     |               |                    |      |              |     |     |       |       |   |
| 30  | 0h181E                | PID Limit Lo   | PID lower limit frequency              | -300-PID upper limit frequency (Hz)     |               | -60.00             | O    | 213          | O   | O   | O     | X     | X |
| 31  | 0h181F                | PID Out Inv    | PID output inverse                     | 0                                       | No            | 0:No               | 212  | 213          | O   | O   | O     | X     | X |
|     |                       |                |  | 1                                       | Yes           |                    |      |              |     |     |       |       |   |
| 32  | 0h1820                | PID Out Scale  | PID output scale                       | 0.1-1000 (%)                            | 100.0         | X                  | 213  | O            | O   | O   | X     | X     |   |
| 34  | 0h1822                | Pre-PID Freq   | PID control period movement frequency  | 0-maximum frequency (Hz)                | 0.00          | X                  | 213  | O            | O   | O   | X     | X     |   |
| 35  | 0h1823                | Pre-PID Exit   | PID control period movement level      | 0-100 (%)                               | 0.0           | X                  | 213  | O            | O   | O   | X     | X     |   |
| 36  | 0h1824                | Pre-PID Delay  | PID control period movement delay time | 0-9999 (sec)                            | 600           | O                  | 213  | O            | O   | O   | X     | X     |   |
| 37  | 0h1825                | PID Sleep DT   | PID sleep mode delay time              | 0-999.9 (sec)                           | 60.0          | O                  | 213  | O            | O   | O   | X     | X     |   |
| 38  | 0h1826                | PID Sleep Freq | PID sleep mode frequency               | 0-maximum frequency (Hz)                | 0.00          | O                  | 213  | O            | O   | O   | X     | X     |   |
| 39  | 0h1827                | PID WakeUp Lev | PID wake up level                      | 0-100 (%)                               | 35            | O                  | 213  | O            | O   | O   | X     | X     |   |
| 40  | 0h1828                | PID WakeUp Mod | PID wake up mode setting               | 0                                       | Below Level   | 0:Below Level      | O    | 213          | O   | O   | O     | X     | X |
|     |                       |                |  | 1                                       | Above Level   |                    |      |              |     |     |       |       |   |
|     |                       |                |  | 2                                       | Beyond Level  |                    |      |              |     |     |       |       |   |
| 41  | 0h1829                | PID Rev Run En | PID reverse operation                  | 0                                       | No            | 0:No               | X    | 213          | O   | O   | O     | X     | X |
|     |                       |                |  | 1                                       | Yes           |                    |      |              |     |     |       |       |   |
| 42  |                       |                |  | 0                                       | %             | 0:%                | O    | 213          | O   | O   | O     | X     | X |
|     |                       |                |  | 1                                       | Bar           |                    |      |              |     |     |       |       |   |
|     |                       |                |  | 2                                       | mBar          |                    |      |              |     |     |       |       |   |
|     |                       |                |  | 3                                       | Pa            |                    |      |              |     |     |       |       |   |

## Table of Functions

| No. | Communi-<br>cation<br>Address | LCD Display       | Name                                  | Setting Range | Initial Value | Shift in<br>Opera-<br>tion | Page | Control Mode |        |        |             |             |  |  |
|-----|-------------------------------|-------------------|---------------------------------------|---------------|---------------|----------------------------|------|--------------|--------|--------|-------------|-------------|--|--|
|     |                               |                   |                                       |               |               |                            |      | V<br>/<br>F  | S<br>L | V<br>C | S<br>L<br>T | V<br>C<br>T |  |  |
|     |                               |                   |                                       | 4   KPa       |               |                            |      |              |        |        |             |             |  |  |
|     |                               |                   |                                       | 5   Hz        |               |                            |      |              |        |        |             |             |  |  |
|     |                               |                   |                                       | 6   rpm       |               |                            |      |              |        |        |             |             |  |  |
|     |                               |                   |                                       | 7   V         |               |                            |      |              |        |        |             |             |  |  |
|     |                               |                   |                                       | 8   I         |               |                            |      |              |        |        |             |             |  |  |
|     |                               |                   |                                       | 9   kW        |               |                            |      |              |        |        |             |             |  |  |
|     |                               |                   |                                       | 10   HP       |               |                            |      |              |        |        |             |             |  |  |
|     |                               |                   |                                       | 11   °C       |               |                            |      |              |        |        |             |             |  |  |
|     |                               |                   |                                       | 12   °F       |               |                            |      |              |        |        |             |             |  |  |
| 43  | 0h182B                        | PID Unit Gain     | PID unit gain                         | 0-300 (%)     | 100.00        | O                          | 213  | O            | O      | O      | X           | X           |  |  |
| 44  | 0h182C                        | PID Unit<br>Scale | PID unit scale                        | 0   X 0.01    | 2x 1          | O                          | 213  | O            | O      | O      | X           | X           |  |  |
|     |                               |                   |                                       | 1   X 0.1     |               |                            |      |              |        |        |             |             |  |  |
|     |                               |                   |                                       | 2   X 1       |               |                            |      |              |        |        |             |             |  |  |
|     |                               |                   |                                       | 3   X 0.1     |               |                            |      |              |        |        |             |             |  |  |
|     |                               |                   |                                       | 4   X 0.01    |               |                            |      |              |        |        |             |             |  |  |
| 45  | 0h182D                        | PID P2-Gain       | PID 2 <sup>nd</sup> proportional gain | 0-1000 (%)    | 100.0         | X                          | 213  | O            | O      | O      | X           | X           |  |  |

Note<sup>31)</sup> APP 16-45 codes are displayed only when APP-01 (App Mode) is set as "Proc PID" or APP-01(App Mode) is set as "MMC" and Reql Bypass (APO-34) is set as "No".

## 13.9 Parameter Mode – Option Module Function Group (→APO)

### Option Module Function Group (PAR → APO)

| No.                          | Communi-<br>cation<br>Address | LCD Display      | Name   | Setting Range | Initial<br>Value | Shift in<br>Opera-<br>tion | Page | Control Mode |        |        |             |             |
|------------------------------|-------------------------------|------------------|--|---------------|------------------|----------------------------|------|--------------|--------|--------|-------------|-------------|
|                              |                               |                  |  |               |                  |                            |      | V<br>/<br>F  | S<br>L | V<br>C | S<br>L<br>T | V<br>C<br>T |
| 00                           | -                             | Jump Code        | Jump code  | 0-99          | 20               | O                          |      | O            | O      | O      | O           | O           |
| 01<br><small>Note37)</small> | 0h1A01                        | Enc<br>Opt Mode  | Encoder function item                                | 0             | None             | 0:None                     | O    | 150          | O      | O      | O           | O           |
|                              |                               |                  |  | 1             | Feedback         |                            |      |              |        |        |             |             |
|                              |                               |                  |  | 2             | Reference        |                            |      |              |        |        |             |             |
| 04                           | 0h1A04                        | Enc<br>Type Sel  | Encoder type selection                               | 0             | Line Driver      | 0:Line<br>Driver           | X    | 150          | O      | O      | O           | O           |
|                              |                               |                  |  | 1             | Totem or<br>Com  |                            |      |              |        |        |             |             |
|                              |                               |                  |  | 2             | Open Collector   |                            |      |              |        |        |             |             |
| 05                           | 0h1A05                        | Enc<br>Pulse Sel | Encoder pulse<br>direction                           | 0             | (A+B)            | 0:<br>(A+B)                | X    | 150          | O      | O      | O           | O           |
|                              |                               |                  |  | 1             | -(A+B)           |                            |      |              |        |        |             |             |
|                              |                               |                  |  | 2             | A                |                            |      |              |        |        |             |             |
| 06                           | 0h1A06                        | Enc<br>Pulse Num | Number of encoder<br>pulses                          | 10-5000       | 1024             | X                          | 150  | O            | O      | O      | O           |             |
| 08                           | 0h1A08                        | Enc Monitor      | Feedback monitor                                     | -             | -                | O                          | 150  | O            | O      | O      | O           |             |
| 09                           | 0h1A09                        | Pulse Monitor    | Reference monitor                                    | -             | -                | O                          | 150  | O            | O      | O      | O           |             |
| 10                           | 0h1A0A                        | Enc Filter       | Encoder input filter                                 | 0-10000 (ms)  | 3                | O                          | 150  | O            | O      | O      | O           |             |
| 11                           | 0h1A0B                        | Enc Pulse x1     | Encoder minimum<br>input pulse                       | 0-100 (kHz)   | 0.0              | O                          | 150  | O            | X      | O      | X           |             |
| 12                           | 0h1A0C                        | Enc Perc y1      | Output at encoder<br>minimum pulse (%)               | 0-100 (%)     | 0.00             | O                          | 150  | O            | X      | O      | X           |             |
| 13                           | 0h1A0D                        | Enc Pulse x2     | Encoder maximum<br>input pulse                       | 0-200 (kHz)   | 100              | O                          | 150  | O            | X      | O      | X           |             |
| 14                           | 0h1A0E                        | Enc Perc y2      | Encoder maximum<br>pulse output (%)                  | 0-100 (%)     | 100              | O                          | 150  | O            | X      | O      | X           |             |
| 20<br><small>Note38)</small> | 0h1A14                        | Aux Motor Run    | Display of number of<br>auxiliary motor<br>movements | 0-4           | 0                | O                          | 270  | O            | O      | O      | X           | X           |
| 21                           | 0h1A15                        | Starting Aux     | Starting auxiliary motor<br>selection                | 1-4           | 1                | X                          | 270  | O            | O      | O      | X           | X           |
| 22                           | 0h1A16                        | AutoOp Time      | Auto change operation<br>time                        | X:XX (Min)    | 0:00             | O                          | 270  | O            | O      | O      | X           | X           |
| 23                           | 0h1A17                        | Start Freq 1     | 1st auxiliary motor<br>starting frequency            | 0-60 (Hz)     | 49.99            | O                          | 270  | O            | O      | O      | X           | X           |
| 24                           | 0h1A18                        | Start Freq 2     | 2nd auxiliary motor<br>starting frequency            | 0-60 (Hz)     | 49.99            | O                          | 270  | O            | O      | O      | X           | X           |
| 25                           | 0h1A19                        | Start Freq 3     | 3rd auxiliary motor<br>starting frequency            | 0-60 (Hz)     | 49.99            | O                          | 270  | O            | O      | O      | X           | X           |
| 26                           | 0h1A1A                        | Start Freq 4     | 4th auxiliary motor<br>starting frequency            | 0-60 (Hz)     | 49.99            | O                          | 270  | O            | O      | O      | X           | X           |

## Table of Functions

| No.           | Communication Address | LCD Display    | Name  | Setting Range   | Initial Value | Shift in Operation | Page   | Control Mode |     |     |       |       |   |
|---------------|-----------------------|----------------|---|-----------------|---------------|--------------------|--------|--------------|-----|-----|-------|-------|---|
|               |                       |                |   |                 |               |                    |        | V / F        | S L | V C | S L T | V C T |   |
| 27            | 0h1A1B                | Stop Freq 1    | 1st auxiliary motor stop frequency                          | 0-60 (Hz)       | 15.00         | O                  | 270    | O            | O   | O   | X     | X     |   |
| 28            | 0h1A1C                | Stop Freq 2    | 2nd auxiliary motor stop frequency                          | 0-60 (Hz)       | 15.00         | O                  | 270    | O            | O   | O   | X     | X     |   |
| 29            | 0h1A1D                | Stop Freq 3    | 3rd auxiliary motor stop frequency                          | 0-60 (Hz)       | 15.00         | O                  | 270    | O            | O   | O   | X     | X     |   |
| 30            | 0h1A1E                | Stop Freq 4    | 4th auxiliary motor stop frequency                          | 0-60 (Hz)       | 15.00         | O                  | 270    | O            | O   | O   | X     | X     |   |
| 31            | 0h1A1F                | Aux Start DT   | Auxiliary motor starting delay time                         | 0-3600.0 (sec)  | 60.0          | O                  | 270    | O            | O   | O   | X     | X     |   |
| 32            | 0h1A20                | Aux Stop DT    | Auxiliary motor stop delay time                             | 0-3600.0 (sec)  | 60.0          | O                  | 270    | O            | O   | O   | X     | X     |   |
| 33            | 0h1A21                | Num of Aux     | Auxiliary motor number selection                            | 0-4             | 4             | X                  | 270    | O            | O   | O   | X     | X     |   |
| 34            | 0h1A22                | Regul Bypass   | Bypass selection  | 0               | No            | 0:No               | X      | 270          | O   | O   | O     | X     | X |
|               |                       |                |   | 1               | Yes           |                    |        |              |     |     |       |       |   |
| 35            | 0h1A23                | Auto Ch Mode   | Auto change mode selection                                  | 0               | None          | 1: Aux             | X      | 270          | O   | O   | O     | X     | X |
|               |                       |                |   | 1               | Aux           |                    |        |              |     |     |       |       |   |
|               |                       |                |   | 2               | Main          |                    |        |              |     |     |       |       |   |
| 36            | 0h1A24                | Auto Ch Time   | Auto change time  | 0-99:00 (min)   | 72:00         | O                  | 270    | O            | O   | O   | X     | X     |   |
| 38            | 0h1A26                | Interlock      | Interlock selection   | 0               | No            | 0:No               | O      | 270          | O   | O   | O     | X     | X |
|               |                       |                |   | 1               | Yes           |                    |        |              |     |     |       |       |   |
| 39            | 0h1A27                | Interlock DT   | Interlock movement delay time                               | 0.1-360.0 (sec) | 5.0           | O                  | 270    | O            | O   | O   | X     | X     |   |
| 40            | 0h1A28                | Actual Pr Diff | Auxiliary motor movement pressure difference                | 0-100 (%)       | 2             | O                  | 270    | O            | O   | O   | X     | X     |   |
| 41            | 0h1A29                | Aux Acc Time   | Main motor acceleration time when number of pumps decreases | 0-600.0 (sec)   | 2.0           | O                  | 270    | O            | O   | O   | X     | X     |   |
| 42            | 0h1A2A                | Aux Dec Time   | Main motor deceleration time when number of pumps increases | 0-600.0 (sec)   | 2.0           | O                  | 270    | O            | O   | O   | X     | X     |   |
| 58<br>Note39) | 0h1A3A                | PLC LED Status | PLC option LED status                                       | -               | -             | O                  | Option | O            | O   | O   | O     | O     |   |
| 59            | 0h1A3B                | PLC S/W Ver    | PLC option module S/W version                               | -               | 1.X           | O                  | Option | O            | O   | O   | O     | O     |   |
| 60            | 0h1A3C                | PLC Wr Data 1  | PLC write data 1  | 0-FFFF (Hex)    | 0000          | O                  | Option | O            | O   | O   | O     | O     |   |
| 61            | 0h1A3D                | PLC Wr Data 2  | PLC write data 2  | 0-FFFF (Hex)    | 0000          | O                  | Option | O            | O   | O   | O     | O     |   |
| 62            | 0h1A3E                | PLC Wr Data 3  | PLC write data 3  | 0-FFFF (Hex)    | 0000          | O                  | Option | O            | O   | O   | O     | O     |   |
| 63            | 0h1A3F                | PLC Wr Data 4  | PLC write data 4  | 0-FFFF (Hex)    | 0000          | O                  | Option | O            | O   | O   | O     | O     |   |
| 64            | 0h1A40                | PLC Wr Data 5  | PLC write data 5  | 0-FFFF (Hex)    | 0000          | O                  | Option | O            | O   | O   | O     | O     |   |
| 65            | 0h1A41                | PLC Wr Data 6  | PLC write data 6  | 0-FFFF (Hex)    | 0000          | O                  | Option | O            | O   | O   | O     | O     |   |

| No. | Communi-<br>cation<br>Address | LCD Display   | Name             | Setting Range | Initial<br>Value | Shift in<br>Opera-<br>tion | Page   | Control Mode |        |        |             |             |
|-----|-------------------------------|---------------|------------------|---------------|------------------|----------------------------|--------|--------------|--------|--------|-------------|-------------|
|     |                               |               |                  |               |                  |                            |        | V<br>/<br>F  | S<br>L | V<br>C | S<br>L<br>T | V<br>C<br>T |
| 66  | 0h1A42                        | PLC Wr Data 7 | PLC write data 7 | 0-FFFF (Hex)  | 0000             | O                          | Option | O            | O      | O      | O           | O           |
| 67  | 0h1A43                        | PLC Wr Data 8 | PLC write data 8 | 0-FFFF (Hex)  | 0000             | O                          | Option | O            | O      | O      | O           | O           |
| 76  | 0h1A4C                        | PLC Rd Data 1 | PLC read data 1  | 0-FFFF (Hex)  | 0000             | O                          | Option | O            | O      | O      | O           | O           |
| 77  | 0h1A4D                        | PLC Rd Data 2 | PLC read data 2  | 0-FFFF (Hex)  | 0000             | O                          | Option | O            | O      | O      | O           | O           |
| 78  | 0h1A4E                        | PLC Rd Data 3 | PLC read data 3  | 0-FFFF (Hex)  | 0000             | O                          | Option | O            | O      | O      | O           | O           |
| 79  | 0h1A4F                        | PLC Rd Data 4 | PLC read data 4  | 0-FFFF (Hex)  | 0000             | O                          | Option | O            | O      | O      | O           | O           |
| 80  | 0h1A50                        | PLC Rd Data 5 | PLC read data 5  | 0-FFFF (Hex)  | 0000             | O                          | Option | O            | O      | O      | O           | O           |
| 81  | 0h1A51                        | PLC Rd Data 6 | PLC read data 6  | 0-FFFF (Hex)  | 0000             | O                          | Option | O            | O      | O      | O           | O           |
| 82  | 0h1A52                        | PLC Rd Data 7 | PLC read data 7  | 0-FFFF (Hex)  | 0000             | O                          | Option | O            | O      | O      | O           | O           |
| 83  | 0h1A53                        | PLC Rd Data 8 | PLC read data 8  | 0-FFFF (Hex)  | 0000             | O                          | Option | O            | O      | O      | O           | O           |

\*  The grey cells indicate a hidden code which is only visible when setting a code.

Note 37) APO-01-14 codes are displayed only when the encoder module is installed.

Note 38) APO-20-42 codes are displayed only when APP-01 (App Mode) is set as "MMC".

Note 39) APO-58-83 codes are displayed only when the PLC option module is installed.



## 13.10 Parameter Mode – Protective Function Group (→PRT)

### Protective Function Group (PAR → PRT)

| No.                          | Communication Address | LCD Display    | Name                                      | Setting Range                           | Initial Value | Shift in Operation | Page | Control Mode |       |       |       |       |
|------------------------------|-----------------------|----------------|---|---|---------------|--------------------|------|--------------|-------|-------|-------|-------|
|                              |                       |                |   |   |               |                    |      | V / F        | S / L | V / C | S / L | V / C |
| 00                           | -                     | Jump Code      | Jump code                                 | 0-99                                    | 40            | O                  |      | O            | O     | O     | O     | O     |
| 04                           | 0h1B04                | Load Duty      | Load amount setting                       | 0 Normal Duty                           | 1:Heavy Duty  | X                  | 310  | O            | O     | O     | O     | O     |
|                              |                       |                |   | 1 Heavy Duty                            |               |                    |      |              |       |       |       |       |
| 05                           | 0h1B05                | Phase Loss Chk | Input/output open-phase protection        | Bit 00-11                               | 00            | X                  | 317  | O            | O     | O     | O     | O     |
|                              |                       |                |   | 1 Output open phase                     |               |                    |      |              |       |       |       |       |
|                              |                       |                |   | 2 Input open phase                      |               |                    |      |              |       |       |       |       |
| 06                           | 0h1B06                | IPO V Band     | Input voltage range during open-phase     | 1-100 (V)                               | 40            | X                  | 317  | O            | O     | O     | O     | O     |
| 07                           | 0h1B07                | Trip Dec Time  | Deceleration time at fault trip           | 0-600 (sec)                             | 3.0           | O                  | 319  | O            | O     | O     | O     | O     |
| 08                           | 0h1B08                | RST Restart    | Starting selection on trip reset          | 0 No                                    | 0:No          | O                  | 247  | O            | O     | O     | O     | O     |
|                              |                       |                |   | 1 Yes                                   |               |                    |      |              |       |       |       |       |
| 09                           | 0h1B09                | Retry Number   | Number of automatic restarts              | 0-10                                    | 0             | O                  | 247  | O            | O     | O     | O     | O     |
| 10<br><small>Note40)</small> | 0h1B0A                | Retry Delay    | Automatic restart delay time              | 0-60.0 (sec)                            | 1.0           | O                  | 247  | O            | O     | O     | O     | O     |
| 11                           | 0h1B0B                | Lost KPD Mode  | Keypad command loss operation mode        | 0 None                                  | 0:None        | O                  | 319  | O            | O     | O     | O     | O     |
|                              |                       |                |   | 1 Warning                               |               |                    |      |              |       |       |       |       |
|                              |                       |                |   | 2 Free-Run                              |               |                    |      |              |       |       |       |       |
|                              |                       |                |   | 3 Dec                                   |               |                    |      |              |       |       |       |       |
| 12                           | 0h1B0C                | Lost Cmd Mode  | Speed command loss operation mode         | 0 None                                  | 0:None        | O                  | 321  | O            | O     | O     | O     | O     |
|                              |                       |                |   | 1 Free-Run                              |               |                    |      |              |       |       |       |       |
|                              |                       |                |   | 2 Dec                                   |               |                    |      |              |       |       |       |       |
|                              |                       |                |   | 3 Hold Input                            |               |                    |      |              |       |       |       |       |
|                              |                       |                |   | 4 Hold Output                           |               |                    |      |              |       |       |       |       |
| 5 Lost Preset                |                       |                |   |   |               |                    |      |              |       |       |       |       |
| 13<br><small>Note41)</small> | 0h1B0D                | Lost Cmd Time  | Speed command loss judgment time          | 0.0-120 (sec)                           | 1.0           | O                  | 321  | O            | O     | O     | O     | O     |
| 14                           | 0h1B0E                | Lost Preset F  | Operation frequency at speed command loss | Start frequency -maximum frequency (Hz) | 0.00          | O                  | 321  | O            | O     | O     | O     | O     |
| 15                           | 0h1B0F                | AI Lost Level  | Analog input loss judgment level          | 0 Half of x1                            | 0:Half of x1  | O                  | 321  | O            | O     | O     | O     | O     |
|                              |                       |                |   | 1 Below x1                              |               |                    |      |              |       |       |       |       |
| 17                           | 0h1B11                | OL Warn Select | Overload alarm selection                  | 0 No                                    | 0:No          | O                  | 310  | O            | O     | O     | O     | O     |
|                              |                       |                |   | 1 Yes                                   |               |                    |      |              |       |       |       |       |
| 18                           | 0h1B12                | OL Warn Level  | Overload alarm level                      | 30-180 (%)                              | 150           | O                  | 310  | O            | O     | O     | O     | O     |
| 19                           | 0h1B13                | OL Warn Time   | Overload alarm time                       | 0-30.0 (sec)                            | 10.0          | O                  | 310  | O            | O     | O     | O     | O     |
| 20                           | 0h1B14                | OL Trip Select | Motion at overload trip                   | 0 None                                  | 1:Free-Run    | O                  | 310  | O            | O     | O     | O     | O     |
|                              |                       |                |   | 1 Free-Run                              |               |                    |      |              |       |       |       |       |
|                              |                       |                |   | 2 Dec                                   |               |                    |      |              |       |       |       |       |

### Protective Function Group (PAR → PRT)

| No. | Communication Address | LCD Display | Name | Setting Range | Initial Value | Shift in Operation | Page | Control Mode |       |       |       |       |
|-----|-----------------------|-------------|------|---------------|---------------|--------------------|------|--------------|-------|-------|-------|-------|
|     |                       |             |      |               |               |                    |      | V / F        | S / L | V / C | S / L | V / C |

## Table of Functions

| No.           | Communi- | LCD Display    | Name   | Setting Range                          | Initial         | Shift in       | Page | Control Mode |   |   |   |   |   |
|---------------|----------|----------------|--|--|-----------------|----------------|------|--------------|---|---|---|---|---|
| 21            | 0h1B15   | OL Trip Level  | Overload trip level                                | 30–200 (%)                             | 180             | O              | 310  | O            | O | O | O | O | O |
| 22            | 0h1B16   | OL Trip Time   | Overload trip time                                 | 0–60 (sec)                             | 60.0            | O              | 310  | O            | O | O | O | O | O |
| 25            | 0h1B19   | UL Warn Sel    | Under load alarm selection                         | 0 No<br>1 Yes                          | 0:No            | O              | 324  | O            | O | O | O | O | O |
| 26            | 0h1B1A   | UL Warn Time   | Under load alarm time                              | 0–600.0 (sec)                          | 10.0            | O              | 324  | O            | O | O | O | O | O |
| 27            | 0h1B1B   | UL Trip Sel    | Under load trip selection                          | 0 None<br>1 Free-Run<br>2 Dec          | 0:None          | O              | 324  | O            | O | O | O | O | O |
| 28            | 0h1B1C   | UL Trip Time   | Under load trip time                               | 0–600 (sec)                            | 30.0            | O              | 324  | O            | O | O | O | O | O |
| 29            | 0h1B1D   | UL LF Level    | Under load lower limit level                       | 10–30 (%)                              | 30              | O              | 324  | O            | O | O | O | O | O |
| 30            | 0h1B1E   | UL BF Level    | Under load upper limit level                       | 10–100 (%)                             | 30              | O              | 324  | O            | O | O | O | O | O |
| 31            | 0h1B1F   | No Motor Trip  | Operation on no motor trip                         | 0 None<br>1 Free-Run                   | 0: None         | O              | 330  | O            | O | O | O | O | O |
| 32<br>Note42) | 0h1B20   | No Motor Level | No motor detection current level                   | 1–100 (%)                              | 5               | O              | 330  | O            | O | O | O | O | O |
| 33            | 0h1B21   | No Motor Time  | No motor detection delay                           | 0.1–10.0 (sec)                         | 3.0             | O              | 330  | O            | O | O | O | O | O |
| 34            | 0h1B22   | Thermal-T Sel  | Operation at motor overheat detection              | 0 None<br>1 Free-Run<br>2 Dec          | 0:None          | O              | 315  | O            | O | O | O | O | O |
| 35            | 0h1B23   | Thermal In Src | Thermal sensor input                               | 0 None<br>1 V1<br>2 I1<br>3 V2<br>4 I2 | 0:None          | X              | 315  | O            | O | O | O | O | O |
| 36            | 0h1B24   | Thermal-T Lev  | Thermal sensor fault level                         | 0–100 (%)                              | 50.0            | O              | 315  |              |   |   |   |   |   |
| 37            | 0h1B25   | Thermal-T Area | Thermal sensor fault area                          | 0 Low<br>1 High                        | 0:Low           | O              | 315  | O            | O | O | O | O | O |
| 40            | 0h1B28   | ETH Trip Sel   | Electronic thermal fault trip prevention selection | 0 None<br>1 Free-Run<br>2 Dec          | 0:None          | O              | 308  | O            | O | O | O | O | O |
| 41            | 0h1B29   | Motor Cooling  | Motor cooling fan type                             | 0 Self-cool<br>1 Forced-cool           | 0:Self-cool     | O              | 308  | O            | O | O | O | O | O |
| 42            | 0h1B2A   | ETH 1min       | Electronic thermal one minute rating               | 120–200 (%)                            | 150             | O              | 308  | O            | O | O | O | O | O |
| 43            | 0h1B2B   | ETH Cont       | Electronic thermal prevention continuous rating    | 50–200 (%)                             | 120             | O              | 308  | O            | O | O | O | O | O |
| 45            | 0h1B2D   | BX Mode        | BX mode select                                     | 0 (sec)<br>0.1–600.0 (sec)             | Free-run<br>Dec | 0.0 (Free-run) | O    | 328          | O | O | O | X | X |

Function Table

# Table of Functions

## Protective Function Group (PAR → PRT)

| No. | Communication Address | LCD Display    | Name  | Setting Range                             | Initial Value | Shift in Operation | Page | Control Mode |     |     |       |       |
|-----|-----------------------|----------------|---|---|---------------|--------------------|------|--------------|-----|-----|-------|-------|
|     |                       |                |   |   |               |                    |      | V / F        | S L | V C | S L T | V C T |
| 50  | 0h1B32                | Stall Prevent  | Stall prevention                            | Bit 00000–11111                           | 00000         | X                  | 312  | O            | O   | X   | O     | X     |
|     |                       |                |   | 0 0001 Accelerating (Mode1)               |               |                    |      |              |     |     |       |       |
|     |                       |                |   | 1 0001 Accelerating (Mode2)               |               |                    |      |              |     |     |       |       |
|     |                       |                |   | 0 0010 Steady speed (Mode1)               |               |                    |      |              |     |     |       |       |
|     |                       |                |   | 1 0010 Steady speed (Mode2)               |               |                    |      |              |     |     |       |       |
|     |                       |                |   | # 0100 Decelerating                       |               |                    |      |              |     |     |       |       |
|     |                       |                |   | # 1000 Flux Braking                       |               |                    |      |              |     |     |       |       |
| 51  | 0h1B33                | Stall Freq 1   | Stall frequency 1                           | Start frequency -stall frequency 1 (Hz)   | 60.00         | O                  | 312  | O            | O   | X   | O     | X     |
| 52  | 0h1B34                | Stall Level 1  | Stall level 1                               | 30–250 (%)                                | 180           | X                  | 312  | O            | O   | X   | O     | X     |
| 53  | 0h1B35                | Stall Freq 2   | Stall frequency 2                           | Stall frequency 1 -stall frequency 2 (Hz) | 60.00         | O                  | 312  | O            | O   | X   | O     | X     |
| 54  | 0h1B36                | Stall Level 2  | Stall level 2                               | 30–250 (%)                                | 180           | X                  | 312  | O            | O   | X   | O     | X     |
| 55  | 0h1B37                | Stall Freq 3   | Stall frequency 3                           | Stall frequency 2 -stall frequency 4 (Hz) | 60.00         | O                  | 312  | O            | O   | X   | O     | X     |
| 56  | 0h1B38                | Stall Level 3  | Stall level 3                               | 30–250 (%)                                | 180           | X                  | 312  | O            | O   | X   | O     | X     |
| 57  | 0h1B39                | Stall Freq 4   | Stall frequency 4                           | Stall frequency 3 -maximum frequency (Hz) | 60.00         | O                  | 312  | O            | O   | X   | O     | X     |
| 58  | 0h1B3A                | Stall Level 4  | Stall level 4                               | 30–250 (%)                                | 180           | X                  | 312  | O            | O   | X   | O     | X     |
| 66  | 0h1B42                | DB Wam %ED     | DB resistance warning level                 | 0–30 (%)                                  | 0             | O                  | 322  | O            | O   | O   | O     | O     |
| 70  | 0h1B46                | Over SPD Freq  | Overspeed decision frequency                | 20–130 (%)                                | 120.0         | O                  | 325  | X            | X   | O   | X     | O     |
| 72  | 0h1B48                | Over SPD Time  | Overspeed judgment time                     | 0.01–10.00 (sec)                          | 0.01          | O                  | 325  | X            | X   | O   | X     | O     |
| 73  | 0h1B49                | Speed Dev Trip | Speed error failure                         | 0 No<br>1 Yes                             | 0:No          | O                  | 325  | X            | X   | O   | X     | X     |
| 74  | 0h1B4A                | Speed Dev Band | Speed error width                           | 2-maximum frequency (Hz)                  | 20.00         | O                  | 325  | X            | X   | O   | X     | X     |
| 75  | 0h1B4B                | Speed Dev Time | Speed error judgment time                   | 0.1–1000.0 (sec)                          | 1.0           | O                  | 325  | X            | X   | O   | X     | X     |
| 77  | 0h1B4D                | Enc Wire Check | Encoder option connection check             | 0 No<br>1 Yes                             | 0:No          | O                  | 326  | X            | X   | O   | X     | O     |
| 78  | 0h1B4E                | Enc Check Time | Encoder connection check time               | 0.1–1000.0 (sec)                          | 1.0           | O                  | 326  | X            | X   | O   | X     | O     |
| 79  | 0h1B4F                | FAN Trip Mode  | Cooling fan fault selection                 | 0 Trip<br>1 Warning                       | 1:Warning     | O                  | 327  | O            | O   | O   | O     | O     |
| 80  | 0h1B50                | Opt Trip Mode  | Operation selection on optional module trip | 0 None<br>1 Free-Run<br>2 Dec             | 1:Free-Run    | O                  | 329  | O            | O   | O   | O     | O     |
| 81  | 0h1B51                | LVT Delay      | Low voltage trip decision delay time        | 0–60.0 (sec)                              | 0.0           | X                  | 327  | O            | O   | O   | O     | O     |
| 82  | 0h1B52                | LV2 Enable     | Select 'Low Voltage2' during                | 0 No                                      | 0:No          | X                  | 330  | O            | O   | O   | O     | O     |

| No. | Communi- | LCD Display | Name      | Setting Range | Initial | Shift in | Page | Control Mode |
|-----|----------|-------------|-----------|---------------|---------|----------|------|--------------|
|     |          |             | operation | 1   Yes       |         |          |      |              |

\*  The grey cells indicate a hidden code which is only visible when setting a code.

Note 40) PRT-10 codes are displayed only when PRT-09(Retry Number) is set above "0".

Note 41) PRT-13-15 codes are displayed only when PRT-12(Lost Cmd Mode) is not "None".

Note 42) PRT-32-33 codes are displayed only when PRT-31(No Motor Trip is set as "Free-Run".

## 13.11 Parameter Mode – 2nd Motor Function Group (→M2)

### 2nd Motor Function Group (PAR → M2)

| No. | Communi-<br>cation<br>Address | LCD Display     | Name                                    | Setting Range  | Initial Value                            | Shift in<br>Operation | Page | Control Mode |        |        |             |             |
|-----|-------------------------------|-----------------|---|--|--|-----------------------|------|--------------|--------|--------|-------------|-------------|
|     |                               |                 |   |  |  |                       |      | V<br>/<br>F  | S<br>L | V<br>C | S<br>L<br>T | V<br>C<br>T |
| 00  | -                             | Jump Code       | Jump code                               | 0-99   | 14                                       | O                     | -    | O            | O      | X      | O           | X           |
| 04  | 0h1C04                        | M2-Acc Time     | Acceleration time                       | 0-600 (sec)  | Below 75 kW   20.0<br>Above 90 kW   60.0 | O                     | 251  | O            | O      | X      | O           | X           |
| 05  | 0h1C05                        | M2-Dec Time     | Deceleration time                       | 0-600 (sec)  | Below 75 kW   30.0<br>Above 90 kW   90.0 | O                     | 251  | O            | O      | X      | O           | X           |
| 06  | 0h1C06                        | M2-Capacity     | Motor capacity                          | 0   0.2 kW<br>21   185 kW  | -  | X                     | 251  | O            | O      | X      | O           | X           |
| 07  | 0h1C07                        | M2-Base Freq    | Base frequency                          | 30-400 (Hz)  | 60.00                                    | X                     | 251  | O            | O      | X      | O           | X           |
| 08  | 0h1C08                        | M2-Ctrl Mode    | Control mode                            | 0   V/F<br>1   V/F PG<br>2   Slip Compen<br>3   Sensorless-1<br>4   Sensorless-2 | 0:V/F                                    | X                     | 251  | O            | O      | X      | O           | X           |
| 10  | 0h1C0A                        | M2-Pole Num     | Motor pole                              | 2-48   | Dependent on<br>motor capacity           | X                     | 251  | O            | O      | X      | O           | X           |
| 11  | 0h1C0B                        | M2-Rated Slip   | Rated slip speed                        | 0-3000 (rpm)   |  | X                     | 251  | O            | O      | X      | O           | X           |
| 12  | 0h1C0C                        | M2-Rated Curr   | Motor rated current                     | 1.0-1000.0 (A)   |  | X                     | 251  | O            | O      | X      | O           | X           |
| 13  | 0h1C0D                        | M2-No-load Curr | Motor no-load current                   | 0.5-1000.0 (A)   |  | X                     | 251  | O            | O      | X      | O           | X           |
| 14  | 0h1C0E                        | M2-Rated Volt   | Motor rated voltage                     | 180-480 (V)  |  | X                     | 251  | O            | O      | X      | O           | X           |
| 15  | 0h1C0F                        | M2-Efficiency   | Motor efficiency                        | 70-100 (%)   |  | X                     | 251  | O            | O      | X      | O           | X           |
| 16  | 0h1C10                        | M2-Inertia Rt   | Load inertia ratio                      | 0-8  |  | X                     | 251  |              |        |        |             |             |
| 17  | -                             | M2-Rs           | Stator resistance                       | 0-9.999 (Ω)  |  | X                     | 251  | O            | O      | X      | O           | X           |
| 18  | -                             | M2-Lsigma       | Leak inductance                         | 0-99.99 (mH)   |  | X                     | 251  |              |        |        |             |             |
| 19  | -                             | M2-Ls           | Stator inductance                       | 0-999.9 (mH)   |  | X                     | 251  |              |        |        |             |             |
| 20  | -                             | M2-Tr           | Rotor time constant                     | 25-5000 (ms)   | X  | 251                   | O    | O            | X      | O      | X           |             |
| 25  | 0h1C19                        | M2-V/F Patt     | V/F pattern                             | 0   Linear<br>1   Square<br>2   User V/F   | 0:Linear                                 | X                     | 251  | O            | O      | X      | O           | X           |
| 26  | 0h1C1A                        | M2-Fwd Boost    | Forward torque boost                    | 0-15 (%)   | Below 75 kW: 2.0                         | X                     | 251  | O            | O      | X      | O           | X           |
| 27  | 0h1C1B                        | M2-Rev Boost    | Reverse torque boost                    | 0-15 (%)   | Above 90 kW: 1.0                         | X                     | 251  | O            | O      | X      | O           | X           |
| 28  | 0h1C1C                        | M2-Stall Lev    | Stall prevention level                  | 30-150 (%)   | 150                                      | X                     | 251  | O            | O      | X      | O           | X           |
| 29  | 0h1C1D                        | M2-ETH 1min     | Electronic thermal one<br>minute rating | 100-200 (%)  | 150                                      | X                     | 251  | O            | O      | X      | O           | X           |
| 30  | 0h1C1E                        | M2-ETH Cont     | Electronic thermal<br>continuous rating | 50-150 (%)   | 100                                      | X                     | 251  | O            | O      | X      | O           | X           |
| 40  | 0h1C28                        | M2-             | Revolution display gain                 | 0.1-6000.0 (%)   | 100.0                                    | O                     | 251  | O            | O      | O      | O           | O           |

Function  
Table

## Table of Functions

| No. | Communi- | LCD Display    | Name                     | Setting Range | Initial Value | Shift in | Page | Control Mode |   |   |   |   |   |
|-----|----------|----------------|--------------------------|---------------|---------------|----------|------|--------------|---|---|---|---|---|
|     |          | LoadSpdGain    |                          |               |               |          |      |              |   |   |   |   |   |
| 41  | 0h1C29   | M2-LoadSpdScal | Revolution display scale | 0             | x 1           | 0:x 1    | O    | 251          | O | O | O | O | O |
|     |          |                |                          | 1             | x 0.1         |          |      |              |   |   |   |   |   |
|     |          |                |                          | 2             | x 0.01        |          |      |              |   |   |   |   |   |
|     |          |                |                          | 3             | x 0.001       |          |      |              |   |   |   |   |   |
|     |          |                |                          | 4             | x 0.0001      |          |      |              |   |   |   |   |   |
| 42  | 0h1C2A   | M2-LoadSpdUnit | Revolution display unit  | 0<br>1        | Rpm<br>Mpm    | 0:rpm    | O    | 251          | O | O | O | O | O |

## 13.12 Trip Mode (TRP Current (or Last-x))

### Trip Mode (TRP Last-x)

| No. | LCD Display    | Name                            | Setting Range | Initial Value | Page |     |
|-----|----------------|---------------------------------|---------------|---------------|------|-----|
| 00  | Trip Name ( x) | Trip type display               | -             | -             | 289  |     |
| 01  | Output Freq    | Output frequency at trip        | -             | -             | 289  |     |
| 02  | Output Current | Output current at trip          | -             | -             | 289  |     |
| 03  | Inverter State | Acc/Dec status at trip          | -             | -             | 289  |     |
| 04  | DCLink Voltage | DC voltage                      | -             | -             | 289  |     |
| 05  | Temperature    | NTC temperature                 | -             | -             | 289  |     |
| 06  | DI State       | Status of input terminals       | -             | 0000 0000     | 289  |     |
| 07  | DO State       | Status of output terminals      | -             | 000           | 289  |     |
| 08  | Trip On Time   | Trip time since power on        | -             | 0/00/00 00:00 | 289  |     |
| 09  | Trip Run Time  | Trip time since operation start | -             | 0/00/00 00:00 | 289  |     |
| 10  | Trip Delete    | Delete trip history             | 0             | No            | 0:No | 290 |
|     |                |                                 | 1             | Yes           |      |     |

## 13.13 Config Mode (CNF)

### Config Mode (CNF)

| No. | LCD Display  | Name                      | Setting Range | Initial Value | Page       |     |
|-----|--------------|---------------------------|---------------|---------------|------------|-----|
| 00  | Jump Code    | Jump code                 | 0-99          | 1             | -          |     |
| 01  | Language Sel | Keypad language selection | 0.            | English       | 0. English | 307 |
|     |              |                           | 1.            | Russian       |            |     |
|     |              |                           | 2.            | Español       |            |     |
|     |              |                           | 3.            | Polski        |            |     |
|     |              |                           | 4.            | Turkish       |            |     |
| 02  | LCD Contrast | LCD contrast adjustment   | -             | -             | 264        |     |

| No.             | LCD Display    | Name                        | Setting Range      | Initial Value    | Page   |
|-----------------|----------------|-----------------------------|--------------------|------------------|--------|
| 10              | Inv S/W Ver    | Inverter S/W version        | -                  | 1.XX             | 264    |
| 11              | KeypadS/W Ver  | Keypad S/W version          | -                  | 1.XX             | 264    |
| 12              | KPD Title Ver  | Keypad title version        | -                  | 1.XX             | 264    |
| 20<br>Note43)   | Anytime Para   | Status display              | 0 Frequency        | 0: Frequency     | 288    |
| 21              | Monitor Line-1 | Monitor mode display 1      | 1 Speed            | 0: Frequency     | 284    |
| 22              | Monitor Line-2 | Monitor mode display 2      | 2 Output Current   | 2:Output Current | 284    |
| 23              | Monitor Line-3 | Monitor mode display 3      | 3 Output Voltage   | 3:Output Voltage | 284    |
|                 |                |                             | 4 Output Power     |                  |        |
|                 |                |                             | 5 WHour Counter    |                  |        |
|                 |                |                             | 6 DCLink Voltage   |                  |        |
|                 |                |                             | 7 DI State         |                  |        |
|                 |                |                             | 8 DO State         |                  |        |
|                 |                |                             | 9 V1 Monitor (V)   |                  |        |
|                 |                |                             | 10 V1 Monitor (%)  |                  |        |
|                 |                |                             | 11 I1 Monitor (mA) |                  |        |
|                 |                |                             | 12 I1 Monitor (%)  |                  |        |
|                 |                |                             | 13 V2 Monitor (V)  |                  |        |
|                 |                |                             | 14 V2 Monitor (%)  |                  |        |
|                 |                |                             | 15 I2 Monitor (mA) |                  |        |
|                 |                |                             | 16 I2 Monitor (%)  |                  |        |
|                 |                |                             | 17 PID Output      |                  |        |
|                 |                |                             | 18 PID ref Value   |                  |        |
|                 |                |                             | 19 PID Fdb Value   |                  |        |
| 20 Torque       |                |                             |                    |                  |        |
| 21 Torque Limit |                |                             |                    |                  |        |
| 22 Trq Bias Ref |                |                             |                    |                  |        |
| 23 Speed Limit  |                |                             |                    |                  |        |
| 24 Load Speed   |                |                             |                    |                  |        |
| 25 Temperature  |                |                             |                    |                  |        |
| 24              | Mon Mode Init  | Monitor mode initialization | 0 No               | 0:No             | 284    |
|                 |                |                             | 1 Yes              |                  |        |
| 30              | Option-1 Type  | Option slot 1 type display  | 0 None             | 0:None           | Option |
| 31              | Option-2 Type  | Option slot 2 type display  | 1 PLC              | 0:None           | Option |
| 32              | Option-3 Type  | Option slot 3 type display  | 2 Profi            | 0:None           | Option |
|                 |                |                             | 3 Ext. I/O         |                  |        |
|                 |                |                             | 4 Encoder          |                  |        |
| 40              | Parameter Init | Parameter initialization    | 0 No               | -                | 257    |
|                 |                |                             | 1 All Grp          |                  |        |
|                 |                |                             | 2 DRV Grp          |                  |        |
|                 |                |                             | 3 BAS Grp          |                  |        |
|                 |                |                             | 4 ADV Grp          |                  |        |
|                 |                |                             | 5 CON Grp          |                  |        |
|                 |                |                             | 6 IN Grp           |                  |        |
|                 |                |                             | 7 OUT Grp          |                  |        |
| 8 COM Grp       |                |                             |                    |                  |        |

## Table of Functions

| No. | LCD Display     | Name  | Setting Range        | Initial Value | Page |
|-----|-----------------|---|----------------------|---------------|------|
|     |                 |   | 9 APP Grp            |               |      |
|     |                 |   | 10 AUT Grp           |               |      |
|     |                 |   | 11 APO Grp           |               |      |
|     |                 |   | 12 PRT Grp           |               |      |
|     |                 |   | 13 M2 Grp            |               |      |
| 41  | Changed Para    | Display changed parameter                             | 0 View All           | 0:View All    | 260  |
|     |                 |   | 1 View Changed       |               |      |
| 42  | Multi Key Sel   | Multi-function key item                               | 0 None               | 0:None        | 260  |
|     |                 |   | 1 JOG Key            |               |      |
|     |                 |   | 2 Local/Remote       |               |      |
|     |                 |   | 3 UserGrp SelKey     |               |      |
| 43  | Macro Select    | Macro function item                                   | 0 None               | 0:None        | 262  |
|     |                 |   | 1 Draw App           |               |      |
|     |                 |   | 2 Traverse           |               |      |
| 44  | Erase All Trip  | Delete trip history                                   | 0 No                 | 0:No          | 264  |
|     |                 |   | 1 Yes                |               |      |
| 45  | UserGrp AllDel  | Delete user registration code                         | 0 No                 | 0:No          | 260  |
|     |                 |   | 1 Yes                |               |      |
| 46  | Parameter Read  | Read parameters                                       | 0 No                 | 0:No          | 256  |
|     |                 |   | 1 Yes                |               |      |
| 47  | Parameter Write | Write parameters                                      | 0 No                 | 0:No          | 256  |
|     |                 |   | 1 Yes                |               |      |
| 48  | Parameter Save  | Save parameters                                       | 0 No                 | 0:No          | 256  |
|     |                 |   | 1 Yes                |               |      |
| 50  | View Lock Set   | Hide parameter mode                                   | 0-9999               | Unlocked      | 258  |
| 51  | View Lock Pw    | Password for hiding parameter mode                    | 0-9999               | Password      | 258  |
| 52  | Key Lock Set    | Lock parameter edit                                   | 0-9999               | Unlocked      | 259  |
| 53  | Key Lock Pw     | Password for locking parameter edit                   | 0-9999               | Password      | 259  |
| 60  | Add Title Del   | Additional title update                               | 0 No                 | 0:No          | 264  |
|     |                 |   | 1 Yes                |               |      |
| 61  | Easy Start On   | Simple parameter setting                              | 0 No                 | 0:No          | 263  |
|     |                 |   | 1 Yes                |               |      |
| 62  | WHCount Reset   | Power consumption initialization                      | 0 No                 | 0:No          | 264  |
|     |                 |   | 1 Yes                |               |      |
| 70  | On-time         | Accumulated inverter motion time                      | 0000DAY<br>00hr:00mm | -             | 264  |
| 71  | Run-time        | Accumulated inverter operation time                   | 0000DAY<br>00hr:00mm | -             | 264  |
| 72  | Time Reset      | Accumulated inverter operation time initialization    | 0 No                 | 0:No          | 264  |
|     |                 |   | 1 Yes                |               |      |
| 74  | Fan Time        | Accumulated cooling fan operation time                | 0000DAY<br>00hr:00mm | -             | 264  |
| 75  | Fan Time Rst    | Accumulated cooling fan operation time initialization | 0 No                 | -             | 264  |
|     |                 |   | 1 Yes                |               |      |

Note 43) Item 7 and 8 are not in the Anytime Para item.

## 13.14 User/Macro Mode – Draw Operation Function Group → MC1

### U&M → MC1

| No. | LCD Display    | Name                               | Setting Range | Initial Value | Page |     |
|-----|----------------|------------------------------------|---------------|---------------|------|-----|
| 00  | Jump Code      | Jump code                          | 0-99          | 1             | -    |     |
| 01  | Acc Time       | Acceleration time                  | 0-600 (sec)   | Below 75 kW   | 20   | 171 |
|     |                |                                    |               | Above 90 kW   | 60   |     |
| 02  | Dec Time       | Deceleration time                  | 0-600 (sec)   | Below 75 kW   | 30   | 171 |
|     |                |                                    |               | Above 90 kW   | 90   |     |
| 03  | Cmd Source     | Command source                     | 0-5           | 1:Fx/Rx-1     | 159  |     |
| 04  | Freq Ref Src   | Frequency reference source         | 0-9           | 2:V1          | 137  |     |
| 05  | Control Mode   | Control mode                       | 0-5           | 0:V/F         | 174  |     |
| 06  | Aux Ref Src    | Auxiliary reference source         | 0-4           | 2:11          | 194  |     |
| 07  | Aux Calc Type  | Auxiliary calculation type         | 0-7           | 0             | 194  |     |
| 08  | Aux Ref Gain   | Auxiliary reference gain           | -200-200 (%)  | 100.0         | 194  |     |
| 09  | V1 Polarity    | V1 input polarity selection        | 0-1           | 0:Unipolar    | 138  |     |
| 10  | V1 Filter      | V1 input filter time constant      | 0-10000 (ms)  | 10            | 138  |     |
| 11  | V1 Volt x1     | V1 minimum input voltage           | 0-10 (V)      | 0.00          | 138  |     |
| 12  | V1 Perc y1     | Output at V1 minimum voltage (%)   | 0-100 (%)     | 0.00          | 138  |     |
| 13  | V1 Volt x2     | V1 maximum input voltage           | 0-10 (V)      | 10.00         | 138  |     |
| 14  | V1 Perc y2     | Output at V1 maximum voltage (%)   | 0-100 (%)     | 100.00        | 138  |     |
| 15  | V1 -Volt x1'   | V1 -minimum input voltage          | -10-0 (V)     | 0.00          | 138  |     |
| 16  | V1 -Perc y1'   | Output at V1 -minimum voltage (%)  | -100-0 (%)    | 0.00          | 138  |     |
| 17  | V1 -Volt x2'   | V1 -maximum input voltage          | -10-0 (V)     | -10.00        | 138  |     |
| 18  | V1 -Perc y2'   | Output at V1 -maximum voltage (%)  | -100-0 (%)    | -100.00       | 138  |     |
| 19  | V1 Inverting   | Rotation direction change          | 0-1           | 0:No          | 138  |     |
| 20  | I1 Monitor(mA) | I1 input amount display            | 0-20 (mA)     | 0.00          | 146  |     |
| 21  | I1 Polarity    | I1 polarity display                | 0-1           | 0             | 146  |     |
| 22  | I1 Filter      | I1 input filter time constant      | 0-10000 (ms)  | 10            | 146  |     |
| 23  | I1 Curr x1     | I1 minimum input current           | 0-20 (mA)     | 4.00          | 146  |     |
| 24  | I1 Perc y1     | Output at I1 minimum current (%)   | 0-100 (%)     | 0.00          | 146  |     |
| 25  | I1 Curr x2     | I1 maximum input current           | 4-20 (mA)     | 20.00         | 146  |     |
| 26  | I1 Perc y2     | Output at I1 maximum current (%)   | 0-100 (%)     | 100.00        | 146  |     |
| 27  | I1 Curr x1'    | I1 -minimum input current          | -20-0 (mA)    | 0.00          | 146  |     |
| 28  | I1 Perc y1'    | Output at I1 - minimum current (%) | -100-0 (%)    | 0.00          | 146  |     |
| 29  | I1 Curr x2'    | I1 - maximum input current         | -20-0 (mA)    | -20.00        | 146  |     |
| 30  | I1 Perc y2'    | Output at I1 maximum current (%)   | -100-0 (%)    | -100.00       | 146  |     |
| 31  | I1 Inverting   | Rotation direction change          | 0-1           | 0:No          | 146  |     |
| 32  | P1 Define      | P1 terminal function setting       | 0-48          | 0:FX          | 159  |     |
| 33  | P2 Define      | P2 terminal function setting       | 0-48          | 1:RX          | 159  |     |
| 34  | P3 Define      | P3 terminal function setting       | 0-48          | 5:BX          | 328  |     |



## 13.15 User/Macro mode – Traverse Operation Function Group (→MC2)

### Traverse Operation Function Group (U&M → MC2)

| No. | LCD Display   | Name                         | Setting Range | Initial Value | Page |     |
|-----|---------------|------------------------------|---------------|---------------|------|-----|
| 00  | Jump Code     | Jump code                    | 0-99          | 1             | -    |     |
| 01  | Acc Time      | Acceleration time            | 0-600 (sec)   | Below 75 kW   | 20   | 266 |
|     |               |                              |               | Above 90 kW   | 60   |     |
| 02  | Dec Time      | Deceleration time            | 0-600 (sec)   | Below 75 kW   | 30   | 266 |
|     |               |                              |               | Above 90 kW   | 90   |     |
| 03  | Cmd Source    | Command source               | 0-5           | 1:Fx/Rx-1     | 266  |     |
| 04  | Freq Ref Src  | Frequency reference source   | 0-9           | 0:Keypad-1    | 266  |     |
| 05  | Control Mode  | Control mode                 | 0-5           | 0:V/F         | 266  |     |
| 06  | App Mode      | Applied function selection   | 0-4           | 1:Traverse    | 266  |     |
| 07  | Trv Apmlit %  | Traverse operating range     | 0-20 (%)      | 0.0           | 266  |     |
| 08  | Trv Scramb %  | Traverse scramble magnitude  | 0-50 (%)      | 0.0           | 266  |     |
| 09  | Trv Acc Time  | Traverse acceleration time   | 0.1-600 (sec) | 2.0           | 266  |     |
| 10  | Trv Dec Time  | Traverse deceleration time   | 0.1-600 (sec) | 2.0           | 266  |     |
| 11  | Trv Offset Hi | Traverse offset upper limit  | 0-20 (%)      | 0.0           | 266  |     |
| 12  | Trv Offset lo | Traverse offset lower limit  | 0-20 (%)      | 0.0           | 266  |     |
| 13  | P1 Define     | P1 terminal function setting | 0-48          | 0:FX          | 266  |     |
| 14  | P2 Define     | P2 terminal function setting | 0-48          | 1:RX          | 266  |     |
| 15  | P3 Define     | P3 terminal function setting | 0-48          | 5:BX          | 266  |     |
| 16  | P4 Define     | P4 terminal function setting | 0-48          | 27:Trv        | 266  |     |
| 17  | P5 Define     | P5 terminal function setting | 0-48          | 28:Trv        | 266  |     |

## 14 Safety Function STO(Safe Torque Off)

The iS7 Inverter series provides resilient safety features via optional safety expansion module. When an emergency arises, it instantly blocks inverter output to protect the operator and reduce the risk.

### 14.1 Safety Standard Product

The performance levels for the safety function are as follows.

**EN ISO 13849-1: Category 3, PL Class d**

**EN 61508: SIL 2 (EN 60204-1, Stop Category 0)**

#### ⚠ Caution

When using the safety function, perform a risk assessment for the system and ensure that it meets the safety requirements.

#### Note

When wiring the inverter or performing maintenance, the inverter must be turned off. The safety function is not used to block the power supply to the motor or insulate the inverter electrically.

### 14.2 About the Safety Function

The safety function is a safety torque off (STO) function used to prevent a torque and to block the power supply to the motor by interrupting the gate using hard wires.

#### **STO (Safety Torque Off): IEC61800-5-2**

The STO function is independently connected to each input signal for 2 channels (SE(SFT11) and SP(SFT2)). The connected circuit cuts off the operation signal for the inverter output and turns off the power modules.

If the safety function is activated during operation, the inverter blocks the output and the motor enters Free Run mode. Also, the "Safety Opt Err" message is displayed on the keypad.

To release the fault trip, short-circuit terminal block to return to the normal operation status and press the [STOP/RESET] key.

### 14.2.1 Safety Function Wiring Diagram

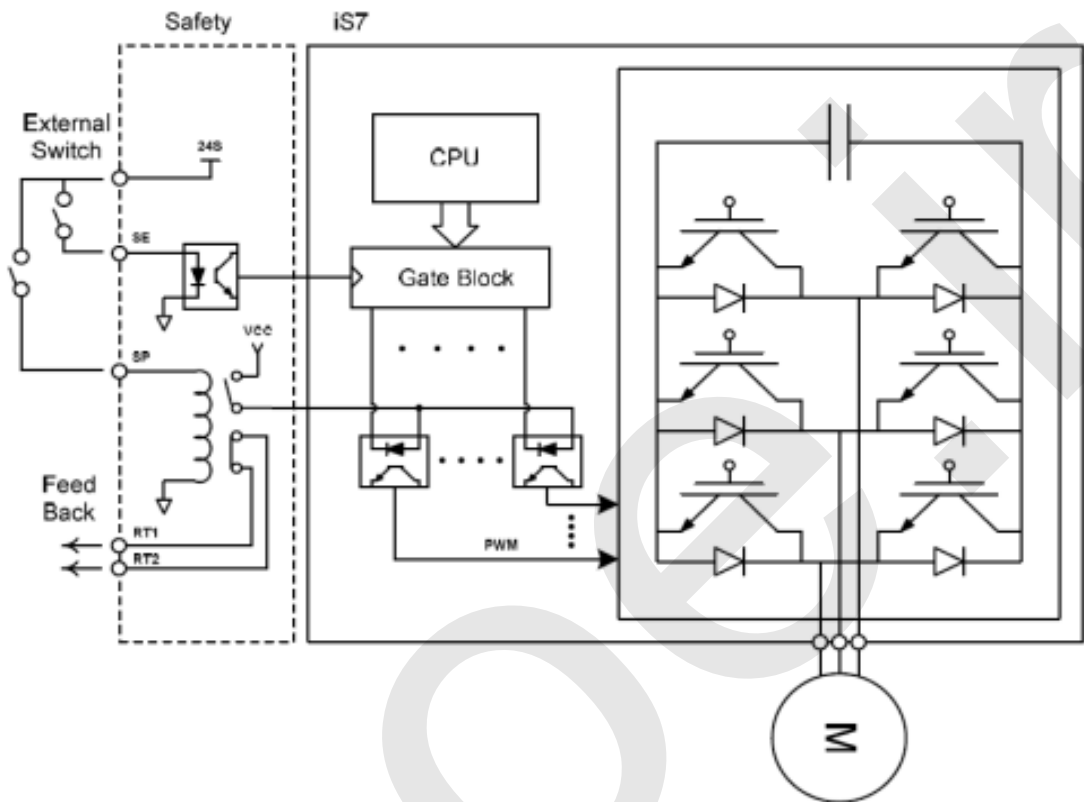

### 14.2.2 Installing the Safety Board to 0.75–160 kW Product

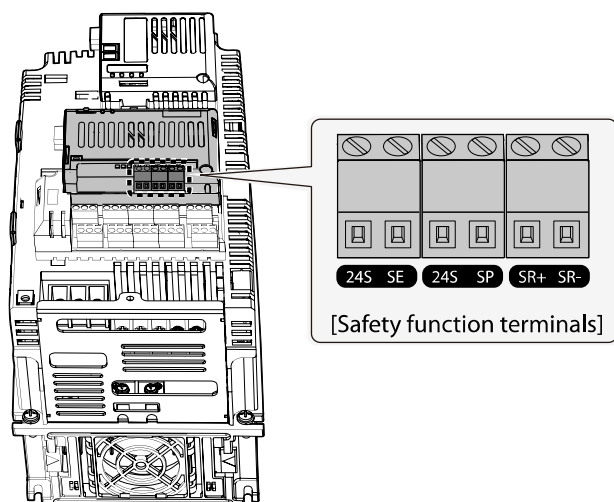

#### ⚠ Caution

Because 0.75-160kW products provide safety purpose product, therefore please use this product with safety option.  
 Safety options are not available for general products.

### 14.2.3 Installing the Safety Board to 185–375 kW Product

Please buy safety option and apply to standard products because there is no safety product for 185-375kW.

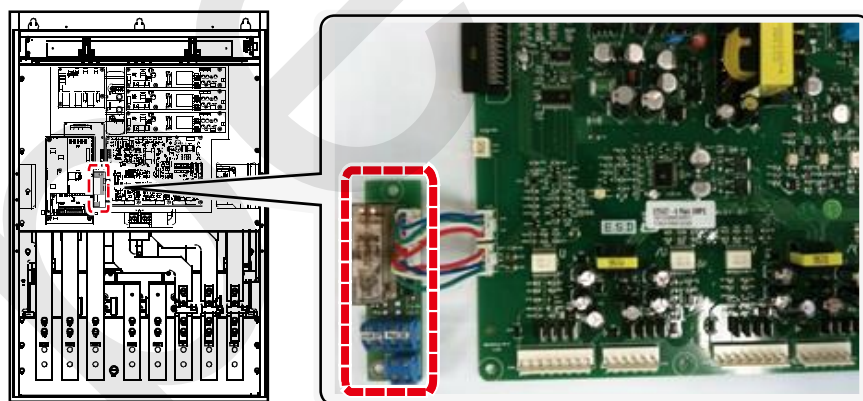

Refer to the following figure and install the safety board to the main SMPS board of the inverter using cable connectors.

### 14.2.4 Safety Function Terminal Description

| 24S – SE (SFT1)                      | 24S – SP (SFT2)                     | SR + SR-                        |
|--------------------------------------|-------------------------------------|---------------------------------|
| Short: Normal operation              | Short: Normal operation             | B Contact relay output terminal |
| Open: Safety Trip (output blockage ) | Open: Safety Trip (output blockage) |                                 |

### 14.2.5 Cable Specification for Signal Terminal Block Wiring

| Terminal |  | Wire Thickness  |     | Electrical Standard   |
|----------|--|---|-----|---|
| Variety  | Name                                       | mm <sup>2</sup>   | AWG |   |
| 24S      | Safety Input power                         | 0.33–1.25mm <sup>2</sup><br>(16–22 AWG)<br>Shield type<br>twisted-pair wire |     | 24 VDC, Max. 10 mA  |
| SE       | Safety Input 1 (SFT1)                      |   |     | Short: Safety function stop<br>(24S-SE or SP)<br>Open: Safety function operation (24S-<br>SP or SP) |
| SP       | Safety Input 2 (SFT2)                      |   |     |   |
| SR+,SR-  | Safety function completion<br>output relay |   |     | DC 24 V, 5 A below (B contact)  |

#### ⚠ Caution

The length of the safety wiring at the input terminal must be less than 30 m. Longer wiring can Using over 30M may cause malfunctions because of noise.

## 15 Marine Certification

Marine classification is that the structure and equipment of the ship has been estimated from the test with the certain standards for certificate issued and given by classification society.

SV-IS7 Series is certificated with product testing, process, production equipment and test equipment to install on the shipping.

### 15.1 DNV (Det Norske Veritas) Marine Certification Details

|                         |   |
|-------------------------|---|
| Certification Institute | DNV (Det Norske Veritas)  |
| Certificate Number      | TAE00001S1  |
| Certified Model Types   | Frequency Converter for Asynchronous Motors SV series<br>(Range: 0.75 kW–375 kW 200–400 VAC supply)                       |
| Compliance              | Det Norske Veritas' Rules for Classification of Ships, High Speed & Light Craft<br>Det Norske Veritas' Offshore Standards |

### 15.2 Bureau Veritas (Marine & Offshore Division) Marine Certification Details

|                         |   |
|-------------------------|---|
| Certification Institute | Bureau Veritas (Marine&Off shore Division)                        |
| Certificate Number      | 40183/AO BV   |
| Certified Model Types   | SV-IS7 series (Range: 0.75 kW–75 kW, 200V / 0.75 kW–375 kW, 400V) |
| Compliance              | Bureau Veritas Rules for the Classification of Steel Ships        |

### 15.3 ABS Marine Certification Details

|                         |  |
|-------------------------|--|
| Certification institute | ABS (American Bureau of Shipping)                                    |
| Certificate Number      | 14-BK1291913-PDA   |
| Certified Model Types   | SV-IS7 series (Range: 0.75 kW–75 kW, 200V / 0.75 kW–90 kW, 400V)     |
| Compliance              | Installation of the product on an ABS class vessel, MODU or facility |

### 15.4 KR Marine Certification Details

|                         |                      |
|-------------------------|----------------------|
| Certification institute | KR (Korean Resister) |
|-------------------------|----------------------|

|                       |   |
|-----------------------|---|
| Certificate Number    | PTD25585-AC003  |
| Certified Model Types | SV-iS7 series (Range: 0.75 kW–75 kW, 200V / 0.75 kW–375 kW, 400V) |
| Compliance            | Korean Resister's Rules for Classification of Steel Ships         |

## 15.5 Marine Certification Models for SV-iS7 Products

| Type            |                  | DNV | BV | ABS | KR |
|-----------------|------------------|-----|----|-----|----|
| 3-Phase<br>200V | SV0008iS7-2□□□□V | ○   | ○  | ○   | ○  |
|                 | SV0015iS7-2□□□□V | ○   | ○  | ○   | ○  |
|                 | SV0022iS7-2□□□□V | ○   | ○  | ○   | ○  |
|                 | SV0037iS7-2□□□□V | ○   | ○  | ○   | ○  |
|                 | SV0055iS7-2□□□□V | ○   | ○  | ○   | ○  |
|                 | SV0075iS7-2□□□□V | ○   | ○  | ○   | ○  |
|                 | SV0110iS7-2□□□□V | ○   | ○  | ○   | ○  |
|                 | SV0150iS7-2□□□□V | ○   | ○  | ○   | ○  |
|                 | SV0185iS7-2□□□□V | ○   | ○  | ○   | ○  |
|                 | SV0220iS7-2□□□□V | ○   | ○  | ○   | ○  |
|                 | SV0300iS7-2□□□□V | ○   | ○  | ○   | ○  |
|                 | SV0370iS7-2□□□□V | ○   | ○  | ○   | ○  |
|                 | SV0450iS7-2□□□□V | ○   | ○  | ○   | ○  |
|                 | SV0550iS7-2□□□□V | ○   | ○  | ○   | ○  |
|                 | SV0750iS7-2□□□□V | ○   | ○  | ○   | ○  |
| 3-Phase<br>400V | SV0008iS7-4□□□□V | ○   | ○  | ○   | ○  |
|                 | SV0015iS7-4□□□□V | ○   | ○  | ○   | ○  |
|                 | SV0022iS7-4□□□□V | ○   | ○  | ○   | ○  |
|                 | SV0037iS7-4□□□□V | ○   | ○  | ○   | ○  |
|                 | SV0055iS7-4□□□□V | ○   | ○  | ○   | ○  |
|                 | SV0075iS7-4□□□□V | ○   | ○  | ○   | ○  |
|                 | SV0110iS7-4□□□□V | ○   | ○  | ○   | ○  |
|                 | SV0150iS7-4□□□□V | ○   | ○  | ○   | ○  |
|                 | SV0185iS7-4□□□□V | ○   | ○  | ○   | ○  |

| Type             | DNV | BV | ABS | KR |
|------------------|-----|----|-----|----|
| SV0220iS7-4□□□□V | O   | O  | O   | O  |
| SV0300iS7-4□□□□V | O   | O  | O   | O  |
| SV0370iS7-4□□□□V | O   | O  | O   | O  |
| SV0450iS7-4□□□□V | O   | O  | O   | O  |
| SV0550iS7-4□□□□V | O   | O  | O   | O  |
| SV0750iS7-4□□□□V | O   | O  | O   | O  |
| SV0900iS7-4□□□□V | O   | O  | O   | O  |
| SV1100iS7-4□□□□V | O   | O  | X   | O  |
| SV1320iS7-4□□□□V | O   | O  | X   | O  |
| SV1600iS7-4□□□□V | O   | O  | X   | O  |
| SV1850iS7-4□□□□V | O   | O  | X   | O  |
| SV2200iS7-4□□□□V | O   | O  | X   | O  |
| SV2800iS7-4□□□□V | O   | O  | X   | O  |
| SV3150iS7-4□□□□V | O   | O  | X   | O  |
| SV3750iS7-4□□□□V | O   | O  | X   | O  |

Classified Product



# 16 Using a Single Phase Power Source

## 16.1 Single Phase Rating

The SV-iS7 series inverter is a three-phase variable frequency drive (VFD). When applying single-phase power to a three-phase VFD, there are several limitations that need to be considered.

The standard pulse-width-modulated (PWM) VFDs use a 6-pulse diode rectifier. The 6-pulse rectification results in 360 Hz (or 300 Hz) DC bus ripple when using a three-phase 60 Hz (or 50 Hz) power supply. However, when using a single-phase power source, the DC bus ripple becomes 120 Hz (or 100 Hz). The input current and harmonics increase, and the VFDs DC bus circuit is subject to higher stress in order to deliver equivalent power.

Input current distortion of 90% THD and greater can be expected under single-phase input, compared to approximately 40% with three-phase input as indicated in Figure 2.

Therefore, use of a single-phase requires the three-phase VFD power rating to be reduced (derated) to avoid over stressing the rectifier and the DC link components.

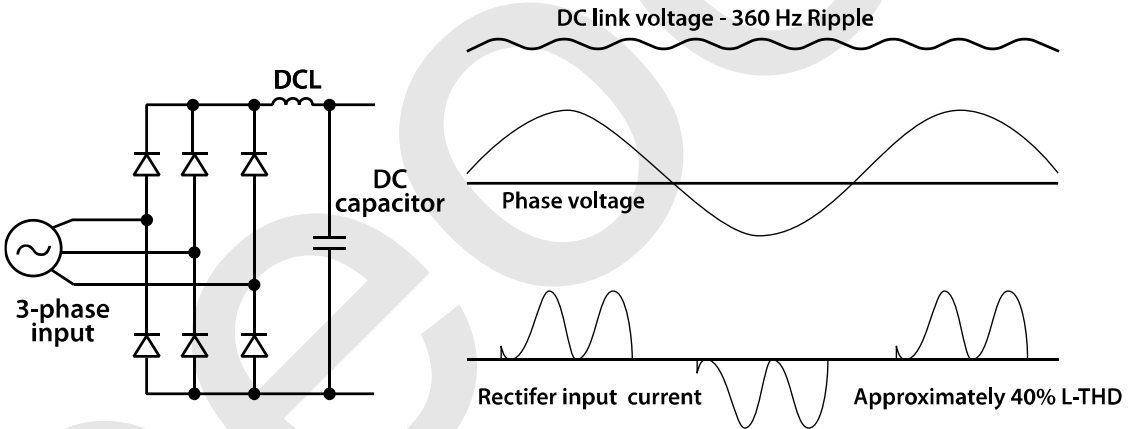

<Figure-1 Typical 60 Hz Three-Phase Configuration>

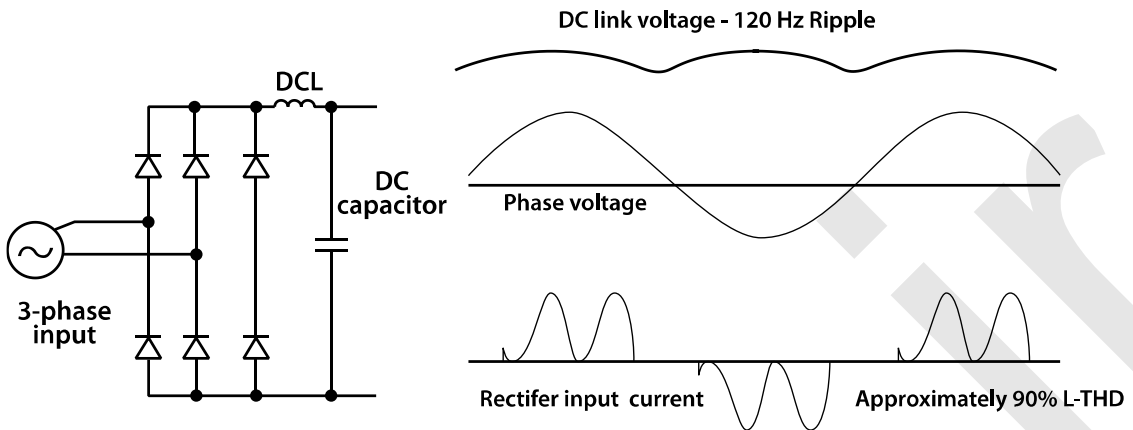

<Figure-2 Typical 60 Hz Single-Phase Configuration>

## 16.2 Power(HP), Input Current and Output Current

When using a three-phase VFD with single-phase input, derating the drive's output current and horsepower will be necessary due to the increase in DC bus ripple voltage and current. In addition, the input current through the remaining two phases on the diode bridge converter will approximately double, creating another derating consideration for the VFD. Input current harmonic distortion will increase, making the overall input power factor low.

Input current distortion over 100% is likely under single-phase conditions without a reactor. Therefore, the reactor is always required for such applications.

Using a motor that is selected by the three-phase drive ratings with single-phase input may result in poor performance and premature drive failure.

The selected drive of single-phase current ratings must meet or exceed the motor current ratings as indicated in the following table.

## 16.3 Input Frequency and Voltage Tolerance

The AC supply voltage must be within the required voltage range of 240/480 VAC +10% to -5% to maximize motor power production.

The standard product with three-phase voltage input has an allowable range of +10% to -15%. A stricter input voltage tolerance of +10 to -5% applies when using the drive with a single-phase supply. The average bus voltage with single-phase input is lower than the equivalent of a three-phase input. Therefore, the maximum output voltage (motor voltage) will be lower with a single-phase input.

The minimum input voltage must be no less than 228 VAC for 240 volt models and 456 VAC for 480 V models, to ensure motor voltage production of 207 VAC and 415 VAC, respectively.

If full motor torque must be developed near the base speed (full power) it will be necessary to maintain a rigid incoming line voltage so that adequate motor voltage can be produced.

Operating a motor at reduced speed (reduced power), or using a motor with a base voltage that is lower than the incoming AC supply rating (ex. 208 VAC motor with a 240 VAC supply) will also minimize the effect of voltage deprivation ( 240 VAC Input for 208 V motor, 480 VAC Input for 400 V motor).

## 16.4 Wiring and Peripheral Device

It is important that input wiring and branch circuit protection be selected based on the drive's single-phase input current rating indicated in Table 1-2.

The single-phase input current after derating differs from the three-phase input indicated on the VFD nameplate.

Refer to the following figure and connect the single-phase AC input wiring to the inverter's R[L1] and T[L3] terminals.

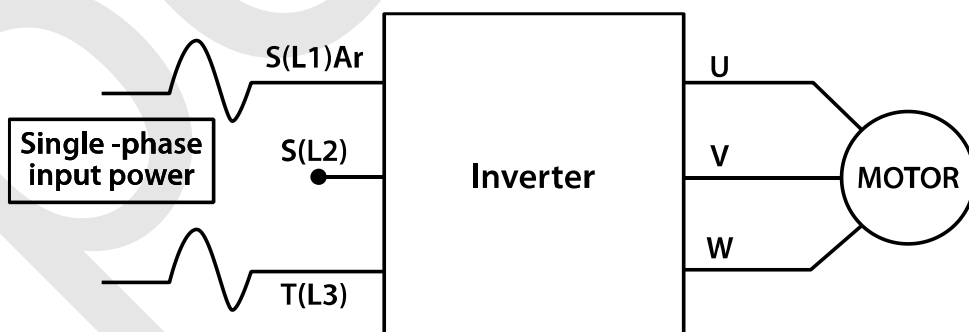

<Figure-3 Terminal Wiring Diagram>

| Single-Phase Rating (240 V / 50~60 Hz Input) |      |                             |        |           |        |                |       |      |      |               |             |                      |                      |         |
|--|------|-----------------------------|--------|-----------|--------|----------------|-------|------|------|---------------|-------------|----------------------|----------------------|---------|
| [kW]   | [HP] | Single-Phase Current Rating |        |           |        | Wire Selection |       | FUSE |      | DC Link Choke |             | MCCB                 | Electronic Contactor |         |
|  |      | Output Amp                  |        | Input Amp |        | AWG            |       | [A]  | [V]  | [mH]          | [A]         | LS ELECTRIC(UL Type) |                      |         |
|  |      | HD [A]                      | ND [A] | HD [A]    | ND [A] | R,S,T          | U,V,W |      |      |               |             |                      |                      |         |
| 0.75kW                                       | 1    | 2.6                         | 4.1    | 4.3       | 6.8    | 14             | 14    | 10   | 500V | Built-in      | UTE100/15A  | MC-9b                |                      |         |
| 1.5kW  | 2    | 4.0                         | 6.0    | 6.9       | 10.6   | 14             | 14    | 15   |      |               | UTE100/15A  | MC-12b               |                      |         |
| 2.2kW  | 3    | 6.2                         | 8.2    | 11.2      | 14.9   | 14             | 14    | 20   |      |               | UTE100/30A  | MC-18b               |                      |         |
| 3.7kW  | 5    | 8.1                         | 12     | 14.9      | 21.3   | 12             | 12    | 32   |      |               | UTE100/30A  | MC-32a               |                      |         |
| 5.5kW  | 7.5  | 12                          | 16     | 22.1      | 28.6   | 10             | 10    | 50   |      |               | UTS150/50A  | MC-40a               |                      |         |
| 7.5kW  | 10   | 16                          | 23     | 28.6      | 41.2   | 8              | 8     | 63   |      |               | UTS150/60A  | MC-50a               |                      |         |
| 11kW   | 15   | 24                          | 31     | 44.3      | 54.7   | 6              | 6     | 80   |      |               | UTS150/100A | MC-65a               |                      |         |
| 15kW   | 20   | 31                          | 38     | 55.9      | 69.7   | 4              | 4     | 100  |      |               | UTS150/125A | MC-100a              |                      |         |
| 18.5kW                                       | 25   | 38                          | 45     | 70.8      | 82.9   | 2              | 2     | 125  |      |               | UTS150/150A | MC-130a              |                      |         |
| 22kW   | 30   | 45                          | 64     | 85.3      | 116.1  | 1              | 1     | 160  |      |               | UTS250/175A | MC-150a              |                      |         |
| 30kW   | 40   | 60                          | 75     | 121.0     | 152.0  | 1/0            | 1/0   | 200  |      |               | 0.24        | 200                  | UTS250/225A          | MC-150a |
| 37kW   | 50   | 75                          | 93     | 154.0     | 190.0  | 2/0            | 2/0   | 250  |      |               | 0.2         | 240                  | UTS400/300A          | MC-225a |
| 45kW   | 60   | 93                          | 114    | 191.0     | 231.0  | 2/0            | 2/0   | 350  |      |               | 0.17        | 280                  | UTS400/350A          | MC-330a |
| 55kW   | 75   | 114                         | 149    | 233.0     | 302.0  | 3/0            | 3/0   | 400  |      |               | 0.12        | 360                  | UTS600/500A          | MC-400a |
| 75kW   | 100  | 149                         | 178    | 305.0     | 362.0  | 4/0            | 4/0   | 450  | 0.1  | 500           | UTS600/600A | MC-630a              |                      |         |

Table 1. Single-Phase Rating(240 V Type)

## Using a Single Phase Power Source

| Single-Phase Rating (480 V / 50~60 Hz Input) |      |                             |        |           |        |                |       |      |      |               |             |                      |                      |
|--|------|-----------------------------|--------|-----------|--------|----------------|-------|------|------|---------------|-------------|----------------------|----------------------|
| [kW]   | [HP] | Single-Phase Current Rating |        |           |        | Wire Selection |       | FUSE |      | DC Link Choke |             | MCCB                 | Electronic Contactor |
|  |      | Output Amp                  |        | Input Amp |        | AWG            |       |      |      |               |             |                      |                      |
|  |      | HD [A]                      | ND [A] | HD [A]    | ND [A] | R,S,T          | U,V,W | [A]  | [V]  | [mH]          | [A]         | LS ELECTRIC(UL Type) |                      |
| 0.75kW                                       | 1    | 1.4                         | 2.2    | 2.2       | 3.7    | 14             | 14    | 10   | 500V | Built-in      | UTE100/15A  | MC-9b                |                      |
| 1.5kW  | 2    | 2.1                         | 3.2    | 3.6       | 5.7    | 14             | 14    | 10   |      |               | UTE100/15A  | MC-9b                |                      |
| 2.2kW  | 3    | 2.8                         | 4.1    | 5.5       | 7.7    | 14             | 14    | 15   |      |               | UTE100/15A  | MC-12b               |                      |
| 3.7kW  | 5    | 4.1                         | 6.1    | 7.5       | 11.1   | 14             | 14    | 20   |      |               | UTE100/15A  | MC-18b               |                      |
| 5.5kW  | 7.5  | 6.1                         | 8.0    | 11.0      | 14.7   | 12             | 12    | 32   |      |               | UTE100/30A  | MC-22b               |                      |
| 7.5kW  | 10   | 8.1                         | 12     | 14.4      | 21.9   | 12             | 12    | 35   |      |               | UTE100/30A  | MC-32a               |                      |
| 11kW   | 15   | 12                          | 16     | 22.0      | 26.4   | 10             | 10    | 50   |      |               | UTS150/50A  | MC-40a               |                      |
| 15kW   | 20   | 16                          | 20     | 26.6      | 35.5   | 8              | 8     | 63   |      |               | UTS150/60A  | MC-50a               |                      |
| 18.5kW                                       | 25   | 20                          | 23     | 35.6      | 41.1   | 6              | 6     | 70   |      |               | UTS150/80A  | MC-65a               |                      |
| 22kW   | 30   | 23                          | 31     | 41.6      | 55.7   | 4              | 4     | 100  |      |               | UTS150/100A | MC-65a               |                      |
| 30kW   | 40   | 32                          | 39     | 55.5      | 67.5   | 4              | 4     | 125  |      |               | UTS150/125A | MC-100a              |                      |
| 37kW   | 50   | 39                          | 47     | 67.9      | 81.7   | 4              | 2     | 125  |      |               | UTS150/150A | MC-130a              |                      |
| 45kW   | 60   | 47                          | 57     | 82.4      | 101.8  | 1              | 1     | 160  |      |               | UTS250/175A | MC-150a              |                      |
| 55kW   | 75   | 57                          | 78     | 102.6     | 143.6  | 1/0            | 1/0   | 200  |      |               | UTS250/225A | MC-185a              |                      |
| 75kW   | 100  | 78                          | 94     | 143.4     | 173.4  | 2/0            | 2/0   | 250  |      |               | UTS400/300A | MC-225a              |                      |
| 90kW   | 120  | 95                          | 116    | 174.7     | 212.9  | 4/0            | 4/0   | 350  |      |               | UTS400/400A | MC-330a              |                      |
| 110kW  | 150  | 116                         | 138    | 213.5     | 254.2  | 4/0            | 4/0   | 400  |      |               | UTS600/500A | MC-400a              |                      |
| 132kW  | 180  | 134                         | 165    | 255.6     | 315.3  | 300            | 300   | 450  |      |               | UTS600/600A | MC-400a              |                      |
| 160kW  | 225  | 166                         | 189    | 316.3     | 359.3  | 400            | 400   | 450  |      |               | UTS600/600A | MC-630a              |                      |

Table 2. Single-Phase Rating (480 V Type)

## 16.5 Other Considerations

The following lists other precautions that need to be considered when using a three-phase VFD using single-phase power source.

- Depending on the increased DC ripple, sensorless mode may result in poor performance when operating a three-phase inverter using single-phase power supply.
- If a phase open trip occurs, cancel the input phase open protection bit setting (PRT-05: Phase Loss Chk).
- Do not allow the current to exceed the single-phase rating. Motor capacity, motor overload trip, and E-thermal functions must be set to protect motor.
- A reactor is always required. Use a model type that comes with built-in DC reactor. The iS7 200 V 30–75kW and 400 V 280–375 kW products do not have built-in DC reactors. Install an external AC reactor separately for these model types (Do not install DC reactors externally).

# 17 Storage and Disposal

## 17.1 Storage

If you are not using the product for an extended period, store it in the following way:

- Store the product in the same environmental conditions as specified for operation (refer to [3.1 Installation Considerations](#) on page 17).
- When storing the product for a period longer than 3 months, store it between 0°C and 65°C, to prevent depletion of the electrolytic capacitor.
- Do not expose the drive to snow, rain, fog, or dust.
- Package the inverter in a way that prevents contact with moisture. Keep the moisture level below 70% in the package by including a desiccant, such as silica gel.
- If the product is exposed to a humid or dusty environment, separate the product and then keep it in an adequate environment that is suitable for product operation.

### ⚠ Caution

If the inverter has not been operated for a long time, capacitors may lose their charging characteristics and become depleted. To prevent depletion, turn on the product once a year and allow the device to operate for 30-60 min. Run the device under no-load conditions.

## 17.2 Disposal

When disposing of the product, categorize it as general industrial waste. Recyclable materials are included in the product, so recycle them whenever possible. The packing materials and all metal parts can be recycled.



## EC DECLARATION OF CONFORMITY

We, the undersigned,

Representative: **LS ELECTRIC Co., Ltd.**  
 Address: **LS Tower, 127, LS-ro, Dongan-gu,  
 Anyang-si, Gyeonggi-do,  
 Korea**

Manufacturer: **LS ELECTRIC Co., Ltd.**  
 Address: **56, Samseong 4-gil, Mokcheon-eup,  
 Dongnam-gu, Cheonan-si, Chungcheongnam-do,  
 Korea**

**Certify and declare under our sole responsibility that the following apparatus:**

Type of Equipment: **Inverter (Power Conversion Equipment)**  
 Model Name: **STARVERT-/S7 series**  
 Trade Mark: **LS ELECTRIC Co., Ltd.**

**Conforms with the essential requirements of the directives:**

2014/35/EU Directive of the European Parliament and of the Council on the harmonisation of the laws of the Member States relating to the making available on the market of electrical equipment designed for use within certain voltage limits.

2014/30/EU Directive of the European Parliament and of the Council on the harmonisation of the laws of the Member States relating to electromagnetic compatibility.

**Based on the following specifications applied:**

**EN IEC 61800-3:2018  
 EN 61800-5-1:2007+A1:2017+A11:2021  
 EN IEC 63000:2018**

**and therefore complies with the essential requirements and provisions of the 2014/30/EU, 2014/35/EU and 2011/65/EU Directives.**

Place: **Cheonan, Chungnam,  
Korea**

박창근 2022. 8. 16

(Signature/Date)

**Mr. PARK CHANGKEUN / Manager**



## EMI / RFI POWER LINE FILTERS

LS ELECTRIC inverters, iS7 series



### RFI FILTERS

THE LS RANGE OF POWER LINE FILTERS **FEP ( Standard )** SERIES, HAVE BEEN SPECIFICALLY DESIGNED WITH HIGH FREQUENCY **LS ELECTRIC INVERTERS**. THE USE OF LS FILTERS, WITH THE INSTALLATION ADVICE OVERLEAF HELP TO ENSURE TROUBLE FREE USE ALONG SIDE SENSITIVE DEVICES AND COMPLIANCE TO CONDUCTED EMISSION AND IMMUNITY STANDARS TO EN 50081.

### CAUTION

**IN CASE OF A LEAKAGE CURRENT PROTECTIVE DEVICES IS USED ON POWER SUPPLY, IT MAY BE FAULT AT POWER-ON OR OFF.  
IN AVOID THIS CASE, THE SENSE CURRENT OF PROTECTIVE DEVICE SHOULD BE LARGER**

### RECOMMENDED INSTALLATION INSTRUCTIONS

To conform to the EMC directive, it is necessary that these instructions be followed as closely as possible. Follow the usual safety procedures when working with electrical equipment. All electrical connections to the filter, inverter and motor must be made by a qualified electrical technician.

- 1-) Check the filter rating label to ensure that the current, voltage rating and part number are correct.
- 2-) For best results the filter should be fitted as closely as possible to the incoming mains supply of the wiring enclosure, usually directly after the enclosures circuit breaker or supply switch.
- 3-) The back panel of the wiring cabinet of board should be prepared for the mounting dimensions of the filter. Care should be taken to remove any paint etc... from the mounting holes and face area of the panel to ensure the best possible earthing of the filter.
- 4-) Mount the filter securely.
- 5-) Connect the mains supply to the filter terminals marked LINE, connect any earth cables to the earth stud provided. Connect the filter terminals marked LOAD to the mains input of the inverter using short lengths of appropriate gauge cable.
- 6-) Connect the motor and fit the ferrite core ( output chokes ) as close to the inverter as possible. Armoured or screened cable should be used with the 3 phase conductors only threaded twice through the center of the ferrite core. The earth conductor should be securely earthed at both inverter and motor ends. The screen should be connected to the enclosure body via and earthed cable gland.
- 7-) Connect any control cables as instructed in the inverter instructions manual.

IT IS IMPORTANT THAT ALL LEAD LENGTHS ARE KEPT AS SHORT AS POSSIBLE AND THAT INCOMING MAINS AND OUTGOING MOTOR CABLES ARE KEPT WELL SEPARATED.

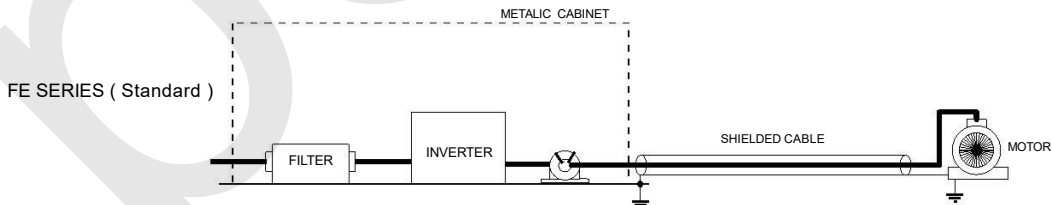

PR0062

| iS7 series / Standard Filters |       |          |         |            |                 |                  |              |         |       |      |               |
|-------------------------------|-------|----------|---------|------------|-----------------|------------------|--------------|---------|-------|------|---------------|
| INVERTER                      | POWER | CODE     | CURRENT | VOLTAGE    | LEAKAGE CURRENT | DIMENSIONS L W H | MOUNTING Y X | WEIGHT  | MOUNT | FIG. | OUTPUT CHOKES |
| THREE PHASE                   |       |          |         |            |                 |                  |              |         |       |      |               |
| SV0300iS7-2                   | 30kW  | FEP-T180 | 180A    | 220-480VAC | 0.7mA 80mA      | 332 x 170 x 120  | 115 x 155    | 8.4 Kg  | -     | B    | FS-3          |
| SV0370iS7-2                   | 37kW  | FEP-T250 | 250A    | 220-480VAC | 0.7mA 80mA      | 392 x 190 x 116  | 240 x 165    | 9.1 Kg  | -     | B    | FS-3          |
| SV0450iS7-2                   | 45kW  | FEP-T320 | 320A    | 220-480VAC | 0.7mA 80mA      | 392 x 260 x 116  | 240 x 235    | 9.8 Kg  | -     | B    | FS-4          |
| SV0550iS7-2                   | 55kW  | FEP-T320 | 320A    | 220-480VAC | 0.7mA 80mA      | 392 x 260 x 116  | 240 x 235    | 9.8 Kg  | -     | B    | FS-4          |
| SV0750iS7-2                   | 75kW  | FEP-T400 | 400A    | 220-480VAC | 0.7mA 80mA      | 392 x 260 x 116  | 240 x 235    | 10.3 Kg | -     | B    | FS-4          |

SV0300~0750iS7 EN 55011 CLASS A GROUP 2 IEC/EN 61800-3 C3

| iS7 series / Standard Filters |       |           |         |            |                 |                  |              |         |       |      |               |
|-------------------------------|-------|-----------|---------|------------|-----------------|------------------|--------------|---------|-------|------|---------------|
| INVERTER                      | POWER | CODE      | CURRENT | VOLTAGE    | LEAKAGE CURRENT | DIMENSIONS L W H | MOUNTING Y X | WEIGHT  | MOUNT | FIG. | OUTPUT CHOKES |
| THREE PHASE                   |       |           |         |            |                 |                  |              |         |       |      |               |
| SV0300iS7-4                   | 30kW  | FE-T100-2 | 100A    | 220-480VAC | 1.3mA 150mA     | 420 x 200 x 130  | 408 x 166    | 13.8 Kg | -     | A    | FS-3          |
| SV0370iS7-4                   | 37kW  | FE-T100-2 | 100A    | 220-480VAC | 1.3mA 150mA     | 420 x 200 x 130  | 408 x 166    | 13.8 Kg | -     | B    | FS-3          |
| SV0450iS7-4                   | 45kW  | FEP-T150  | 150A    | 220-480VAC | 1.3mA 150mA     | 332 x 170 x 120  | 115 x 155    | 8 Kg    | -     | B    | FS-3          |
| SV0550iS7-4                   | 55kW  | FEP-T150  | 150A    | 220-480VAC | 1.3mA 150mA     | 332 x 170 x 120  | 115 x 155    | 8 Kg    | -     | B    | FS-3          |
| SV0750iS7-4                   | 75kW  | FEP-T180  | 180A    | 220-480VAC | 1.3mA 150mA     | 332 x 170 x 120  | 115 x 155    | 8.4 Kg  | -     | B    | FS-3          |
| SV0900iS7-4                   | 90kW  | FEP-T250  | 250A    | 220-480VAC | 1.3mA 150mA     | 392 x 190 x 116  | 240 x 165    | 9.1 Kg  | -     | B    | FS-4          |
| SV1100iS7-4                   | 110kW | FEP-T400  | 400A    | 220-480VAC | 1.3mA 150mA     | 392 x 260 x 116  | 240 x 235    | 10.3 Kg | -     | B    | FS-4          |
| SV1320iS7-4                   | 132kW | FEP-T400  | 400A    | 220-480VAC | 1.3mA 150mA     | 392 x 260 x 116  | 240 x 235    | 10.3 Kg | -     | B    | FS-4          |
| SV1600iS7-4                   | 160kW | FEP-T600  | 600A    | 220-480VAC | 1.3mA 150mA     | 392 x 260 x 116  | 240 x 235    | 11 Kg   | -     | B    | FS-4          |
| SV1850iS7-4                   | 185kW | FEP-T600  | 600A    | 220-480VAC | 1.3mA 150mA     | 392 x 260 x 116  | 240 x 235    | 11 Kg   | -     | B    | FS-4          |
| SV2200iS7-4                   | 220kW | FEP-T1000 | 1000A   | 220-480VAC | 1.3mA 150mA     | 460 x 280 x 166  | 290 x 255    | 18 Kg   | -     | B    | FS-4          |
| SV2800iS7-4                   | 280kW | FEP-T1000 | 1000A   | 220-480VAC | 1.3mA 150mA     | 460 x 280 x 166  | 290 x 255    | 18 Kg   | -     | B    | FS-4          |
| SV3150iS7-4                   | 315kW | FEP-T1000 | 1000A   | 220-480VAC | 1.3mA 150mA     | 460 x 280 x 166  | 290 x 255    | 18 Kg   | -     | B    | FS-4          |
| SV3750iS7-4                   | 375kW | FEP-T1600 | 1600A   | 220-480VAC | 1.3mA 150mA     | 592 x 300 x 166  | 340 x 275    | 27 Kg   | -     | B    | FS-4          |

SV0300~2200 iS7-4 EN 55011 CLASS A GROUP 2 IEC/EN 61800-3 C3  
 SV2800~3750 iS7-4 EN 55011 CLASS A IEC/EN 61800-3 C4

FE SERIES ( Standard )

FIG.B

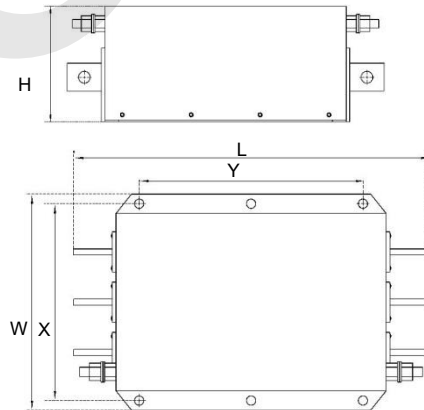
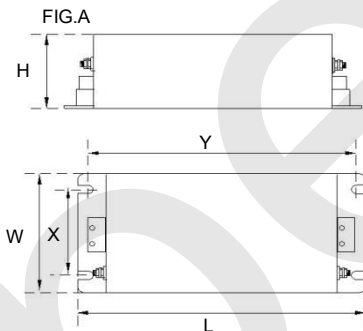

Vector Motor Control Ibérica S.L.  
 C/ Mar del Carib, 10  
 Pol. Ind. La Torre del Rector  
 08130 Santa Perpètua de Mogoda  
 (BARCELONA) ESPAÑA  
 Tel. (+34) 935 748 206  
 Fax (+34) 935 748 248  
 info@vmc.es www.vmc.es

FS SERIES ( output chokes )

| CODE   | D  | W   | H   | X        | Ø |
|--------|----|-----|-----|----------|---|
| FS - 3 | 48 | 150 | 110 | 125 x 30 | 5 |
| FS - 4 | 58 | 200 | 170 | 180 x 45 | 5 |

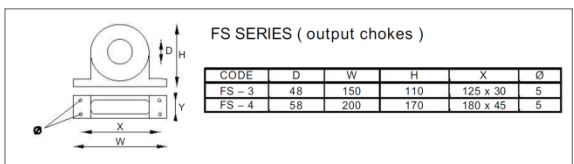

# Product Warranty

## Warranty Information

Fill in this warranty information form and keep this page for future reference or when warranty service may be required.

|                      |                      |                             |  |
|----------------------|----------------------|-----------------------------|--|
| <b>Product Name</b>  | LS ELECTRIC Inverter | <b>Date of Installation</b> |  |
| <b>Model Name</b>    | SV-iS7               | <b>Warranty Period</b>      |  |
| <b>Customer Info</b> | Name<br>(or company) |                             |  |
|                      | Address              |                             |  |
|                      | Contact Info.        |                             |  |
| <b>Retailer Info</b> | Name                 |                             |  |
|                      | Address              |                             |  |
|                      | Contact info.        |                             |  |

### Warranty Period

The product warranty covers product malfunctions, under normal operating conditions, for 12 months from the date of installation. If the date of installation is unknown, the product warranty is valid for 18 months from the date of manufacturing. Please note that the product warranty terms may vary depending on purchase or installation contracts.

### Warranty Service Information

During the product warranty period, warranty service (free of charge) is provided for product malfunctions caused under normal operating conditions. For warranty service, contact an official LS ELECTRIC agent or service center.

### Non-Warranty Service

A service fee will be incurred for malfunctions in the following cases:

- intentional abuse or negligence
- power supply problems or from other appliances being connected to the product
- acts of nature (fire, flood, earthquake, gas accidents etc.)
- modifications or repair by unauthorized persons
- missing authentic LS ELECTRIC rating plates
- expired warranty period

**Visit Our Website**

Visit us at <http://www.ls-electric.com> for detailed service information.

people's

## UL Mark



The UL mark applies to products in the United States and Canada. This mark indicates that UL has tested and evaluated the products and determined that the products satisfy the UL standards for product safety. If a product received UL certification, this means that all components inside the product had been certified for UL standards as well.

## CE mark



The CE mark indicates that the products carrying this mark comply with European safety and environmental regulations. European standards include the Machinery Directive for machine manufacturers, the Low Voltage Directive for electronics manufacturers and the EMC guidelines for safe noise control.

### Low Voltage Directive

We have confirmed that our products comply with the Low Voltage Directive (EN 61800-5-1).

### EMC Directive

The Directive defines the requirements for immunity and emissions of electrical equipment used within the European Union. The EMC product standard (EN 61800-3) covers requirements stated for drives.

## EAC mark



The EurAsian Conformity mark (EAC) indicates that the product conforms to all technical regulations of the Eurasian Customs Union assessment procedures. This means that it meets all requirements and technical regulations applicable to the product, and that it can be serviced in all service centers of the producer in the territory of all Customs Union member countries.

## Index

|  |          |  |               |
|--|----------|--|---------------|
| [ESC] key .....                                | 106      | frequency configuration.....                       | 191           |
| [Mode] key .....                               | 106      | main reference .....                               | 191           |
| [PROG / Ent] key .....                         | 106      | basic configuration diagram.....                   | 82            |
| [UP] key.....                                  | 106      | bipolar .....                                      | 73, 139       |
| <b>2nd motor operation</b> .....               | 252      | bit setting .....                                  | 189           |
| 2 <sup>nd</sup> operation mode .....           | 187      | bit (Off).....                                     | 189           |
| 2nd command source.....                        | 188      | bit (On).....                                      | 189           |
| Shared command (Main Source).....              | 188      | brake control .....                                | 272           |
| Shared command (Main Source).....              | 188      | BR Control.....                                    | 273           |
| 3-wire operation.....                          | 203      | brake engage sequence .....                        | 273, 274      |
| 4-pole standard motor .....                    | 8, 9, 11 | brake release sequence .....                       | 273, 274      |
| Acc/Dec pattern.....                           | 167      | broadcast.....                                     | 353           |
| linear pattern.....                            | 167      | built-in surge filter.....                         | 75            |
| S-curve pattern.....                           | 167      | cable  |               |
| Acc/Dec reference .....                        | 163      | shielded twisted pair .....                        | 79, 80        |
| Delta Freq .....                               | 162      | cable tie .....                                    | 293, 303, 326 |
| Max Freq.....                                  | 162      | carrier frequency.....                             | 250           |
| Acc/Dec reference frequency .....              | 162      | charge indicator .....                             | 56            |
| Ramp T Mode .....                              | 162      | charge lamp .....                                  | 56            |
| Acc/Dec stop .....                             | 170      | command .....                                      | 153           |
| Acc/Dec time .....                             | 161      | Cmd Source .....                                   | 153           |
| Acc/Dec time switch frequency .....            | 165      | configuration.....                                 | 153           |
| configuration via multi-function terminal..... | 164      | command source                                     |               |
| maximum frequency.....                         | 161      | fwd/rev command.....                               | 154           |
| operation frequency .....                      | 163      | keypad .....                                       | 153           |
| add User group                                 |          | RS-485 .....                                       | 156           |
| UserGrp SelKey.....                            | 261      | commercial power source transition .....           | 254           |
| analog frequency hold .....                    | 149      | Config (CNF) mode .....                            | 265           |
| analog hold .....                              | 149      | inverter S/W version .....                         | 265           |
| analog input                                   |          | keypad S/W version .....                           | 265           |
| V1 voltage input .....                         | 134      | keypad title update .....                          | 265           |
| analog input selection switch (SW2).....       | 145      | LCD contrast.....                                  | 265           |
| anti-hunting regulator.....                    | 286      | reset cumulative power consumption .....           | 265           |
| asymmetric ground power .....                  | 54       | connecting cables to the power terminal block..... | 60            |
| asymmetric ground structure                    |          | 0.75–22 kW (200 V/400 V).....                      | 60            |
| disabling the EMC filter.....                  | 55       | 185–220 kW (400 V).....                            | 63            |
| auto restart settings.....                     | 248      | 280–375 kW (200 V/400 V).....                      | 64            |
| auto sequence operation.....                   | 267      | 30–75 kW (200 V/400 V).....                        | 61            |
| auto torque boost .....                        | 176      | 90–160 kW (400 V) .....                            | 62            |
| auto tuning .....                              | 219      | connecting the cables .....                        | 48            |
| auto tuning .....                              | 219      | considerations for installation .....              | 16            |
| All (rotating).....                            | 221      | air pressure .....                                 | 16            |
| All (static) .....                             | 222, 224 | altitude/vibration.....                            | 16            |
| default parameter setting .....                | 220      | ambient humidity .....                             | 16            |
| auxiliary frequency .....                      | 191      | ambient temperature.....                           | 16            |
| auxiliary reference.....                       | 191      | environmental factors.....                         | 16            |
| auxiliary reference gain .....                 | 192      | storing temperature .....                          | 16            |
| final command frequency calculation.....       | 193      | contactors.....                                    | 82            |

|  |          |
|--|----------|
| cooling fan  |          |
| fan control .....  | 255      |
| cursor keys  |          |
| [UP] key .....   | 106      |
| DB resistor dimensions .....                                   | 100      |
| DB unit dimensions .....                                       | 92       |
| DB unit specifications .....                                   | 88       |
| DC braking after stop .....                                    | 181      |
| DC braking frequency .....                                     | 181      |
| DC reactor specifications .....                                | 85       |
| delta wiring .....   | 52       |
| derating .....   | 252      |
| digital source .....   | 158      |
| droop control .....  | 239      |
| dwel operation .....   | 205      |
| Acc/Dec dewel frequency .....                                  | 205      |
| acceleration dwell .....                                       | 205      |
| deceleration dwell .....                                       | 205      |
| easy start .....   | 264      |
| easy start mode .....  | 79       |
| EEP Rom Empty .....  | 257      |
| EMC filter .....   | 54       |
| asymmetric power source .....                                  | 54       |
| disabling .....  | 55       |
| energy saving operation .....                                  | 243      |
| automatic energy saving operation .....                        | 244      |
| manual energy saving operation .....                           | 243      |
| ESC key  |          |
| [ESC] key setup .....  | 156      |
| local/remote switching .....                                   | 157      |
| multi-function key .....                                       | 156      |
| remote / local operation switching .....                       | 157      |
| expanded I/O control .....                                     | 190      |
| exterior and dimensions (UL Enclosed Type 1, IP21 Type) .....  | 21       |
| SV0008-0037iS7 (200 V/400 V) .....                             | 21       |
| SV0055-0075iS7 (200 V/400 V) .....                             | 22       |
| SV0110-0150iS7 (200 V/400 V) .....                             | 23       |
| SV0185-0220iS7 (200 V/400 V) .....                             | 24       |
| SV0300-0450iS7 (400 V) .....                                   | 27       |
| SV0300-iS7 (200 V, IP00 Type) .....                            | 25       |
| SV0370-0450iS7 (200 V, IP00 Type) .....                        | 26       |
| SV0550-0750iS7 (200 V, IP00 Type) .....                        | 28       |
| SV0550-0750iS7 (400 V) .....                                   | 29       |
| SV0900-1100iS7 (400 V, IP00 Type) .....                        | 30       |
| SV1320-1600iS7 (400 V, IP00 Type) .....                        | 31       |
| SV1850-2200iS7 (400 V, IP00 Type) .....                        | 32       |
| SV2800iS7 (400 V, IP00 Type) .....                             | 33       |
| SV3150-3750iS7 (400 V, IP00 Type) .....                        | 34       |
| exterior and dimensions (UL Enclosed Type 12, IP54 Type) ..... | 35       |
| exterior and dimensions (UL Enclosed Type 12, IP54 Type)       |          |
| SV0008-0037iS7 (200 V/400 V) .....                             | 35       |
| SV0055-0075iS7 (200 V/400 V) .....                             | 36       |
| SV0110-0150iS7 (200 V/400 V) .....                             | 37       |
| SV0185-0220iS7 (200 V/400 V) .....                             | 38       |
| FE (Frame Error) .....   | 356      |
| fieldbus .....   | 133, 153 |
| communication option .....                                     | 187      |
| filter time constant .....                                     | 135      |
| filter time constant number .....                              | 189      |
| fire mode .....  | 287      |
| form A terminal (Normally Open) .....                          | 189      |
| form B terminal (Normally Closed) .....                        | 189      |
| forward or reverse run prevention .....                        | 158      |
| frame dimensions and weight .....                              | 39       |
| UL Enclosed Type 1, IP 21 Type .....                           | 39       |
| UL Enclosed Type 12, IP54 Type .....                           | 41       |
| free-run stop .....  | 182      |
| frequency hold by analog input .....                           | 149      |
| frequency jump .....   | 186      |
| frequency limit .....  | 184      |
| frequency upper and lower limit value .....                    | 184      |
| maximum/start frequency .....                                  | 184      |
| frequency reference .....                                      | 134, 179 |
| frequency reference for 0–10V input .....                      | 135      |
| frequency reference for -10–10V Input .....                    | 139      |
| frequency setting .....  | 133      |
| I1 current input .....   | 142      |
| I2 current input .....   | 145      |
| keypad .....   | 134      |
| pulse input .....  | 146      |
| RS-485 .....   | 148      |
| terminal V2/I2 .....   | 144      |
| V1 terminal .....  | 134      |
| frequency upper and lower limit value                          |          |
| Frequency lower limit value .....                              | 184      |
| Frequency upper limit value .....                              | 184      |
| ground   |          |
| class 3 ground .....   | 57       |
| ground connection .....  | 57       |
| I2 terminal .....  | 145      |
| IA (illegal data address) .....                                | 356      |
| ID (illegal data value) .....                                  | 356      |
| IF (illegal function) .....                                    | 356      |

|  |          |  |          |
|--|----------|--|----------|
| initializing accumulated electric energy count ..... | 265      | LS INV 485 Detailed Read Protocol .....                          | 353      |
| input and output specifications .....                | 7        | LS INV 485 Detailed Write Protocol .....                         | 354      |
| 200 V Class (0.75–22 kW) .....                       | 7        | LS INV 485 error code .....                                      | 356      |
| 200 V Class (30–75 kW) .....                         | 8        | FE (Frame Error) .....   | 356      |
| 400 V Class (0.75–22 kW) .....                       | 9        | IA (illegal data address) .....                                  | 356      |
| 400 V Class (185–375 kW) .....                       | 11       | ID (illegal data value) .....                                    | 356      |
| 400 V Class (30–160 kW) .....                        | 10       | IF (illegal function) .....                                      | 356      |
| input phase open                                     |          | WM (write mode error) .....                                      | 356      |
| input open-phase protection .....                    | 326      | LS INV 485 protocol .....  | 351      |
| input power frequency .....                          | 256      | LSINV 485 .....  | 344      |
| input power voltage .....                            | 257      | macro selection .....  | 263      |
| input terminal .....                                 | 189      | draw .....   | 263      |
| bit setting .....                                    | 189      | traverse .....   | 263      |
| form A (NO) or B (NC) terminal configuration .....   | 189      | magnetic contactor .....   | 56       |
| NO/NC configuration .....                            | 189      | manual torque boost .....  | 175      |
| input terminal contact                               |          | master .....   | 343      |
| form A contact .....                                 | 327      | maximum allowed prospective short-circuit currentiii,<br>11, 379 |          |
| form B contact .....                                 | 327      | MMC function .....   | 275      |
| installation .....                                   | 16       | Modbus-RTU .....   | 344      |
| basic configuration diagram .....                    | 82       | momentary power interruption .....                               | 247, 248 |
| location .....                                       | 17       | monitor function .....   | 291      |
| installation conditions .....                        | 16       | monitoring   |          |
| jog operation .....                                  | 196      | monitor registration protocol details .....                      | 355      |
| Jog operation  |          | motor features   |          |
| 1-FWD jog .....                                      | 196      | capacity .....   | 207      |
| 2-forward/reverse jog .....                          | 197      | efficiency .....   | 208      |
| Jog frequency .....                                  | 196      | no-load current .....  | 208      |
| keypad input .....                                   | 198      | output voltage setting .....                                     | 178      |
| jump frequency .....                                 | 186      | thermal protection(ETH)  |          |
| keypad   |          | E-Thermal .....  | 316      |
| [ESC] key .....                                      | 106      | motor protection .....   | 316      |
| [Mode] key .....                                     | 106      | motor thermal protection(ETH) .....                              | 316      |
| [PROG / Ent] key .....                               | 106      | multi-function input terminal                                    |          |
| LCD brightness/contrast .....                        | 265      | multi-function input terminal Off filter .....                   | 189      |
| navigating between groups .....                      | 110      | multi-function input terminal On filter .....                    | 189      |
| SW version .....                                     | 265      | multi-function input terminal control .....                      | 189      |
| keypad title update .....                            | 265      | multi-function output on/off control .....                       | 275      |
| kinetic energy buffering .....                       | 240      | multi-step frequency .....                                       | 150      |
| lift-type load .....                                 | 167, 175 | setting .....  | 150      |
| linear pattern .....                                 | 167      | Speed-L/Speed-M/Speed-H .....                                    | 151      |
| linear V/F pattern operation .....                   | 171      | noise .....  | 54, 137  |
| base frequency .....                                 | 171      | normal PWM .....   | 251      |
| start frequency .....                                | 171      | number of motor poles .....                                      | 207      |
| local operation .....                                | 157      | operation noise .....  | 250      |
| [ESC] key .....                                      | 157      | carrier frequency .....  | 250      |
| local/remote mode switching .....                    | 156      | frequency jump .....   | 186      |
| remote peration .....                                | 157      | operation time monitor .....                                     | 314      |
| low leakage PWM .....                                | 251      |  |          |



|  |          |                                       |     |
|--|----------|---------------------------------------|-----|
| overload rate.....                               | 252      | regenerated energy.....               | 183 |
| P/I gain.....                                    | 248      | remote operation.....                 | 157 |
| parameter  |          | [ESC] key.....                        | 157 |
| display changed parameter.....                   | 261      | local operation.....                  | 157 |
| hide parameter mode.....                         | 259      | local/remote mode switching.....      | 156 |
| parameter initialization.....                    | 258      | resistor brakes.....                  | 82  |
| parameter lock.....                              | 260      | resonance frequency                   |     |
| password.....                                    | 259, 260 | carrier frequency.....                | 250 |
| parameter initialization.....                    | 258      | restarting after a trip               |     |
| parameter  |          | reset and restart.....                | 160 |
| read/write/save.....                             | 257      | retry number.....                     | 160 |
| part names.....                                  | 4        | ripple.....                           | 137 |
| parts illustrated.....                           | 4        | RS-232.....                           | 343 |
| password.....                                    | 259, 260 | communication.....                    | 343 |
| PID  |          | RS-485                                |     |
| flow control.....                                | 210      | communication.....                    | 343 |
| pressure control.....                            | 210      | converter.....                        | 343 |
| speed control.....                               | 210      | integrated communication.....         | 148 |
| temperature control.....                         | 210      | signal terminal.....                  | 148 |
| PID control.....                                 | 210      | run prevention                        |     |
| PID basic operation.....                         | 210      | Fwd.....                              | 159 |
| PID openloop.....                                | 219      | Rev.....                              | 159 |
| PID operation sleep mode.....                    | 218      | SW version.....                       | 265 |
| PID operation switching.....                     | 219      | inverter.....                         | 265 |
| PID pre operation.....                           | 217      | keypad.....                           | 265 |
| post-installation checklist.....                 | 78       | safe operation mode.....              | 204 |
| Power-on Run.....                                | 159      | safety information.....               | ii  |
| preparing the installation.....                  | 1        | S-curve pattern.....                  | 167 |
| product identification.....                      | 1        | actual Acc/Dec time.....              | 169 |
| product specification details.....               | 12       | sensorless-1 vector control.....      | 225 |
| control.....                                     | 12       | sensorless-2 vector control.....      | 227 |
| operation.....                                   | 12       | slave.....                            | 343 |
| protection function.....                         | 14       | slip.....                             | 207 |
| structure and operating environment control..... | 14       | slip compensation operation.....      | 207 |
| protocol   |          | speed search configuration.....       | 246 |
| LS INV 485 protocol.....                         | 351      | speed search operation.....           | 245 |
| PWM.....   | 250      | Flying Start-1.....                   | 245 |
| frequency modulation.....                        | 250      | Flying Start-2.....                   | 246 |
| quantizing.....                                  | 137      | options.....                          | 246 |
| noise.....                                       | 137      | P/I gain.....                         | 248 |
| R/S/T terminal.....                              | 56       | speed unit selection (Hz or Rpm)..... | 150 |
| rating   |          | speed/torque control switching.....   | 239 |
| rated motor current.....                         | 207      | square reduction                      |     |
| rated motor voltage.....                         | 219      | square reduction load.....            | 172 |
| rated slip frequency.....                        | 209      | V/F pattern operation.....            | 172 |
| rated slip speed.....                            | 207      | stall                                 |     |
| rating plate.....                                | 1        | bit On/Off.....                       | 320 |
| reactor.....                                     | 82       | stall prevention.....                 | 320 |

|  |          |  |
|--|----------|--|
| start at power-on                            |          |  |
| Power-on Run .....                           | 159      |  |
| start mode .....                             | 179      |  |
| acceleration start .....                     | 179      |  |
| start after DC braking .....                 | 179      |  |
| stop mode .....                              | 180      |  |
| deceleration stop .....                      | 180      |  |
| free run stop .....                          | 182      |  |
| power braking .....                          | 183      |  |
| stop after DC braking .....                  | 181      |  |
| surge killer .....                           | 56       |  |
| technical specifications .....               | 7        |  |
| terminal                                     |          |  |
| form A terminal .....                        | 189      |  |
| form B terminal .....                        | 189      |  |
| terminal wiring diagram .....                | 58       |  |
| test run .....                               | 79       |  |
| time scale setting .....                     | 162      |  |
| 0.01sec .....                                | 162      |  |
| 0.1sec .....                                 | 162      |  |
| 1sec .....                                   | 162      |  |
| timer settings .....                         | 266      |  |
| torque .....                                 | 56       |  |
| torque boost .....                           | 175      |  |
| auto torque boost .....                      | 176      |  |
| manual torque boost .....                    | 175      |  |
| overexcitation .....                         | 176, 178 |  |
| torque control .....                         | 237      |  |
| traverse operation .....                     | 271      |  |
| trip   |          |  |
| erasing trip history .....                   | 265      |  |
| U&M mode .....                               | 262      |  |
| U/V/W terminal .....                         | 56       |  |
| Unipolar .....                               | 73       |  |
| up-down operation .....                      | 199      |  |
| User & Macro mode .....                      | 110      |  |
| User group .....                             | 261      |  |
| delete parameters .....                      | 262      |  |
| parameter registration .....                 | 262      |  |
| user V/F pattern operation .....             | 173      |  |
| V/F control .....                            | 171      |  |
| linear V/F pattern operation .....           | 171      |  |
| square reduction V/F pattern operation ..... | 172      |  |
| user V/F pattern operation .....             | 173      |  |
| V/F operation using speed sensor .....       | 224      |  |
| V2 terminal .....                            | 144      |  |
| variable torque load .....                   | 172      |  |
| vector control mode operation .....          | 232      |  |
| voltage drop .....                           | 56       |  |
| wiring                                       |          |  |
| copper cable .....                           | 56       |  |
| wiring length .....                          | 56       |  |
| WM (write mode error) .....                  | 356      |  |